

Use & Care Guide

Model: 90109

Kenmore®

Liquid Propane Gas Grill

P/N 19000343A0 (1110)
Sears Canada Inc.
Toronto, ON., M5B 2C3
www.sears.ca



TM

Table of Contents

Warranty-----	2
Safety Precautions-----	2~4
Package Content List-----	5~6
Hardware Contents-----	7
Preparation-----	7
Parts Diagram -----	8
Parts List-----	9
Assembly Instructions-----	10-15
Lighting Instructions-----	16~17
Cleaning and Maintenance-----	18
Troubleshooting-----	19
Cooking Instruction-----	20
Cooking Chart-----	21

Kenmore Grill Warranty

One-Year Full Warranty on Kenmore Grill

If this grill fails due to a defecting material or workmanship within one year from the date of purchase, call 1-800-913-8999 (English) or 1-800-648-5864 (French) to arrange for free repair (or replacement if repair proves impossible).

Five-Year Limited Warranty on Stainless Steel Burners

For five years from the date of purchase, any stainless steel burner that rusts through will be replaced free of charge. After the first year from the date of purchase, you pay for labor if you wish to have it installed.

All warranty coverage excludes ignitor batteries and grill part paint loss, discoloration or rusting, which are either expendable parts that can wear out from normal use within the warranty period, or are conditions that can be the result of normal use, accident or improper maintenance.

All warranty coverage is void if this grill is ever used for commercial or rental purposes.

All warranty coverage applies only if this grill is used in the Canada.

Sears Canada Inc.
Toronto, ON., M5B 2C3

Precautions



WARNING

Failure to comply with these instructions could result in a fire or explosion that could cause serious bodily injury, death, or property damage.



WARNING

Your grill will get very hot. Never lean over the cooking area while using your grill. Do not touch cooking surfaces, grill housing, lid or any other grill parts while the grill is in operation, or until the gas grill has cooled down after use.
Failure to comply with these instructions may result in serious bodily injury.



WARNING

- 1. Do not store or use gasoline or other flammable liquids or vapors in the vicinity of this or any other appliance.**
- 2. An LP cylinder not connected for use shall not be stored in the vicinity of this or any other appliance.**



DANGER

If you smell gas:

- 1. Shut off gas to the appliance.**
- 2. Extinguish any open flame.**
- 3. Open lid.**
- 4. If odor continues, keep away from the appliance and immediately call your gas supplier or your fire department.**

Grill Installation Codes

The installation must conform with local codes or, in the absence of local codes, with either the national fuel gas code, ANSI Z 223.1/NFPA S4, Natural gas and propane installation code, CSA B149.1, or propane storage and handling code, B149.2, or the standard for Recreational vehicles, ANSI A 119.2, and CSA Z240 RV series recreational vehicle code, as applicable. LP gas grill models are designed for use with a standard 20 lb. Liquid Propane Gas tank, not included with grill. Never connect your gas grill to an LP gas tank that exceeds this capacity.

Precautions

A tank of approximately 12 inches in diameter by 18-1/2 inches high is the maximum size LP gas tank to use.

You must use an OPD gas tank which offers an Overfill Prevention Device.

This safety feature prevents the tank from being overfilled which can cause malfunction of the LP gas tank, pressure regulator and/or grill.

The LP gas tank must be constructed and marked in accordance with specifications of the U.S. Dept. of Transportation (DOT). In Canada, the LP gas tank must meet the National Standard of Canada ,CAN/CSA-B339 , Cylinders , spheres and Tubes for Transportation of Dangerous Goods and Commission .

1. The LP gas tank must have a shutoff valve, terminating in an LP gas supply tank valve outlet, that is compatible with a Type 1 tank connection device. The LP gas tank must also have a safety relief device that has a direct connection with the vapor space of the tank.
2. The tank supply system must be arranged for vapor withdraw.
3. The LP gas tank used must have a collar to protect the tank valve.

Proper Placement and Clearance of Grill

Never use your gas grill in a garage, porch, shed, breezeway or any other enclosed area. Your gas grill is to be used **outdoors only**, at least 24 inches from the back and side of any combustible surface. Your gas grill should not be used under overhead combustible construction . Do not obstruct the flow of ventilation air around the gas grill housing.

- Do not install this outdoor gas grill in or on recreational vehicles or boats
- Keep outdoor gas grill area clear and free from combustible materials, gasoline and other flammable vapors and liquids
- Do not obstruct the flow of combustion and ventilation air. Check for this each time prior to using grill.
- **Never** connect an unregulated LP gas tank to your gas grill. The gas pressure regulator assembly supplied with your gas grill is adjusted to have an outlet pressure of 11" water column (W.C.) for connection to an LP gas tank.
- Only use the pressure regulator and the hose assembly supplied with your gas grill. Replacement pressure regulators and hose assemblies must be those specified in this manual.

- Have your LP gas tank filled by a reputable propane gas dealer and visually inspected and re-qualified at each filling.
- Do not store a spare LP gas tank under or near this appliance.
- Never fill the tank beyond 80 percent full . If this information is not followed exactly a fire causing death or serious injury may occur.
- Always keep LP gas tanks in an upright position.
- Do not store or use gasoline or other flammable vapors and liquids in the vicinity of this gas grill.
- Do not subject the LP gas tank to excessive heat.
- Never store an LP gas tank indoors. If you store your gas grill in the garage or other indoor location, **always** disconnect the LP gas tank first and store it safely outside.



Always keep the LP cylinder at 90° (upright) orientation to provide vapor withdraw.

- Place dust cap on cylinder valve outlet whenever the cylinder is not in use. Only install the type of dust cap on the cylinder valve outlet that is provided with the cylinder valve. Other types of caps or plugs may result in leakage of propane.
- LP gas tanks must be stored outdoors in a well-ventilated area and out of reach of children. Disconnected LP gas tanks must not be stored in a building, garage or any other enclosed area.
- When your gas grill is not in use the gas must be turned off at the LP gas tank.
- The pressure regulator and hose assembly must be inspected before each use of the grill. If there is excessive abrasion or wear or if the hose is cut, it must be replaced prior to the grill being used again.
- Keep the gas pressure regulator hose away from hot grill surfaces and dripping grease. Avoid unnecessary twisting of hose. Visually inspect the hose prior to each use for cuts, cracks, excessive wear or other damage. If the hose appears damaged do not use the gas grill. Call 1-800-913-8999 (English) or 1-800-648-5864 (French) for a replacement hose.
- **Never** light your gas grill with the lid closed or before checking to ensure the burner tubes are fully seated over the gas valve orifices.
- **Never** allow children to operate your grill.



WARNING

A strong gas smell, or the hissing sound of gas indicates a serious problem with your gas grill or the LP gas tank. Failure to immediately follow the steps listed below could result in a fire or explosion that could cause serious bodily injury, death, or property damage.

- Shut off gas supply to the gas grill.
- Turn the control knobs to OFF position.
- Put out any flame with a proper fire extinguisher.
- Open Grill Lid.
- Get away from the LP gas tank.
- Do not try to fix the problem yourself.
- If odor continues or you have a fire you can not extinguish, call your fire department. Do not call near the LP gas tank because your telephone is a form of electrical device and could create a spark resulting in fire and/or explosion.

NOTE: The normal flow of gas through the pressure regulator and hose assembly can create a humming noise. A low volume of noise is perfectly normal and will not interfere with operation of the grill. If humming noise is loud and excessive you may need to purge air from the gas line or reset the pressure regulator excess gas flow device. This purging procedure should be done every time a new LP gas tank is connected to your grill. For help with this procedure refer to page 16, Item 4 of "If Grill Still Fails To Light", or call the Grill Information Center at 1-800-913-8999 (English) or 1-800-648-5864 (French).

CAUTION: Beware of Flash-Back

CAUTION: Spiders and small insects occasionally spin webs or make nests in the grill burner tubes during transit and warehousing. These webs can lead to gas flow obstruction which could result in a fire in and around burner tubes. This type of fire is known as "FLASH-BACK" and can cause serious damage to your grill and create an unsafe operating condition for the user.

Although an obstructed burner tube is not the only cause of "FLASH-BACK", it is the most common cause.

To reduce the chance of "FLASH-BACK", you must clean the burner tubes before assembling your grill, and at least once a month in late summer or early fall when spiders are most active. Also perform this burner tube cleaning procedure if your grill has not been used for an extended period of time.





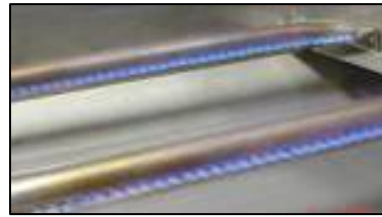

See Cleaning Burner Tubes and Ports on page # 18.

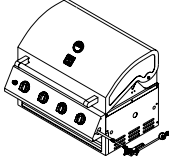
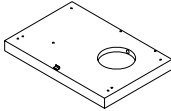

Burner Flame Check



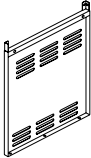
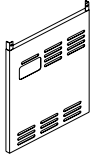
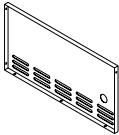

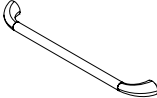
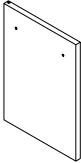
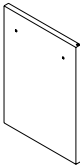
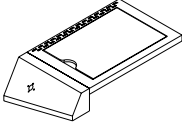
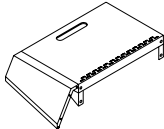
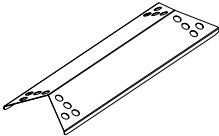
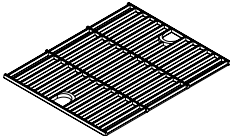
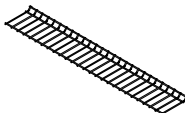

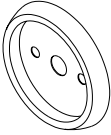
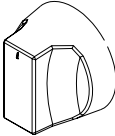

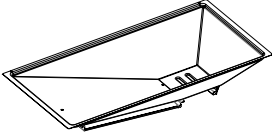
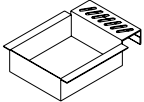
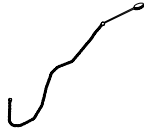
Visually check the burner flames prior to each use. The flames should look like picture, if they do not, refer to the cleaning burner tubes and ports, see page 18 of this manual.

PACKAGE CONTENTS LIST

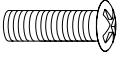
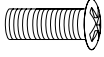
<p>A. Firebox-----1pc.</p> 	<p>B. Bottom panel----1pc.</p> 	<p>C. Tank Tray Bolt---1pc.</p> 
<p>D. Swivel Caster with Brake---1pc.</p> 	<p>E. Swivel Caster-----1pc.</p> 	<p>F. Caster-----2pcs.</p> 
<p>G. Side Panel, Left----1pc.</p> 	<p>H. Side Panel, Right----1pc.</p> 	<p>I. Back panel----1pc.</p> 
<p>J. Gas Tank Barrier Bar---1pc.</p> 	<p>K. Door handle----2pcs.</p> 	<p>L. Door, Left-----1pc.</p> 
<p>M. Door Right-----1pc.</p> 	<p>N. Side Burner bowl assembly frame with Side burner control panel----1pc.</p> 	<p>O. Left side shelf with side shelf front panel-----1pc.</p> 
<p>P. Heat Diffuser-----4pcs.</p> 	<p>R. Cooking Grid---2pcs.</p> 	<p>S. Warming Racket-----1pcs.</p> 

<p>T. Bezel-----1 pc</p> 	<p>U.. Control Knob-----1 pc</p> 	<p>V.1.5 Volt "AA" Size Alkaline Battery-----1pc.</p> 
<p>W. Grease Tray -----1pc.</p> 	<p>X. Grease Cup-----1pc</p> 	<p>Y. Manual Lighting Stick-----1pc.</p> 

Hardware Pack Contents

Item	Description	Specification	Quantity
AA	Phillips Head Screw 	1/4 x 15mm	16 pcs
BB	Phillips Head Screw 	1/4 x 10mm	14 pcs
CC	Phillips Head Screw 	5/32 x 8mm	15pcs
DD	Flat Head Screw 	5/32 x 8mm	8 pcs
EE	Flat Washer 	1/4	4pcs
FF	Lock Washer 	1/4	26pcs
GG	Lock Washer 	5/32	11 pcs
HH	Hex Wrench 	5/64	1pc

Preparation

Before beginning assembly, make sure all parts are present. Compare parts with package contents list and diagram above. If any part is missing or damaged, do not attempt to assemble the product. Contact customer service for replacement parts.

- Tools required for Assembly.

Phillips Screwdriver (not included) and Wrench (not included).

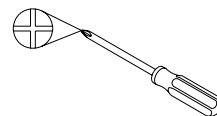

Phillips Screwdriver

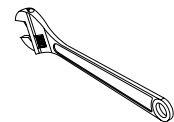

Wrench

- Note: The left and right sides of the grill are on your left and right as you face the front of the grill.

Model 90109 Parts diagram

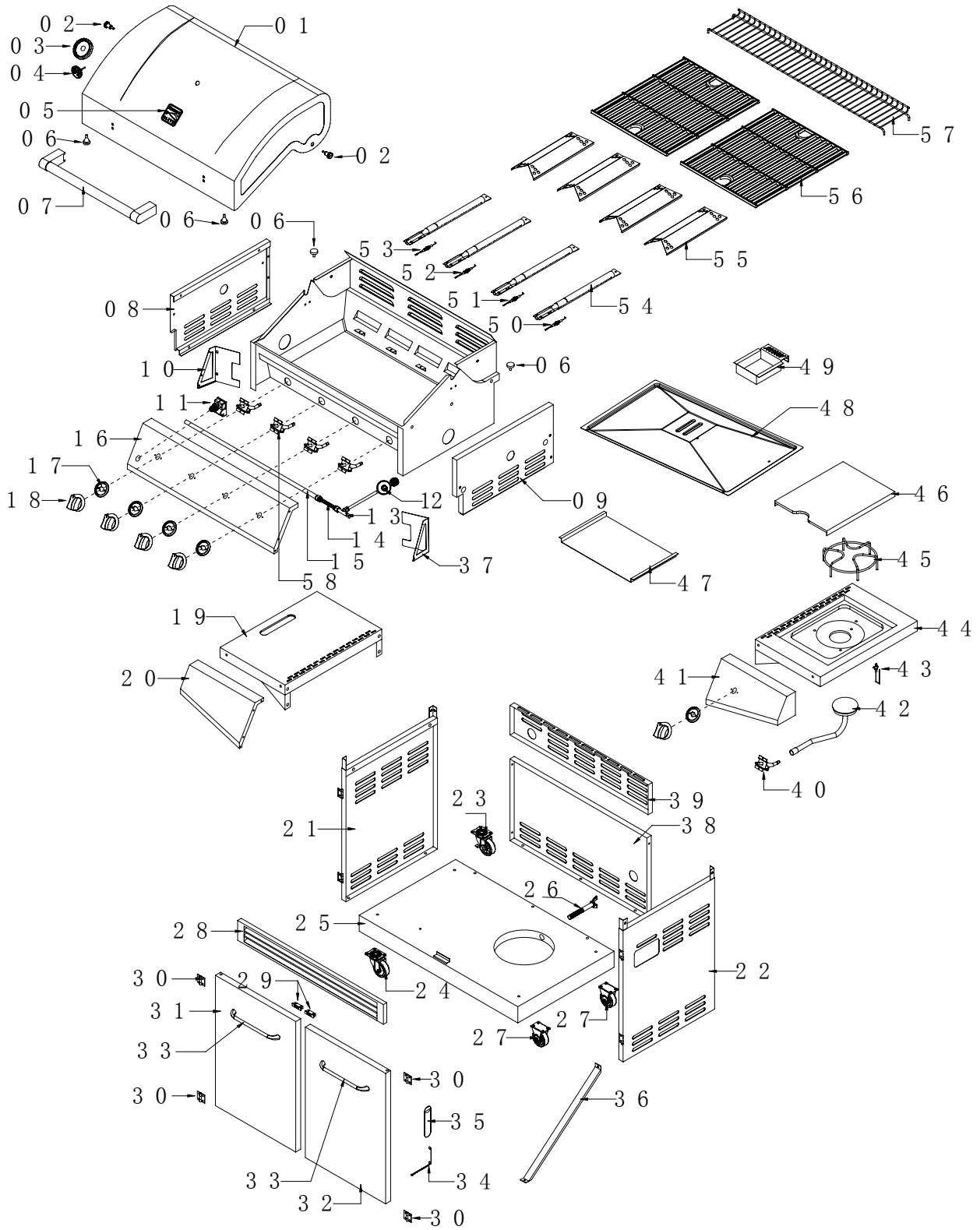

Model 90109 Parts List

KEY#	PARTS	DESCRIPTION	QUANTITY	KEY#	PARTS	DESCRIPTION	QUANTITY
1	0773-001	Main Lid	1	30	0773-030	Door Hinge	4
2	0773-002	Main Lid Screw	2	31	0773-031	Front Door, Left	1
3	0773-003	Temperature Gauge Housing	1	32	0773-032	Front Door, Right	1
4	0773-004	Temperature Gauge	1	33	0773-033	Door Handle	2
5	0773-005	Logo	1	34	0773-034	Lighting Rod	1
6	0773-006	Hood Buffer	4	35	0773-035	Lighting Rod Cover	1
7	0773-007	Main Lid Handle	1	36	0773-036	Gas Tank Barrier Bar	1
8	0773-008	Flange, Left	1	37	0773-037	control panel support bracket, Right	1
9	0773-009	Flange, Right	1	38	0773-038	Back Panel	1
10	0773-010	control panel support bracket, left	1	39	0773-039	Back Panel, Top	1
11	0773-011	Pulse Igniter Module	1	40	0773-040	Side Burner Gas Valve	1
12	0773-012	Regulator, LP	1	41	0773-041	Side Burner Front Panel	1
13	0773-013	Side Manifold	1	42	0773-042	Side Burner Pipe Assembly	1
14	0773-014	Side Burner Flex Gas Line	1	43	0773-043	Side Burner Igniter Wire	1
15	0773-015	Main Manifold	1	44	0773-044	Side Burner Bowl Assembly	1
16	0773-016	Main Control Panel	1	45	0773-045	Side Burner Cooking Grate	1
17	0773-017	Bezel	5	46	0773-046	Side Burner Lid	1
18	0773-018	Control Knob	5	47	0773-047	Gas Tank Heat Shield	1
19	0773-019	Side Shelf, Left	1	48	0773-048	Grease Slide Panel	1
20	0773-020	Side Shelf Front Panel, Left	1	49	0773-049	Grease Box	1
21	0773-021	Side Panel, Left	1	50	0773-050	Main Burner Igniter Wire A	1
22	0773-022	Side Panel, Right	1	51	0773-051	Main Burner Igniter Wire B	1
23	0773-023	Swivel Caster with Brake	1	52	0773-052	Main Burner Igniter Wire C	1
24	0773-024	Swivel Caster	1	53	0773-053	Main Burner Igniter Wire D	1
25	0773-025	Bottom Panel, LP	1	54	0773-054	Main Burner	4
26	0773-026	Tank Tray Bolt	1	55	0773-055	Heat Diffuser	4
27	0773-027	Caster	2	56	0773-056	Cooking Grid with Hole	2
28	0773-028	Cart Frame, Front	1	57	0773-057	Warming Rack	1
29	0773-029	Door Magnet	2	58	0773-058	Main Gas Valve	4

If you are missing hardware or have damaged parts after unpacking grill, call 1-800-913-8999 (English) or 1-800-648-5864 (French) for replacements.

To order replacement parts after using grill, call: 1-800-913-8999 (English) or 1-800-648-5864 (French).

To make sure you obtain the correct replacement parts for your Kenmore gas grill, please refer to the part numbers on this page.

Important: Use only parts listed above. When ordering parts, providing the following information:

1. Model #
2. Serial # (found inside the front panel of your grill)
3. Part Number (see PART# in chart)
4. Part Description
5. Quantity of parts needed

Assembly Instructions

CAUTION: While it is possible for one person to assemble this grill, obtain assistance from another person when handling some of the larger, heavier pieces.

Note: Be sure to slide grease tray out of back of grill head and remove all packaging from tray.

1. Use the parts list to check that all parts have been included.

2. Inspect the grill for damage as you assemble it. Do not assemble or operate the grill if it appears damaged. If there are damaged or missing parts when you unpack the shipping box, or you have questions during the assembly process, call:

**For Assembly Questions, call 1-800-648-5864
8AM – 5 PM PST, Monday through Friday.**

1. Assembling Grill Cart

(a) Attach four casters to bottom panel (B) using (16) 1/4 x15mm Phillips head screws (AA), (16) 1/4 lock washers (FF). Note: (D) is swivel caster with brake, (E) is swivel caster, (F) are straight casters. (Fig.1)

Hint: For ease of caster assembly, turn bottom panel upside down.

(b) Attach left & right side panels (G & H) to bottom panel (B) using (4) 5/32 x 8mm Phillips head screws (CC) with (4) 5/32 lock washers (GG). (Fig.2)

(c) Attach back panel (I) to bottom panel (B) using (3) 5/32 x 8mm Phillips head screws (CC) with (3) 5/32 lock washers (GG). Attach back panel (I) to side panel (G&H) using (4) 1/4 x 10mm Phillips head screws (BB) with (4) 1/4 lock washers (FF) . (Fig.3)

(d) Attach gas tank barrier bar (J) to back panel (I) using (1) 5/32 x 8mm Phillips head screw (CC) and (1) 5/32 lock washer (GG) from the back panel side. Attach bar to bottom panel using same size screw and lock washer. (Fig. 4)

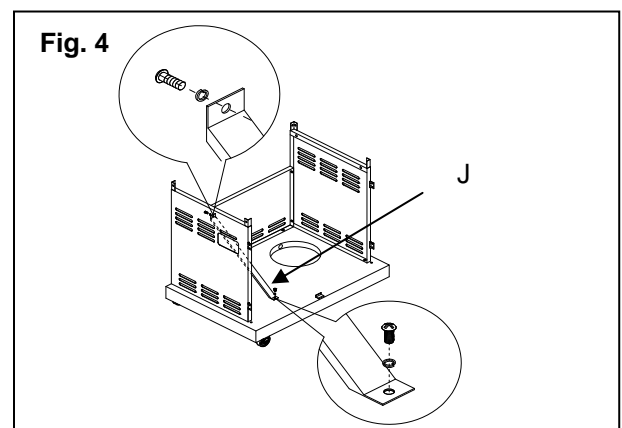
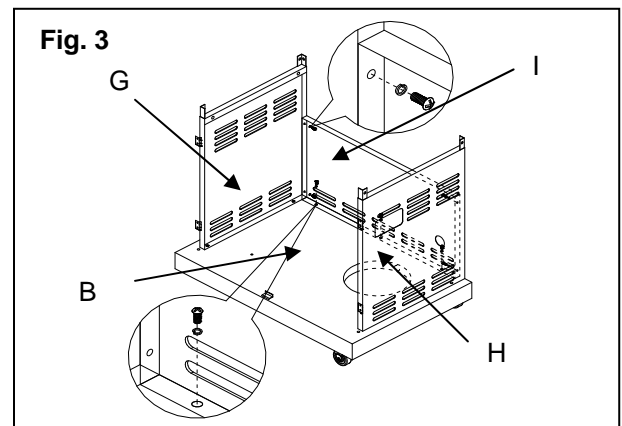
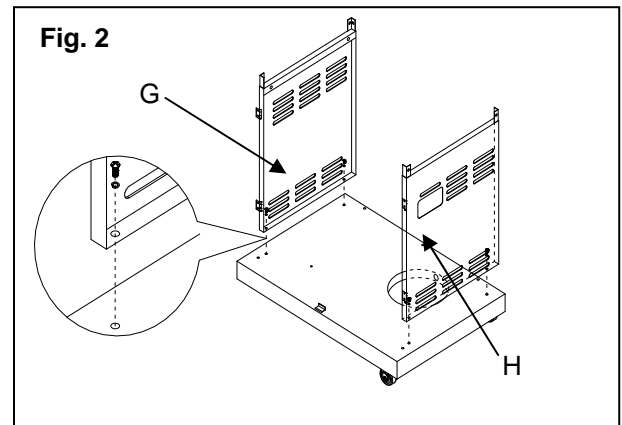
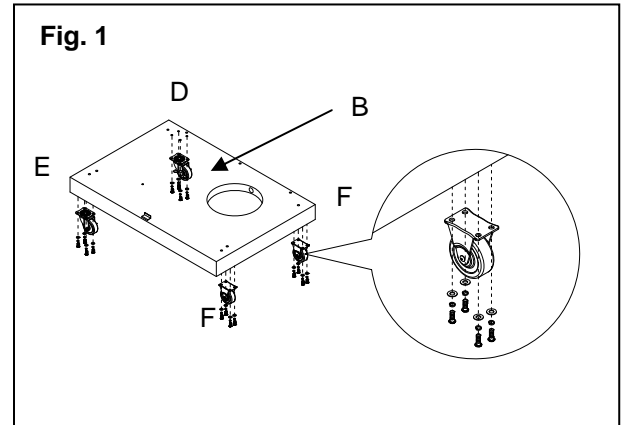

(e) Attach door handle (K) to left door (L) using (2) 5/32 x 8mm Phillips head screws (CC) and (2) 5/32 lock washers (GG). Repeat to assemble the other door handle to right door (M). (Fig.5)

(f) Attach two doors (L & M) to side panels (G & H) using (8) 5/32 x 8mm flat head screws (DD). (Fig. 6)

2. Firebox Assembly

(a) Be sure grill cart doors are closed to stabilize cart. Remove grill head (A) from carton. Place onto cart from above as shown in (Fig. 7)

CAUTION: Grill head is heavy. To avoid injury, obtain the help of an assistant for this step. Also, make sure doors remain closed when placing grill head onto cart. DO NOT open doors until grill head is securely mounted to cart.

(b) Attach grill head (A) to left and right side panels (G & H) using (6) 1/4 x 10mm Phillips head screws (BB) and (6) lock washers (FF). (Fig. 8)

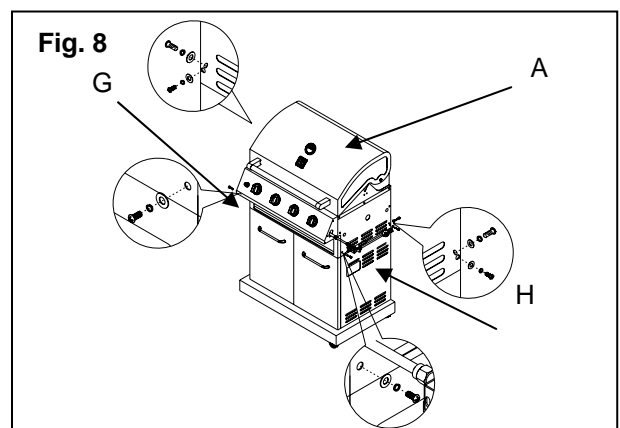
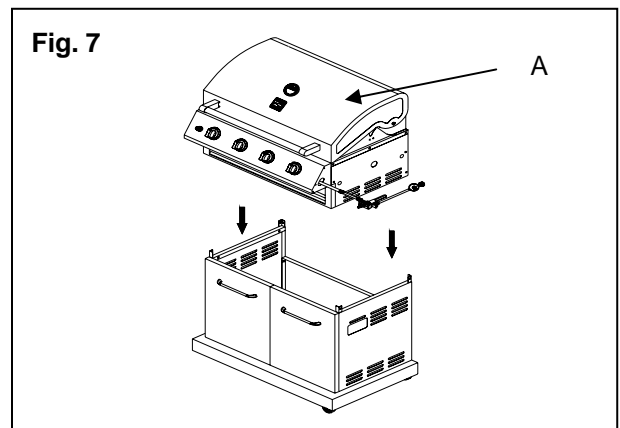
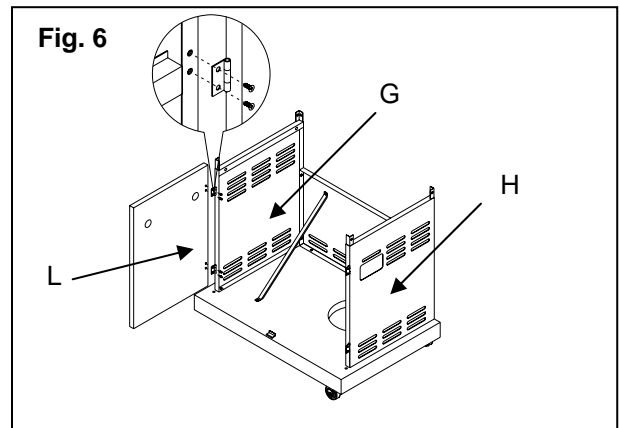
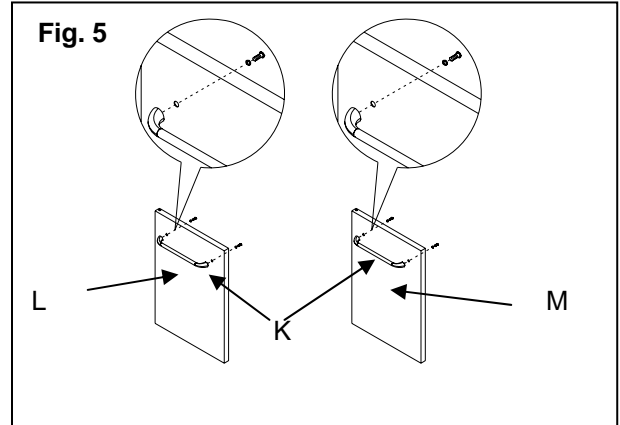

3. Side Burner & Side Shelf Assembly

(a) Loosen (2) preinstalled 1/4 x 10mm Phillips head screws from right side of grill head (A) as shown. Do not screw out fully; leave 1/4 extended for shelf assembly. (Fig. 9)

(b) Through side burner shelf keyholes, hang side burner shelf (N) on two loosened screws. (Fig. 10)

(c) Using (2) 1/4 x 10mm Phillips head screws (BB) and (2) 1/4 flat washers (EE), attach side burner shelf (N) to grill head from inside the firebox. Insert (1) 5/32 x 8 mm Phillips head screws (CC) and (1) 5/32 lock washers (GG) to attach the side burner shelf front panel to the control panel (Fig 11). Fully tighten the two loosened screws to secure shelf to firebox.

(d) Repeat steps (a) through (c) to install side shelf.

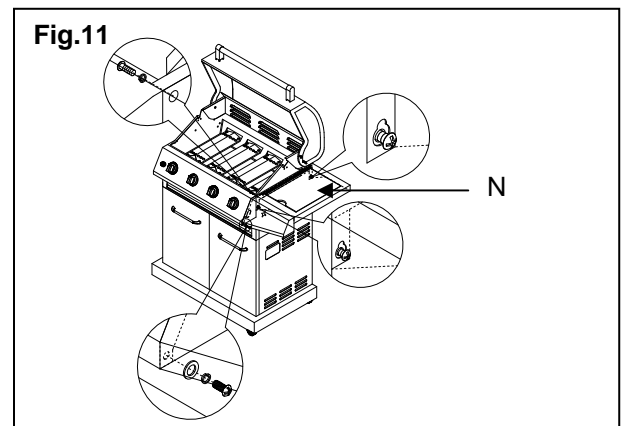
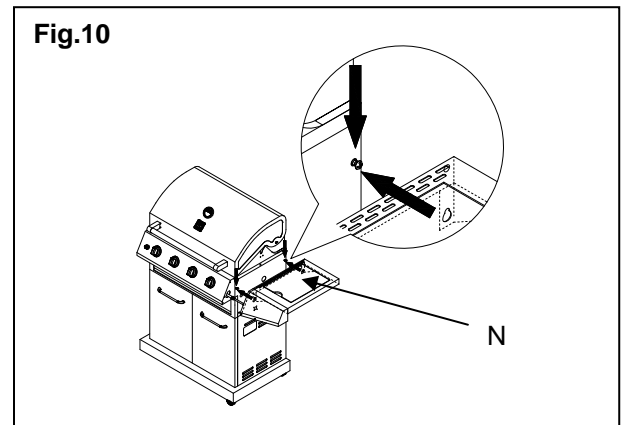
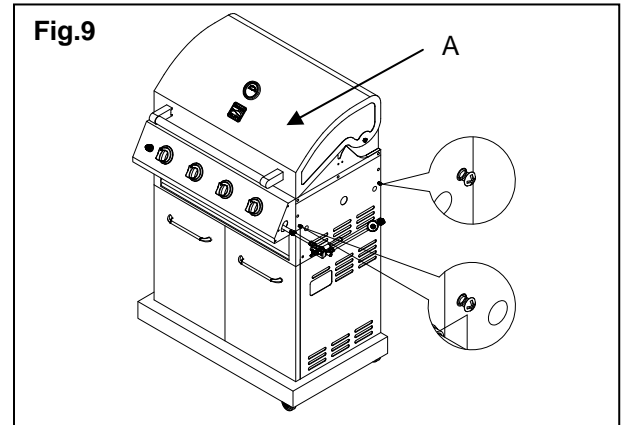

4. Side Burner Valve Assembly

(a) Remove side burner grate from side burner shelf and set aside. Remove the two Phillips head screws attaching side burner (N) to shelf to make room to install side burner valve. See (Fig.12)

(b) Remove two screws from side burner control valve face. Insert side burner valve control stem through hole in side burner control panel . Place side burner control knob bezel (T) over side burner valve control stem. Secure bezel to control panel and valve with 2 screws removed above. (Fig . 13A1).

(c) Insert side burner tube over side burner valve orifice (Fig. 13B1). Use the two previously removed side burner screws to reattach side burner to side burner shelf.

(d) Push control knob (U) onto valve control stem, and tighten use hex wrench. (Fig.14)

(e) Plug ignition wire into igniter wire hanging from electrode on underside of burner (Fig.15).

(f) Replace the side burner grate into the side burner shelf.

Fig. 12

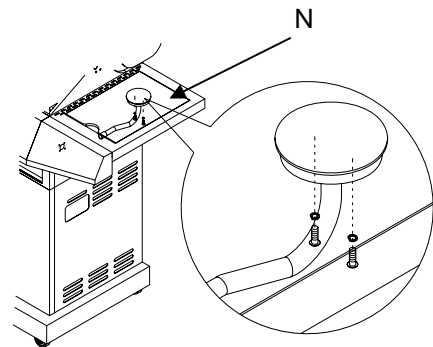

Fig. 13

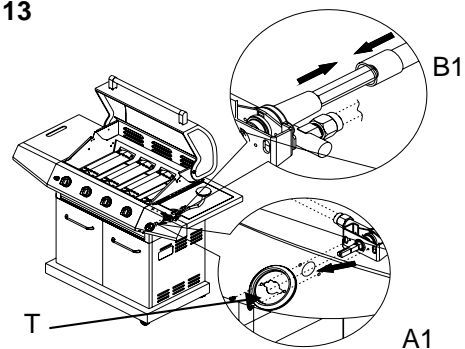

Fig. 14

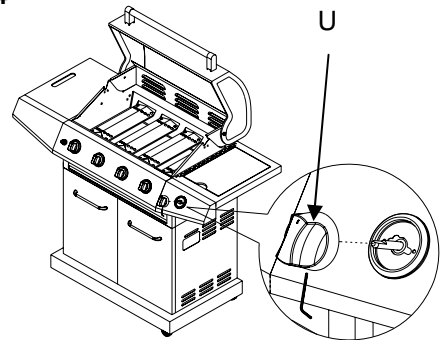
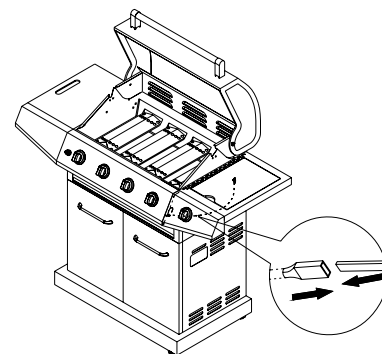

Fig. 15



5. Grease Cup Assembly

From the back, pull out grease tray (W), remove any packaging materials from it, then insert grease cup (X) into grease tray (W) as shown in (Fig.16). Push grease tray back into grill.

6. Installing Cooking Components

(a) Place heat diffusers over burners as shown. Diffuser ends insert into channels on front and back of firebox. (Fig. 17)

(b) Evenly space cooking grates (R) on the ledge above heat diffusers. (Fig.17)

To obtain sear marks in cooked meat, be sure to insert grates so that side with four corner feet faces down.

(c) Insert legs of warming rack (S) into the holes in the top of firebox side panels. (Fig.17)

7. Battery Assembly

(a) Unscrew the ignition battery cap. (Found at far left of control panel)

(b) Install battery (V) into ignition box with positive terminal facing outward.

(c) Replace the ignition battery cap after the battery has been installed. (Fig. 18)

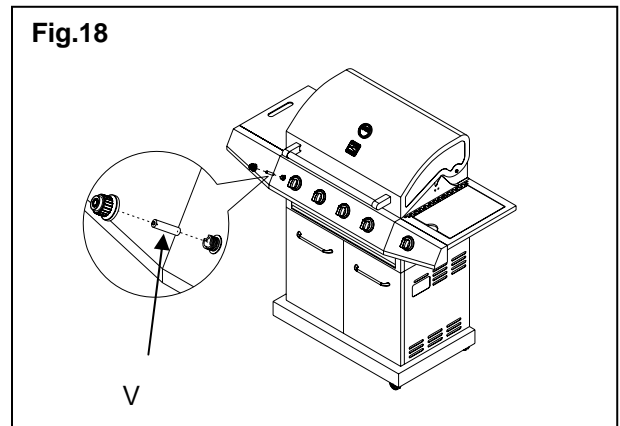
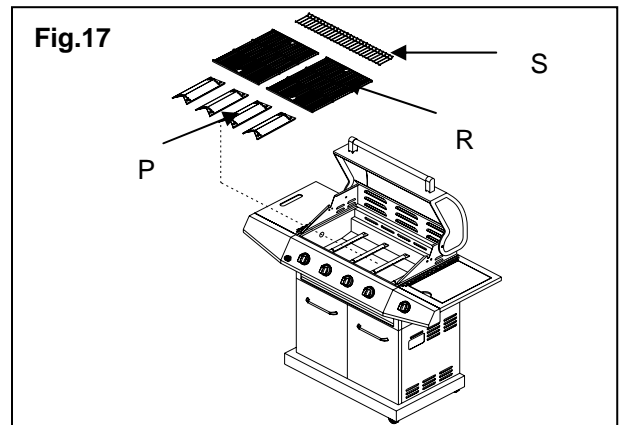
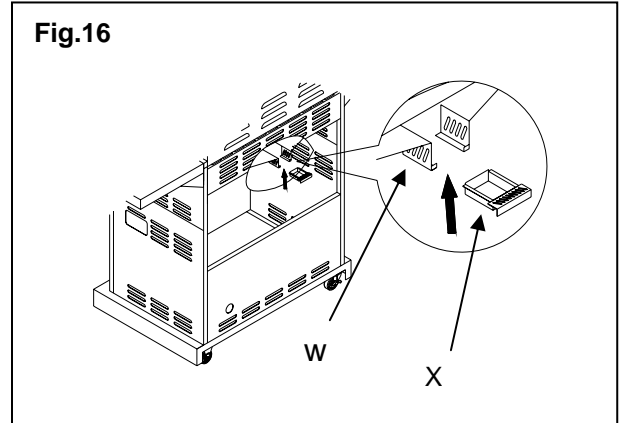

8. Connecting LP Gas Tank to LP Grill

- (a) From front of the cart, place foot ring of 20 lb tank into the hole in bottom panel. Make sure the tank valve is in OFF position. Use the tank bolt to secure the tank in a fixed position (Fig.19).
- (b) Check the tank valve to ensure it has proper external mating threads to fit the hose and pressure regulator assembly provided.
- (c) Make sure all burner valves are in OFF position.
- (d) Inspect the valve connection port and pressure regulator assembly. Look for damage or debris. Remove any debris. Inspect hose for damage. Never use damaged or plugged equipment.
- (e) When connecting pressure regulator and hose assembly to tank valve, hand tighten quick coupling nut clockwise to a full stop. (Fig.20) Do not use a wrench to tighten because it could damage the quick coupling nut and result in a hazardous condition.
- (f) Slowly open tank valve fully (counterclockwise). Use a soapy water solution to check all connections for leaks before attempting to light your grill (see next page for gas leak check instructions). If a leak is found, turn tank valve off and do not use your grill until the leak is repaired.

CAUTION: When the appliance is not in use, gas must be turned off at the supply tank.

DISCONNECTING THE LIQUID PROPANE CYLINDER

Turn the grill burner valves "OFF" and make sure the grill is cool.

Turn the Liquid Propane Cylinder valve "OFF" by turning clockwise until it stops.

Detach the pressure regulator assembly from the cylinder valve by turning the quick coupling nut counterclockwise.

Place dust cap on cylinder valve outlet whenever the cylinder is not in use. Only install the type of dust cap on the cylinder valve outlet that is provided with the cylinder valve. Other types of caps or plugs may result in leakage of propane.

Fig.19

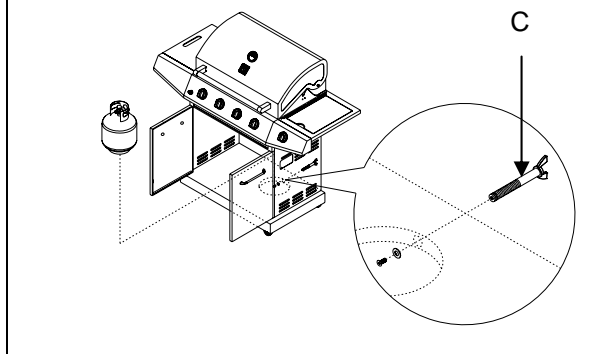
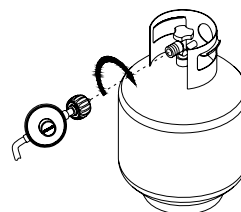

Fig.20

pressure regulator
Connection



Congratulations

Your Kenmore gas grill is now ready for use. Before the first use and at the beginning of each season (and whenever the LP gas tank has been changed):

1. Read all safety, lighting and operating instructions.
2. Check gas valve orifices, burner tubes and burner ports for any obstructions.
3. Perform gas leak check according to instructions found on next page of the manual.

Important

Before cooking on your grill the first time, wash cooking grids and cooking rack with warm, soapy water. Rinse and dry thoroughly. Season with cooking oil regularly. After cooking is completed, turn grill to HIGH setting for 3 to 5 minutes to burn off excess grease or food residue.

Checking for LP gas leaks

Never test for leaks with a flame. Prior to first use, at the beginning of each season, or every time your LP gas tank is changed, you must check for gas leaks.

1. Make a 50/50 (soap/water) mild soap solution.
2. Turn the control knobs to full OFF position; then turn gas ON at supply tank.
3. Apply the soap solution with a clean brush to all gas connections. See below. If growing bubbles appear in the solution the connections are not properly sealed. Check each fitting and tighten or repair as necessary.

Gas Connection Leak Check



4. If you have a gas connection leak you cannot repair, turn gas OFF at supply tank, disconnect fuel line from your grill and call 1-800-913-8999 (English) or 1-800-648-5864 (French) or your gas supplier for repair assistance.
5. Also apply soapy solution to the tank seams. See below. If growing bubbles appear, shut tank OFF and do not use or move it! Contact an LP gas supplier or your fire department for assistance.

Gas Tank Leak Check

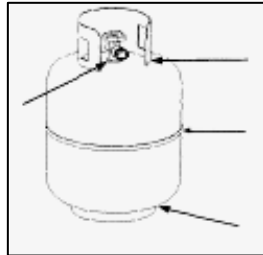

Grill Lighting Instruction

Grill Lighting Instructions for Main Burners

1. Do not smoke while lighting grill or checking gas supply connections.
2. Be sure that LP gas tank is sufficiently full.



WARNING

Failure to open grill lid during the lighting procedure could result in a fire or explosion that could cause serious bodily injury, death, or property damage.

3. Be sure all gas connections are securely tightened.
4. Turn on gas supply.
5. Open the grill main lid.
6. Push and turn any main burner control knob to HI ⚡ position. Push Electronic Ignition button for 3 to 5 seconds to light burner.



7. If the burner does not light after 5 seconds, turn knob to OFF. Turn gas OFF at LP tank and wait 5 minutes for gas to clear. Then turn gas ON at tank and repeat step 5
8. If burner still does not light, see Match Lighting section and If Grill Still Fails to Light section on following page.
9. To light additional burners, turn burner knob(s) to HI ⚡. Push and hold electronic ignition button to light burner. Adjust knob(s) to desired setting.

USING THE SIDE BURNER:

Inspect the gas supply hose prior to turning the gas "ON". If there is evidence of cuts, wear or abrasion, it must be replaced prior to use. Do not use the side burner if the odor of gas is present.

WARNING: Always keep your face and body as far away from the burner as possible when lighting.

LIGHTING INSTRUCTIONS FOR SIDE BURNER

1. Open side burner lid fully.
2. Push and turn side burner knob to HI ⚡ position. Push and hold Electronic Ignition button for 3-5 seconds to light burner.
3. If the side burner does not light after 5 seconds, turn knob to OFF. Turn gas OFF at LP tank and wait 5 minutes for gas to clear. Then turn gas ON at tank and repeat step 2.
4. If burner still does not light, see Match Lighting section and If Grill Still Fails to Light Section on following page.





WARNING

Never lean over the grill cooking area while lighting your gas grill. Keep your face and body a safe distance (at least 18 inches) from the cooking grid surface when lighting your grill by match.

Manually Lighting Your Grill by Match

1. Insert a match into the manual lighting stick.
2. Follow steps 1 through 5 of the Basic Lighting Procedure.
3. Light the match and extend the lighting stick to cooking grid surface.
4. Turn the desired control knob to the **HI** position setting to release gas. The burner should light immediately.

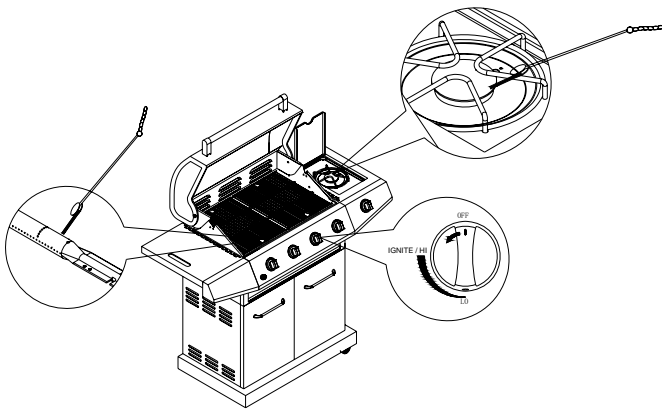

WARNING

Should a “FLASH-BACK” fire occur in/or around the burner tubes, follow the instructions below. Failure to comply with these instructions could result in a fire or explosion that could cause serious bodily injury, death, or property damage.

- Shut off gas supply to the gas grill.
- Turn the control knobs to OFF position.
- Put out any flame with a proper fire extinguisher.
- Open grill lid.
- Once the grill has cooled down, clean the burner tubes and burners according to the cleaning instructions found on page 18.

If Grill Still Fails To Light

1. Check gas supply and connections for leaks. Check that all wire connections are secure.

2. Repeat basic lighting procedure. If your grill still fails to operate, turn the gas off at source, turn the control knobs to OFF, then check the following:

- Misalignment of burner tubes over orifices

Correction: Reposition burner tubes over orifices.

- Plugged orifice

Correction: Remove burners from grill, carefully lift each burner up and away from gas valve orifice. Remove the orifice from gas valve and gently clear any obstruction with a fine wire. Then reinstall all orifices, burners, and cooking components.

3. If an obstruction is suspected in grill burner valves, please call for repair service at 1-800-913-8999 (English) or 1-800-648-5864 (French) .

4. If the grill still does not light you may need to purge air from the gas line or reset the pressure regulator excess gas flow device. **Note:** This procedure should be done every time a new LP gas tank is connected to your grill.

To purge air from your gas line and/or reset the pressure regulator excess gas flow device:

- Turn all control knobs to the OFF position.
- Turn off the gas at the tank valve.
- Disconnect pressure regulator from LP gas tank.
- Let unit stand for 5 minutes.
- Reconnect pressure regulator to the LP gas tank.
- Turn the tank valve on slowly until $\frac{1}{4}$ to $\frac{1}{2}$ open.
- Open the grill lid.
- Push and turn any control knob to HIGH.
- Turn control knobs to HIGH until all the burners are lit
- You may start to use the grill

5. If all checks or corrections have been made and you still have questions about operating your gas grill, call the **Grill Information Center at 1-800-913-8999 (English) or 1-800-648-5864 (French)**

Cleaning and Maintenance

To ensure a proper working unit the following proper care and maintenance is suggested.

Cleaning Cooking Grids

We suggest you wash your cooking grids in a mild soap and warm water solution. You can use a wash cloth or soft brush to clean your cooking grids.

Cleaning Heat Diffusers

Periodically you should wash the heat diffusers in a soap and warm water solution. Use a soft brush to remove stubborn burnt-on cooking residue. The heat diffusers should be dry before you reinstall them.

Cleaning Grease Tray

The grease tray should be emptied and wiped down periodically and washed in a mild detergent and warm water solution. A small amount of sand or cat litter may be placed in bottom of grease tray to absorb the grease. Check the grease tray frequently, don't allow excess grease to accumulate and overflow out of the grease tray.

Annual Cleaning of Grill Interior

Burning-off the grill after every use will keep it ready for your next use. However, once a year you should give the entire grill a thorough cleaning to keep it in top operating condition. Follow these steps.

1. Turn all burner valves to full OFF position.
2. Turn LP gas tank valve to full OFF position.
3. Detach LP gas hose and pressure regulator assembly from your gas grill. Inspect for any damage and replace as necessary with manufacturer replacement part number found on parts list.
4. Remove and clean heat diffusers, cooking grids and grill burners.
5. Cover each gas valve orifice with aluminum foil.
6. Brush inside and bottom of grill with a nylon brush, and wash with a mild soap and warm water solution. Rinse thoroughly and let dry.
7. Remove the aluminum foil, then reinstall heat diffusers, and cooking grids.
8. Reconnect gas source and observe burner flame for correct operation.

Cleaning Exterior Surface

We suggest you wash your grill using a mild soap and warm water solution. You can use a wash cloth or sponge for this process. Do not use abrasives or a brush that might remove finish during the cleaning process.

Cleaning Exterior Stainless Steel Surfaces

Weathering and extreme heat can cause exterior stainless steel surfaces to turn tan in color. Machine oils used in manufacturing process of stainless steel can also cause this tanning color. Use a stainless steel cleaner to polish stainless steel surfaces of your grill. Never use abrasive cleaners or scrubbers because they will scratch and damage your grill.

Cleaning Burner Tubes and Burner Ports

To reduce the chance of "FLASH-BACK" the procedure below should be followed at least once a month in late summer or early fall when spiders are most active or when your grill has not been used for a period of time.

1. Turn all burner valves and gas tank valve to off position.
2. Detach the LP gas pressure regulator assembly from your gas grill.
3. Remove cooking grids, heat diffusers, and grease tray from the grill.
4. Remove the screws from the underside of each burner and lift the burners up and away from the gas valve orifice.
5. Using a bent stiff wire in the shape of a hook, air hose or a bottle brush, run it through the burner tube and inside several times to remove any debris.
6. Replace burners, see illustration below.
Step 1. Remove screw which locks ignite wire.
Step 2. Take off R clip which fixes burner at the end side.
Step 3. Locate the new burner onto the orifice.
(a) Insert the burner over the main burner gas valve.
(b) Make sure the orifice stud (C1) is inside the burner venturi (D1) as shown in (Fig.21).
Step 4. Secure the main burner on the back wall use R clip, and fix on ignite wire.



Fig. 21

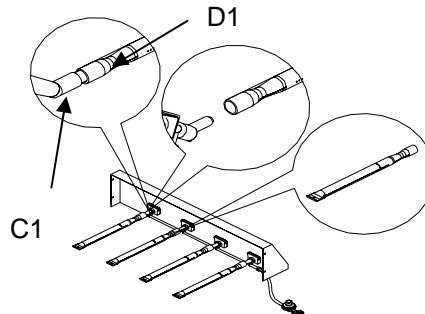

 **WARNING**

The location of the burner tube with respect to the orifice is vital for safe operation. Check to ensure the orifice is inside the burner tube before using the gas grill. If the burner tube does not fit over the valve orifice, lighting the burner may cause explosion and/or fire.

Regardless of which burner cleaning procedure you use, we recommend you also complete the following steps to help prolong burner life.

1. Use a fiber pad or nylon brush to clean the entire outer surface of each burner until free of food residue and dirt.

2. Clean any clogged ports with a stiff wire, such as an open paper clip.
3. Inspect each burner for damage (cracks or holes) and if such damage is found, order and install a new burner. After installation check to ensure that gas valve orifices are correctly placed inside the ends of the burner tubes.

 **WARNING**

Spiders and insects can nest inside the burners of the grill and disrupt gas flow. This very dangerous condition could cause a fire behind the valve panel, thereby damaging the grill and making it unsafe for operation. Inspect the grill at least twice a year.

Troubleshooting

BEFORE CALLING FOR SERVICE

If the grill does not function properly, use the following check list before calling for service.

You should inspect the burners at least once a year or immediately after any of the following conditions occur:

PROBLEMS	WHAT TO DO
Grill won't light when the control knob is rotated.	Check to see if LP tank is empty. Clean wires and/or electrode by rubbing with alcohol and clean swab. Wipe with dry cloth. Make sure the wire is connected to electrode assembly. Do other burners on the unit operate? Check to see if other burners operate. If so, check the gas orifice on the malfunctioning burner for an obstruction.
Burner flame is yellow or orange, in combination with the odor of gas.	Refer to Clean Burner Tubes and Burner Ports on page 19. If problem still exists, please call 1-800-913-8999.
Low heat with knob in "HI" position.	Is the fuel hose bent or kinked? Is the grill in a dusty area? Is there adequate gas supply available? If it is only one burner that appears low, does the orifice or burner need cleaning? Is the gas supply or gas pressure low?

Cooking Instructions



WARNING

Do not leave the grill unattended.
Your grill will get very hot. Never lean over the cooking area while using your grill. Do not touch cooking surfaces, grill housing. Grill Lid or any other grill parts while the grill is in operation, or until the grill has cooled down after use. Failure to comply with these instructions may result in serious bodily injury.

Burn-off

Before cooking on your gas grill for the first time, you will want to “burn off” the grill to eliminate any odor or foreign matter. Just ignite the burners, lower the Lid, and operate grill on the HIGH setting for 3 to 5 minutes.

Cooking Temperatures

High setting: Only use this setting for fast warm-up, searing steaks or chops and for burning food residue off the grill after cooking is complete. **Never** use the HIGH setting for extended cooking.

Medium to Low Settings: Most recipes specify medium to low settings, including all smoking, rotisserie cooking and for cooking lean cuts such as fish.

NOTE: Temperature settings will vary with the temperature and the amount of wind outside your home.

Direct Cooking

The direct cooking method can be used with the supplied cooking grids and food placed directly over the lit grill Burners. The method is ideal for searing and whenever you want meat, poultry or fish to have and open-flame barbecued taste. Deep frying and smoking are also best cooked in this manner because they require direct heat.



WARNING

Do not line the bottom of the grill housing with aluminum foil, sand or any substance that will restrict the flow of grease into the grease tray. Failure to comply with these instructions could result in a fire or explosion which could cause serious bodily injury, death, or property damage.

Indirect Cooking

To cook **indirectly**, the food should be placed on the left or right side of your grill with the burner lit on the opposite side.

Flare-ups

The fats and juices dripping from grilled food can cause flare-ups. Since flare-ups impart a favorably, distinctive taste and color to food cooked over an open flame, they should be accepted up to a point. Nevertheless, uncontrolled flaring can result in a ruined meal.

Grill Cooking Chart

Warning: To ensure that it is safe to eat, food must be cooked to the minimum internal temperatures listed in the table below.

Food	Temperature
Beef, veal and lamb (pieces and whole cuts) - medium-rare	63° C (145° F)
Beef, veal and lamb (pieces and whole cuts) - medium	71° C (160° F)
Beef, veal and lamb (pieces and whole cuts) - well done	77° C (170° F)
Pork (pieces and whole cuts)	71° C (160° F)
Poultry (e.g. chicken, turkey, duck) - pieces	74° C (165° F)
Poultry - whole	85° C (185° F)
Ground meat and meat mixtures (e.g. burgers, sausages, meatballs, meatloaf, casseroles) - beef, veal, lamb and pork	71° C (160° F)
Ground meat and meat mixtures - poultry	74° C (165° F)
Egg dishes	74° C (165° F)
Others (hot dogs, stuffing and leftovers)	74° C (165° F)

From: Canadian Food Inspection Agency

FOOD	Weight or thickness	Temperature	Time	Special instructions and tips
Vegetables	NA	Medium	8 to 20 minutes	Slice or chop vegetables and dot with butter or margarine. Wrap tightly in heavy duty foil. Grill turning occasionally.
Potatoes	Whole	Medium	40 to 60 minutes	Wrap individually in heavy duty foil. Cook rotating occasionally.
Meat/Steaks	1/2 to 3/4 inches	High-Medium	4 to 15 minutes	Pre heat grill for 15-20 minutes then sear steaks on each side for two minutes. Next grill 3 to 5 minutes on each side or until desired doneness.
Ground Meats	1/2 to 3/4 inches	Medium	8 to 15 minutes	Grill turning once when juices rise to the surface or until desired amount of doneness. Do not leave hamburgers unattended since a flare-up could occur quickly.
Ribs	1/2 or full rack	Medium	20 to 40 minutes	Grill turning occasionally. During last few minutes brush with barbecue sauce, turn several times.
Hot dogs	NA	Medium	5 to 10 minutes	Grill turning four times. 2-4 minutes on each of four sides.
Poultry-Cut	1/4 to 1/2 pounds	Low or Medium	20 to 40 minutes	Grill turning occasionally. During last few minutes brush with barbecue sauce if desired, turn several times.
Poultry Whole	2 to 3 pounds	Low or	1 to 1-1/2 hours	Use poultry stand and brush frequently as desired
		Medium	40 to 60 minutes	Use poultry stand and brush frequently as desired
Fish	3/4 to 1 inch	Medium	8 to 15 minutes	Grill turning once to desired doneness. Brush with melted butter, margarine or oil.