



HEADLIGHTS INSTRUCTION MANUAL

7" Round

FT-7RD-HL, FT-7RD-2KIT



HiViz LED Lighting
HiViz Lighting, Inc
Phone: 703-662-3458
Email: sales@hivizleds.com
PO Box 565, Naples, NC 28760



TABLE OF CONTENTS

Safety Notice & Warranty.....3

7" Round: What's Included.....4

Technical Specifications.....5

Wiring Information.....6

Installation Instructions.....7

Frequently Asked Questions.....8-10

References.....11



SAFETY NOTICE & WARRANTY

WARNING: INSTALLATION MUST BE CONDUCTED BY A QUALIFIED TECHNICIAN.

IMPROPER INSTALLATION CAN RESULT IN INJURY OR DEATH.

- Installation must be conducted by a qualified automotive electrician or emergency vehicle technician in accordance with the applicable NFPA standard(s) and procedures (Including but not limited to NFPA 1901, 1906, 1911, 414, 1900)
- Improperly installed, aimed, or operated lights can create significant hazard to motorists which can result in collision. Ensure light fixtures are installed and operated such that their beam does not shine into oncoming traffic
- All circuits must be fused at 125% of the rated power consumption of the loads on the circuit
- A voltage drop greater than 10% in the power feed to a fixture could be an indicator of an under-sized conductor. Use of improperly sized conductors will, at a minimum, result in poor performance, and at a maximum could result in fire
- Verify input voltage is within fixture range before installation. Voltage range information can be found in this manual or printed on the fixture body
- The use of personal protective equipment (safety glasses and gloves) is highly recommended
- Allow proper cooling time before handling the fixture if it has been installed & powered to prevent burns
- Any modifications to the fixture will void warranty and are not authorized by the manufacturer
- Always inspect the fixture for any damage prior to installing and DO NOT install if any damage is present



PLEASE READ ALL INSTRUCTIONS BEFORE INSTALLATION



Warranty Information: Full policy available Online at www.hivizleds.com/warranty

- Proof of purchase may be required to validate warranty. All FireTech products are warranted for the useful service life of the vehicle for which they were first installed
- Improper installation, accident, physical damage, neglect, and normal wear and tear are not covered under warranty
- Lights operated in environments over 150° Fahrenheit are not covered under warranty
- All advance-exchange warranty claims must be validated with HiViz Technical Support prior to issuance of a shipping label. Failure to return defective product will result in an invoice for the full replacement value of the product
- HiViz Lighting will repair or replace defective product at its discretion. Replacement product will be in similar or better cosmetic condition than the defective part
- Warranties should be handled through the dealer/reseller the product was purchased from; customer is responsible for delivery
- If product is found to have damage not covered under warranty, customer will be responsible for return shipping charges and/or cost of repair
- Non-warranted items can be repaired at the customer's expense of parts and labor, at the discretion of HiViz LED Lighting, who will provide an estimated repair cost before proceeding with the repair



7" ROUND: WHAT'S INCLUDED

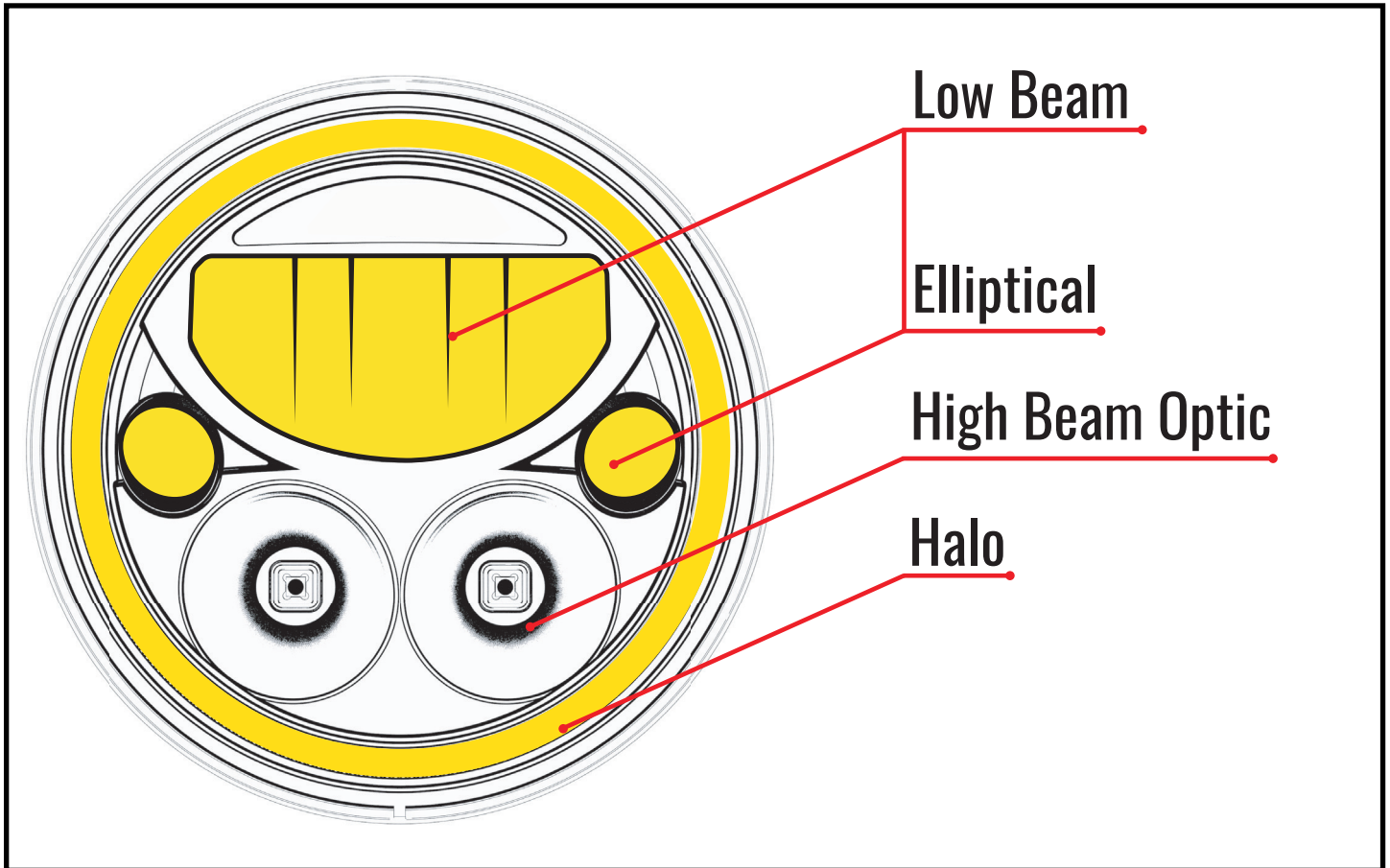

TOOLS REQUIRED

- Female Spade Connectors
- Misc Automotive Primary Wire
- Multi Meter or Test Light
- Small, Flat Screwdriver if repinning is required

WARNING:

Tighten screws by hand/screwdriver. Pneumatic devices can cause damage and void warranty.

TECHNICAL SPECIFICATIONS

7" ROUND LED HEADLIGHT

BEAM MODES	HIGH/LOW, HALO
WATTAGE	43W
AMP DRAW (@12V)	3.58A
INPUT VOLTAGE	9-32V DC
REFLECTOR COLORS	CHROME, BLACK CHROME
OPERATING RANGE	-40F TO +176F

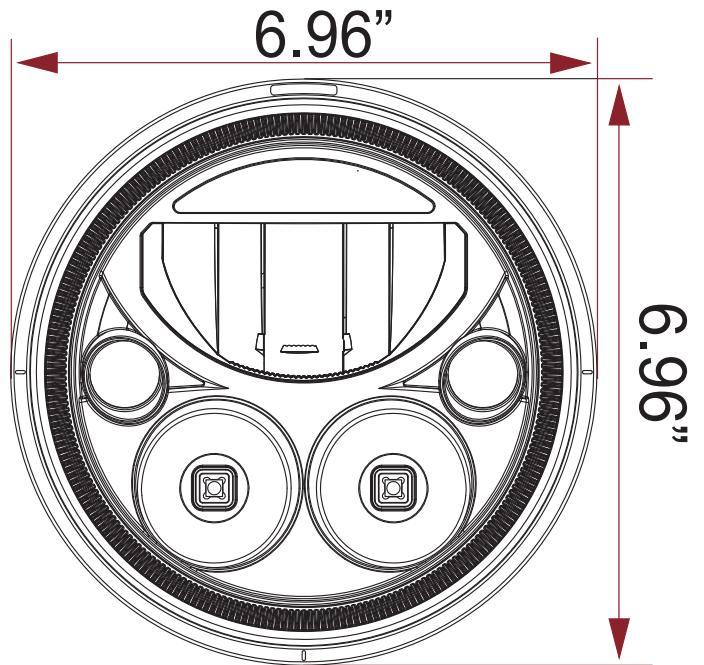

ITEM

DESCRIPTION

FT-7RD-HL	7" Headlight DOT High / Low (For Low Beam Use)
FT-7RD-HL-KIT	7" Headlight Kit of 2 DOT High / Low (For Low Beam Use)

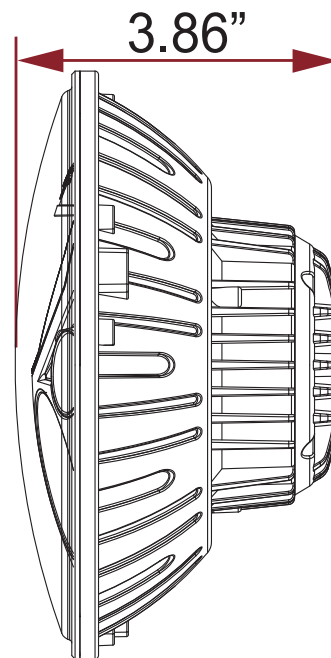

WIRING INFORMATION

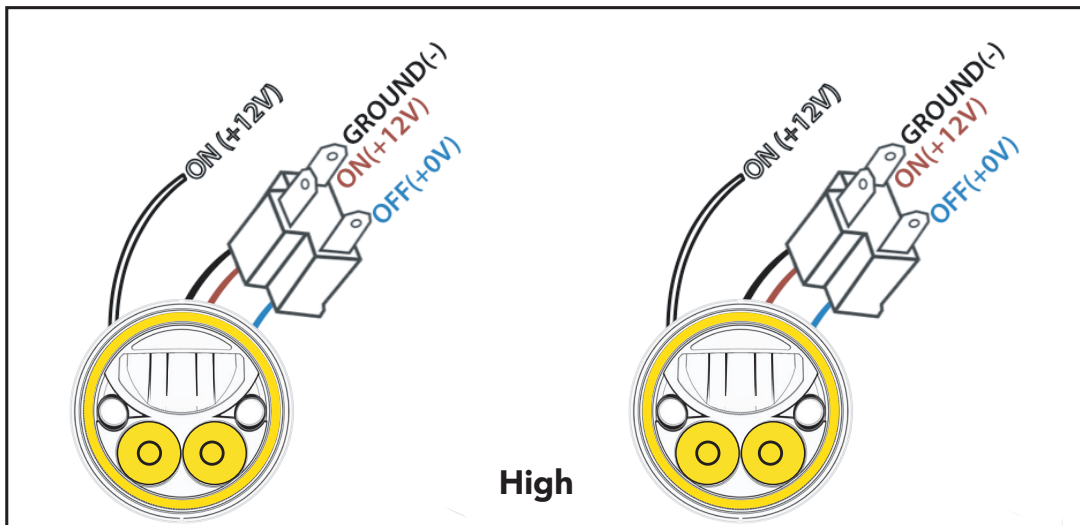
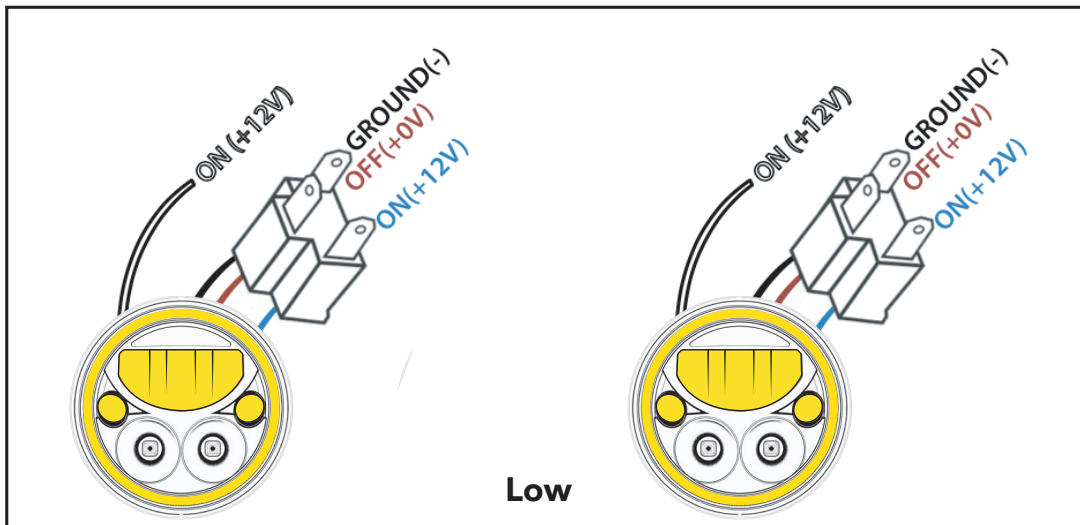
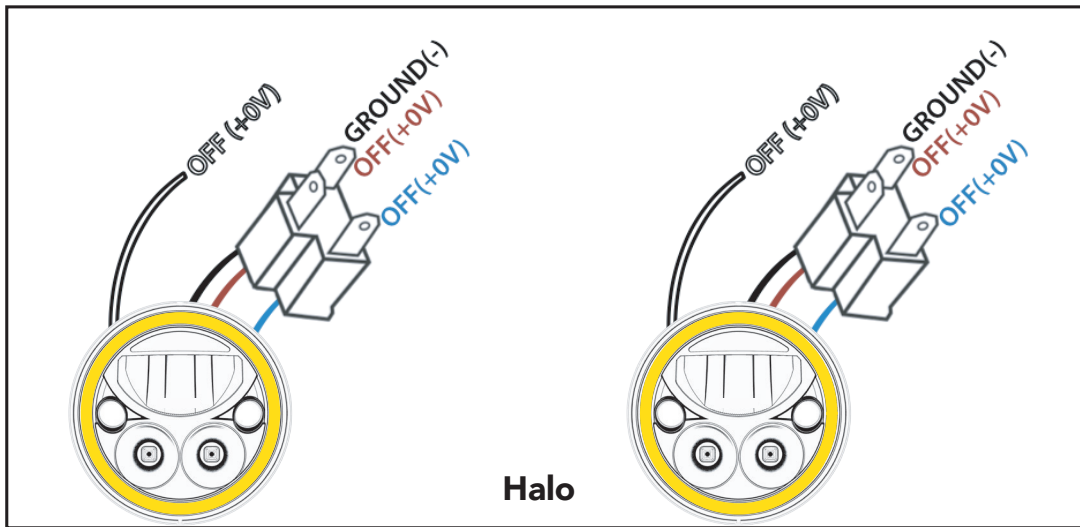

INSTALLATION INSTRUCTIONS

1. Unscrew existing headlight bezel hardware. Remove and set aside bezel.
2. Remove old headlight bulb(s).
Tip: Start with 2 screws, then have a helper press the headlight into the housing while you remove the other 2 screws to prevent the headlight from falling out.
3. Repeat above steps for all (either both, or 4 headlights) prior to installing new fixtures.
4. Run a power wire from the marker light circuit on the apparatus to each of the headlight buckets. This will be used to connect the halo power wires. Refer to video link below for more information.
7. Plug the connector into the factory wiring and attach the halo wire to the marker light circuit from step 4 (above). Insert the body of the headlight into the mounting bucket and install the retaining ring using the 4 screws removed in step 2. Be careful not to allow any connectors or terminals to come in contact with the headlight mounting bucket.
8. Test operation of the headlight system. Click 1 of the headlight switch should turn on the halos, click 2 should turn on the low beams, cycling the high beam switch should disengage the low beams and engage the high beams. If any problems exist, troubleshoot and/or contact HiViz for more information.
9. Reinstall headlight bezels from step 1. Be sure not to over-torque as this will cause cracking of the headlight bezel assembly! Check for proper orientation prior to re-installation (look at adjustment screws).
10. Aim headlights per FMVSS108 requirements for a "VOR" headlight system.
11. Now that your new headlights are securely in place, you're vehicle is now ready for use.

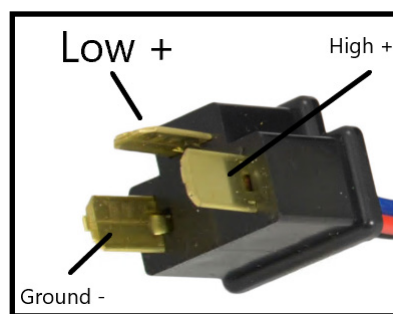

Pin Reference



FREQUENTLY ASKED QUESTIONS

1. What color wires on your headlights correspond to what functions?

Please refer to the wiring diagram on page 6. Generally, black = ground, red = high beam, blue = low beam, and white = +12v "parking" light (marker lights).

2. Do I need heated headlights?

Most customers do NOT need heated headlights when choosing a FireTech headlight for their apparatus. Our headlights are designed to operate flawlessly down to -40 °F.

4. What do I do with the halo wires?

The halo wires should be wired to the closest "parking light" circuit on the truck. This circuit is the circuit that powers all of the apparatus marker lights when the headlight switch is in the "first" position.

5. Can I wire the halos to the low beams?

No. While technically functional, it is not the appropriate use of the SAE "P" parking light circuit in the FireTech headlight. The halo wire should be wired to the parking/marker light circuit on the apparatus.

6. Will wig-wagging hurt the headlights? / Can I use them with wig-wag?

Wig-wagging does not cause a problem for the FireTech headlight. In some instances, if the wig-wag module does not operate correctly post-installation, adding a resistor kit may be helpful. Please contact HiViz Lighting if you have questions or need troubleshooting support. LED Light resistor kits are generally available at your local auto parts store.

7. Are the headlights waterproof?

FireTech headlights are rated IP69K, which means they are designed for sustained high pressure spray. The GORE PolyVent on the headlight is designed to allow for pressure equalization but is not designed for submersion. If your application calls for fully submersion rated operation, please contact HiViz Lighting for a PolyVent delete kit.

8. What is the warranty?

FireTech headlights are guaranteed to be free from defects in materials and workmanship for the operational service life of the apparatus which they were first installed. We are not in the headlight rental business and request you do not move headlights from truck to truck. This warranty does NOT cover physical damage (cracking, scratching, melting, etc).



FREQUENTLY ASKED QUESTIONS

9. Are they plug and play?

In most applications for fire apparatus manufactured in North America, the FireTech headlight drops right in place and requires no additional wiring (other than the halo wires if desired). There are three exceptions:

A. If your fire apparatus does not have standard H4 plugs (different connector), an adaptor harness may be required. Please contact HiViz for more information.

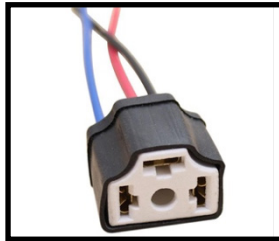

H4 (standard) plug

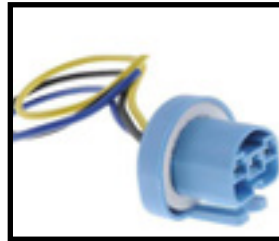

**9007/9004 plug
(requires adaptor)**

B. If your headlights do not operate at all when installed

In legacy headlight systems (halogen), it was not as important that the ground and power be in the correct polarity orientation at the OEM. With LED headlights, it is critical to be wired with the correct polarity for operation. If your headlights do not operate correctly, the most likely problem is mismatching high/low/ground pins. To rectify, use a multimeter or test light to identify which wires correspond to low beam, high beam, and ground on your apparatus, and move pins on FireTech headlight to match. Pins can be popped out of the connector using a small flat screwdriver pressed in to the back of the pin. Please contact HiViz technical support if you require assistance or would prefer to have someone walk you through this process. It's totally acceptable to facetime our team and an EVT will guide you through the process!

C. If your apparatus had a Daytime Running Light provision from the factory, a bypass or reprogramming may be required.

This is very common in Canada and on some years of KME apparatus with EsKey multiplex systems. While less common, it can occur on other apparatus as well. If the headlights flicker, flash, or do not seem to operate properly post-installation, first verify all wiring is correct (low to low, high to high, and ground to ground), then contact HiViz Tech support for more information. There has never been a fire apparatus with 4x6 headlights we are unable to support remotely.



FREQUENTLY ASKED QUESTIONS

10. Why is there a dark spot at about 25ft?

The FireTech headlights are designed to illuminate 3 distinct zones: the foreground (area between the bumper and bottom of the low beam), the standard "low beam" zone, and the "high beam" zone. If you look at the front of the headlight, the two angled circular optics on the front provide a fill-in light in that first foreground zone. If those were turned "off", you would see a beam pattern much more similar to other over-the-road vehicle headlight applications. With the FireTech headlights, those fill-in optics produce a high output wash near the apparatus which helps illuminate areas near the apparatus when responding or on scene. The beam pattern is different by design, not a design defect.

11. Do they come with the buckets?

7": No. FireTech headlights are sold as individual replacement lamps for a sealed beam headlight. Buckets for 4x6 headlights are commercially available from various sources. Please contact HiViz for more info.



REFERENCES



For additional information, please visit hivizleds.com



7-inch Headlights
Product Page



Halo Installation
Video





HiViz LED LIGHTING
HiViz Lighting, Inc
Phone: 703-662-3458
Email: sales@hivizleds.com
PO Box 565, Naples, NC 28760