



**CHISELSTONE
HILLTOP CONCRETE**
18775 FM 2493
Flint, TX 75762
(903) 630-5465

Specifications and Notes

General:

- This project has been designed in accordance with the International Building Code, 2010 Edition.
- Applied loads:
 - Wind Velocity (V) = 90 mph
 - Exposure: B
 - Importance Factor (I) = 1.0
 - Velocity Pressure Exposure Coefficient (Kz) = 0.70
 - Wind Directionality Factor (Kd) = 0.85
 - Topographic Factor (Kzt) = 1.0
 - Wind Pressure $P = 0.00256(Kz)(Kd)(V^2)(I)$
 $P = 0.00256(0.70)(1.0)(0.85)(90)^2(1.0)$
 $P = 12.3$ psf
 - Working Design Stress: 33% Increase (1.33)
 - Seismic Design: Site Class D
- Precast components to be manufactured by Artisan Precast
 - Posts, Panels and Panel caps shall be precast off-site.
 - Screening wall is to be erected entirely on the project property.
 - Piers/Footings are to be cast in place on site.

Concrete

- Concrete Materials:
 - Concrete shall be normal weight concrete having sand and gravel or crushed stone aggregate. Mixed with ASTM-C150, type I or III portland cement to meet the minimum compressive strength as follows:
 - panels & post: 5000 psi @ 28 days
 - footings & piers: 3000 psi @ 28 days
 - sidewalk & non-structural: 3000 psi @ 28 days
 - Water used for concrete shall be clean water and free from injurious amounts of oils, acids, alkalis, organic or other deleterious substances.
 - All concrete permanently exposed to the weather shall contain an air-entraining admixture resulting in 3 to 6 percent entrained air or recommended by the manufacturer.

- Concrete workmanship:
 - Fresh poured concrete shall be tamped in to place using steel rammer, slicing tools, or mechanical vibrator, until concrete is thoroughly compact and without void.
 - Excavation for footing shall be on undisturbed soil or to the depth noted on the drawings. Leave the bottom bearing surface clean and smooth. If footing excavations are made deeper than intended, only concrete shall be used for fill. Remove all loose material from excavations prior to concrete pour.

Reinforcements:

- Reinforcing material:
 - Deformed type bars shall conform to ASTM-A 615, Grade 60 placed as shown on the drawings.
 - Steel reinforcing wire shall meet U.S. Steel Wire gauge, ASTM-A E2. fy = 70,000 psi min galvanized.
 - All ties and stirrups shall conform to the requirements of ASTM-A/ 615, grade 40.
 - All welded wire reinforcement shall be 4x12-D4/D4 having 3 horizontal bars and 5 vertical bars.

- Reinforcing workmanship:
 - Reinforcement steel shall be fabricated in accordance with the CRSI Standard Detail. Reinforcing bars shall be cold-bent only. Use of heat to bend reinforcement steel shall be cause for rejection.
 - Reinforcement steel bars and wire fabric shall be thoroughly cleaned before placing and again before the concrete is placed. Shall be accurately positioned and secured in place. No brick or porous materials may be used to support the steel off the ground.
 - Install all reinforcement with the following clearance between reinforcing steel and face of concrete:
 - Footing, pier or beam bottom (3")
 - Earth-formed pier or beam side (2")
 - Formed footing, pier or beam sides, exposed (1")
 - Precast exposed to weather: panels (3/4"), posts (1-1/4")
 - Splices within continuous unscheduled reinforcing steel shall have a minimum lap of 30 bar diameters.

- Soils**
- Footing size is based on the following minimum soil properties:
 - Soil Compaction ***** 90% stc. proctor
 - Bearing Capacity ***** 1,500 psf
 - Friction Resistance ***** 260 psf
 - Lateral Bearing ***** 100 psf/ft of depth

- Fill**
- All design criteria based on construction on natural ground. Screenwall not to be constructed on berms or fill dirt.

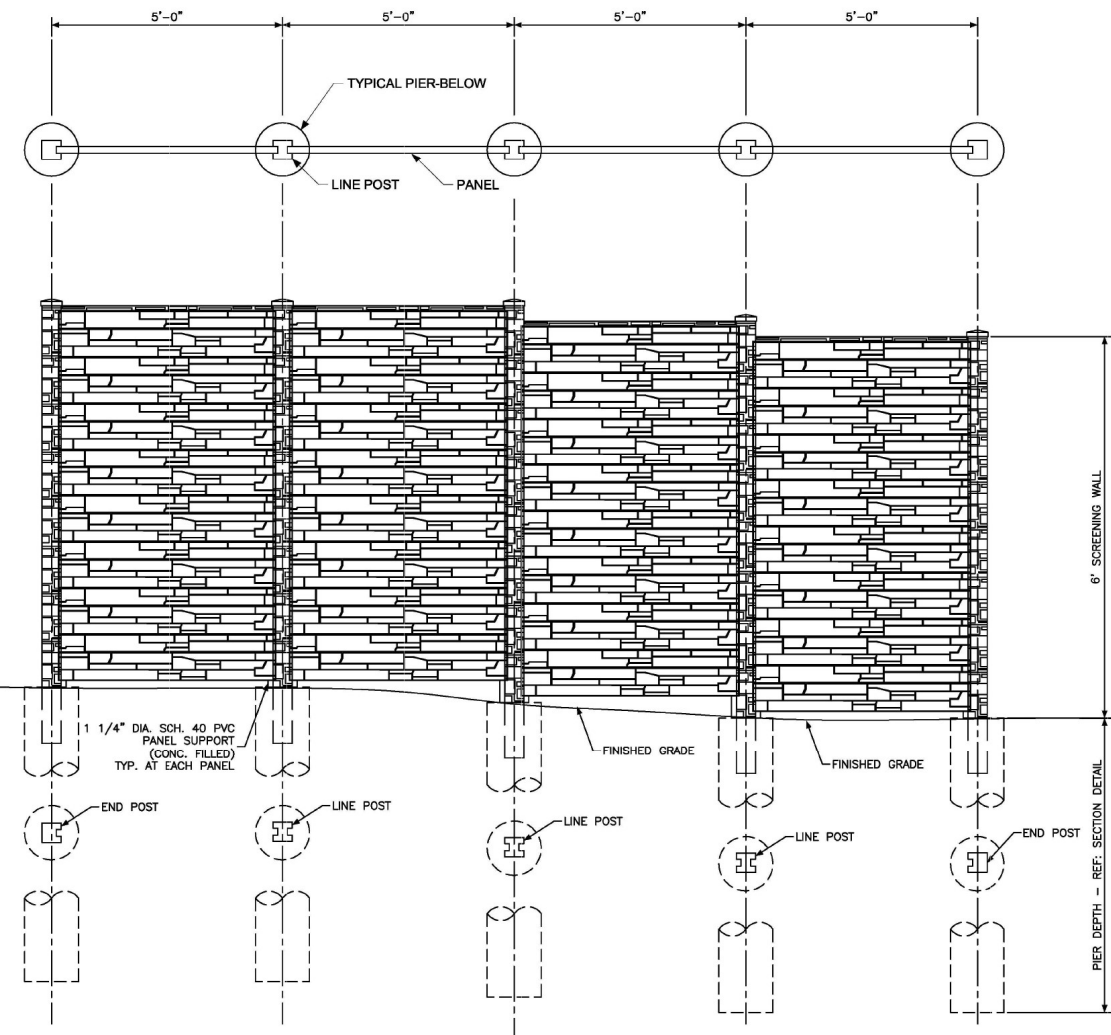

ELEVATION - 6' SCREENING WALL AND PIERS

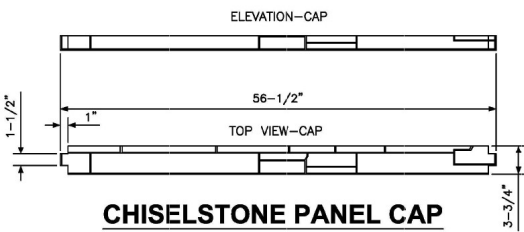

CHISELSTONE PANEL CAP

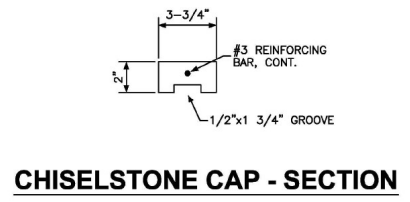

CHISELSTONE CAP - SECTION

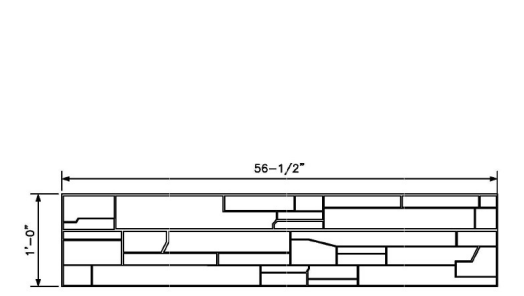

CHISELSTONE STANDARD PANEL

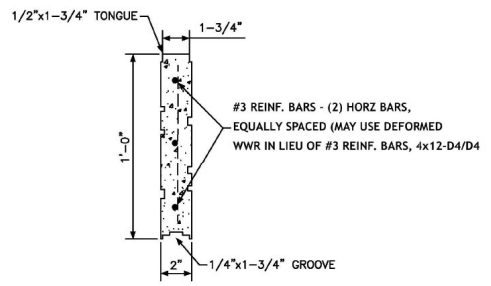

CHISELSTONE PANEL - SECTION

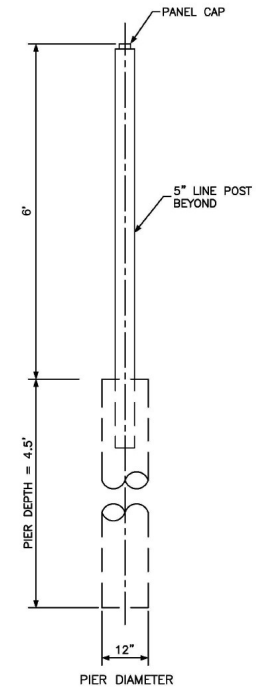

**SECTION - 6' SCREENING WALL AND PIER
LINE POST PIER**

LINE POST PIERS WILL HAVE NO REBAR.

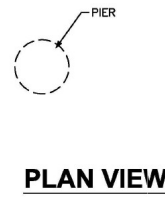

PLAN VIEW

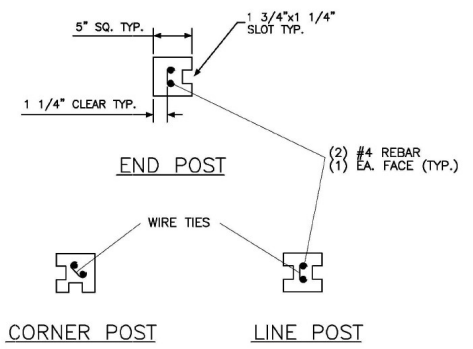

SECTION - 6' SCREENING WALL POST

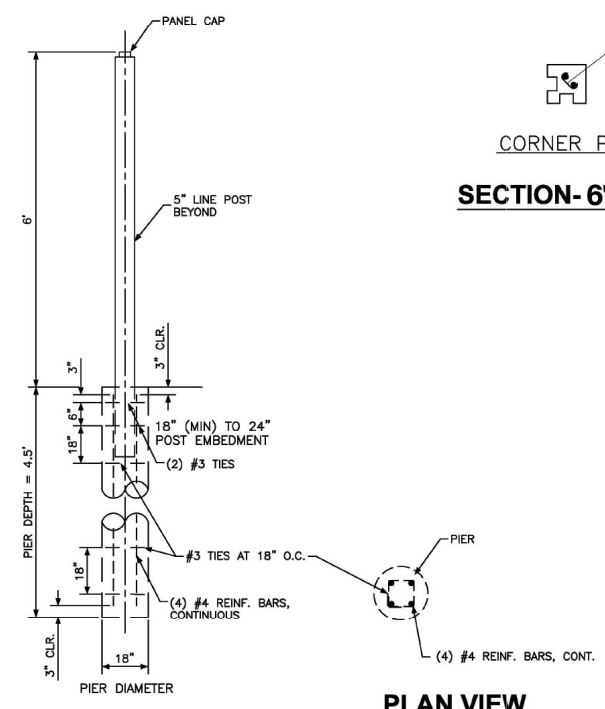

**SECTION - 6' SCREENING WALL AND PIER
END POST PIER**

END POST PIERS WILL HAVE REBAR.
END POST PIERS ARE DESIGNATED AS THE FIRST THREE POSTS AT THE END OF THE WALL.

PLAN VIEW

NO.	REVISION	DATE	DESIGNED	DRAWN	CHECKED