



PRESSALIT®



Design Guide
Kitchen





The right choice

Here at Pressalit we do not believe that disability need restrict people's lives. That is why we are the leading provider of furnishings and fittings for the sector.

We are known for expertise and for the quality and flexibility we build into all of our solutions.

In 1976, we developed the first bathroom systems made especially for disabled persons, and we have gained extensive experience in that field. In 2004, we began to focus on the kitchen with the same unflagging approach. We aspire to develop and offer solutions based on the needs of the user and the carer. At the same time, we seek to keep the important issues of economy and safety in mind.

Today we have an outstanding reputation as professional consultants where installing sanitary fixtures takes specialist knowledge of needs and spatial requirements.

We now wish to provide the same high level of advice in the kitchen design area. So from the start, we made best use of the latest research in the planning of kitchens for persons with physical disabilities by working together with leading specialists in this field.

Pressalit kitchen systems can be installed anywhere there is a need for flexible kitchen facilities.

To achieve the ultimate goal of an efficient kitchen, good professional advice and flexible solutions are essential.

Table of contents

Our philosophy	
The efficient kitchen	4
The flexible kitchen	5
Planning and installation	7
Systematic kitchen planning	
Spatial requirements	8
Free passage and turning area	9
The four kitchen types	10
Location of working areas	11
The washing-up area	12
The food preparation area	14
The cooking area	16
Storage	18
White goods	19
Sink and mixer taps	20
Essential details	21
Comfort zones	22
Height adjustment	23
Design proposals - linear design	24
Design proposals - L-shaped design	25
Design proposals - U-shaped design	26
Checklist	27



The efficient kitchen



Much more goes on in the modern kitchen than the mere cooking of meals. It is also a place where everyone comes together. If the user needs assistance, it is also a workplace for relatives and healthprofessionals. Everyone should feel equally at home there whether they suffer disablement or not.

An efficient kitchen that serves the needs of all can only be developed through a thorough knowledge of the user.

Consumer surveys tell us that healthprofessionals and relatives often do much of the kitchen work. At the same time, it is vital for those who are disabled to still be able to do as much as possible in the kitchen without calling on the assistance of others. Yet, that should not be a drain on time and energy resources.

Often the kitchen must be designed for not just one user but for several different users with a variety of needs. Professional carers have special requirements when it comes to safety and working environment. And a good kitchen solution has to offer all the combined features that management, administrators and planners envision.

The flexible system

The Pressalit efficient kitchen philosophy gathers all these issues into a common solution. We develop solutions to suit the individual situation – and every individual who is involved.

It is flexibility that counts as this provides users a much greater degree of independence and the ability to prioritise freely which activities can be managed alone. Moreover, there is greater freedom to request assistance when it is required. Such freedom of choice is of great importance where quality of life is concerned.

It is our firm conviction that the highest priority should be given to good working conditions in order to sustain the capacity for work as well and as long as possible – while helpers are provided adequate and accident-free work surroundings.

Pressalit's Indivo kitchen may, for example, be used for the fitting out of:

- communal kitchens and training kitchens, where many people of varying capabilities should be able to work together comfortably at the same time.
- kitchens in independent living units, where independent users should be able to work for themselves with or without a carer.

Indivo can be adjusted to both standing and seated users completely without problem.



Advantages for the user – standing or seated

Independence

Pressalit products help users to be as self-sufficient as possible. Our solutions fit individuals of all types – children, adults, those who can walk, and those who can sit.

Details

The system's efficient design, the choice of materials, and the perfection of detail all come together in the integrated kitchen setting – without compromising functionality or comfort.

Self-esteem

Being able to do things for oneself in safe surroundings that are pleasing to the eye creates self-reliance in daily routines.



Advantages for carers – standing or seated

Work environment

Using Pressalit products means a minimum of physical strain, faster and easier working and good working conditions.

Flexibility

Pressalit products can be adjusted to meet the specific needs of the primary user or users and of carers.

Respect

The flexibility of these products allows carers to assist users in their work in the kitchen – without users having to sacrifice their integrity and dignity.



Advantages for planners and administrators

Consultancy

All-round advice on the efficient kitchen guarantees that the space will match the needs of users and health personnel.

Meeting the needs of the future

Pressalit kitchen systems make conversion and remodelling unnecessary if users' needs change or if the kitchen is to be used by new users.

Design

With Pressalit you can focus on flexibility, functionality, and economy – without compromising on design or layout.



Planning and installation

How to plan and install a kitchen

The key to an efficient kitchen is systematic evaluation of the needs of users and carers – and evaluation of the possibilities which the space allows. In some situations, it must be possible for several users to cook and wash up at the same time. In others, meals may be delivered, and then only a small kitchen is required.

Naturally, the requirements of the user must come first but it is also important to allow for the various functions that a carer fulfils in the kitchen.

Carers carry out space demanding work on their own; in addition, they assist the user during work processes. So there has to be room for the carer around the user to enable him/her assist from any angle.

When designing a kitchen, there are a number of things to be considered:

Distance between the workstations

- is the total distance between sink/dishwasher, hob, and refrigerator.
This we calculate using a work triangle: a tool which can determine if the distance is too long.

Location of workstations

- actual correct positioning of the sink, the food preparation area and the cooking area relative to each other.

Number of users – and the role of user and carers

- how many will be using the kitchen at the same time. This must be assessed before assessing personal working capacity.

There may be only one user or one carer working in the kitchen at a time, for example:

- an independent user of mobility aids, who prepares meals alone,
- a carer or a family member who prepares meals for a disabled person.
Here the carer's role is to do the kitchen work for the user.

Or there may be several users and carers working in the kitchen at one time, for example:







- several people working independently of each other,
- several people working together,
- in situations where the carer's role is to assist the user.

On the following pages of this Kitchen Guide you will find a structural outline of the spatial needs that exist for a kitchen user with a carer and support aids. After that there is information about the work triangle and kitchen types, discussing the relationship of each workstation to the others.

The review also includes examples of our various kitchen models, with a checklist that can be useful in the planning phase.

For further information, please contact Pressalit.

Definition of symbols

-  Oven
-  Hob
-  Dishwasher
-  Refrigerator
-  Sink
-  Mobile storage unit







Note: The above symbols are used for the planning solutions in this kitchen design guide.



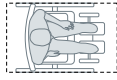
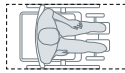

Spatial requirements

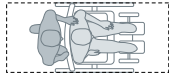
A kitchen has to be roomy enough for users with various mobility aids – either independently or with a carer.

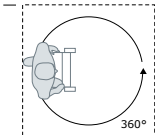
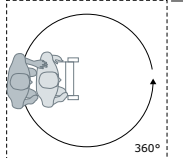
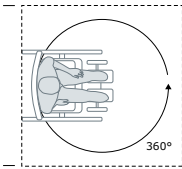
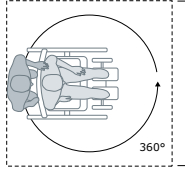
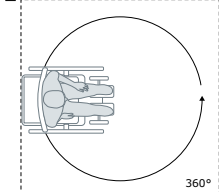
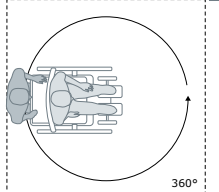
 <p>User</p>	 <p>600 600</p> <p>Person moving</p>	 <p>900 1000</p> <p>User with walking sticks</p>	 <p>750 1200</p> <p>User in manual wheelchair</p>	 <p>700 1300</p> <p>User in electric wheelchair</p>
 <p>Carer</p>	 <p>600 1000</p> <p>User and carer in motion</p>	 <p>750 1750</p> <p>Carer and user in manual wheelchair</p>		 <p>750 2000</p> <p>Carer and user in comfort wheelchair</p>
 <p>Space</p>	<p>Turning areas with and without carer</p> <p>Walking users – with walking sticks, crutches or rollator</p> <p>Turning area without carer: 1400 x 1400 mm Turning area with carer: 1700 x 1700 mm</p> <p>Users in manual wheelchairs</p> <p>Turning area without carer: 1700 x 1700 mm Turning area with carer: 1750 x 1750 mm</p> <p>Users in electric or comfort wheelchairs</p> <p>Turning area without carer: 2100 x 2100 mm Turning area with carer: 2100 x 2100 mm</p>	 <p>1400 x 1400 360°</p>	 <p>1700 x 1700 360°</p>  <p>1700 x 1700 360°</p>  <p>1750 x 1750 360°</p>  <p>2100 x 2100 360°</p>  <p>2100 x 2100 360°</p>	

Note: These measurements are Danish industrial standards (Dansk Standard 3029:2001). Turning area sizes should be viewed relative to the actual users in the type of institution or housing. On average the turning area should be 1700 x 1700 mm. Where users with major needs and larger mobility aids are concerned, the recommended area is 2100 x 2100 mm. All measurements are in mm.

Free passage and turning area

Free passage

Kitchen and hallways must allow for free passage.

Given a passage width of 1500-1700 mm a wheelchair user can turn in the passage at the same time.



Free passage

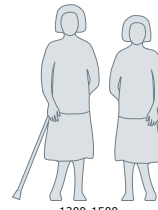

Free passage for two persons walking

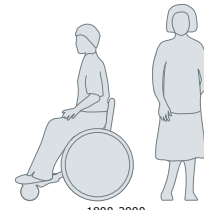

Free passage past a wheelchair

Independent user

with two walking sticks
with rollator
in a manual wheelchair
in an electric wheelchair

Turning area 90°

1100 x 1100 mm
1100 x 1100 mm
1400 x 1400 mm
1600 x 1600 mm

Turning area 180°

1300 x 1300 mm
1300 x 1300 mm
1500 x 1500 mm
1850 x 1850 mm

Turning area 360°

1400 x 1400 mm
1400 x 1400 mm
1700 x 1700 mm
2100 x 2100 mm

Carer with the user

in a manual wheelchair
in a comfort wheelchair

1750 x 1750 mm
2100 x 2100 mm

1750 x 1750 mm
2100 x 2100 mm

1750 x 1750 mm
2100 x 2100 mm

Room for manoeuvre

It is vital for the wheelchair user to have room enough to manoeuvre in the chair.

In front of every workstation in the kitchen there must be 1700 x 1700 mm turning area.

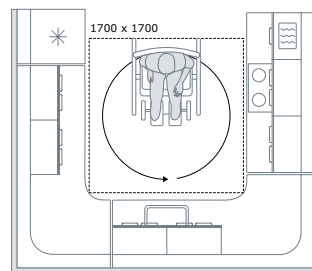

A comfort wheelchair user plus carer need a minimum 2100 x 2100 mm turning area for each workstation in the kitchen.

Leg room under the counter or table top may contribute part of the turning area, reducing the amount of free passage needed.

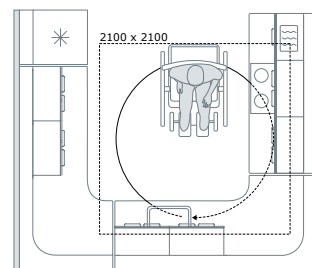
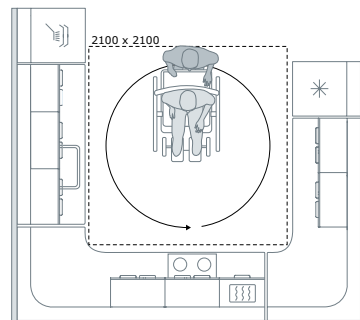

Note: The efficient kitchen must have space for free passage and enough room for wheelchair users to turn in. All measurements are in mm.



Four kitchen models

- using the work triangle

The type of kitchen to choose depends on the kitchen user's physical capacity. The work triangle tells us the most important distances in the kitchen.

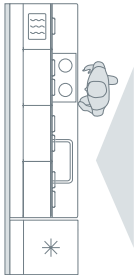

Work triangle in the linear kitchen

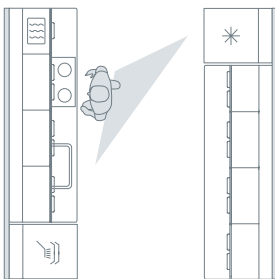

Work triangle in the double linear kitchen

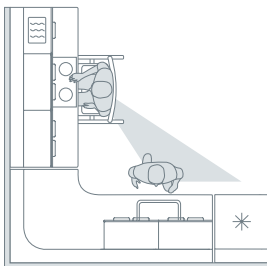

Work triangle in the L-shaped kitchen

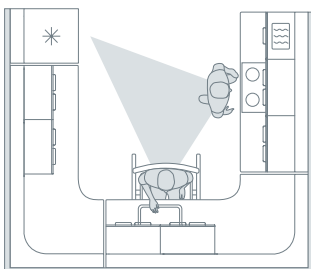

Work triangle in the U-shaped kitchen

The work triangle

The work triangle is a tool used in determining the appropriateness of a particular kitchen design. It is constructed by connecting up the central points of the sink, the hob, and the refrigerator so they form a triangle. Then we determine the circumference of that triangle, which gives us the total work distance in the kitchen.

As a rule of thumb, the total distance between sink, hob and refrigerator should be somewhere within 3600-6600 mm. The distance between sink and hob should be 1200-2000 mm. And the work triangle as such should not be crossed by any line of traffic.

Linear kitchen

Linear kitchen design is unsuitable for wheelchair users, as the distances between workstations are too great. This kitchen model is not practical when several persons need to work there at the same time.

The linear kitchen is often chosen where the available space is small, and when the kitchen does not have a very high priority - for example in sheltered housing where food is delivered or where food is eaten in a communal dining room.

Double linear (parallel) kitchen

This design is not suitable for wheelchair users and the walking-impaired because food and cooking utensils must be moved from one working top to the other.

The double linear kitchen is often used where the kitchen has a door at both ends, and is not recommended for anyone with a physical disability. Kitchen designs with islands should also be avoided.

The L-shape

The L-shaped kitchen is suitable for both wheelchair users and for those who have difficulty walking, because the triangular arrangement provides continuity between the individual workstations. Food and cooking utensils can be moved across the countertop, thus avoiding lifting.

The L-shaped design is used, for example, in large kitchens where more than one person may be working in the kitchen at once.

The U-shape

The U-shaped kitchen provides good connectivity where there is a need for extra workstations. This arrangement shortens distances and concentrates workstations. The food and cooking utensils can be drawn across the counter to avoid lifting.

The U-shaped installation is used, for example, in large kitchens where more than one person may be working in the kitchen at once.

Note: The work triangle has been developed with respect to the needs of one user.

Location of workstations

- washing-up, food preparation and cooking areas

The size of a kitchen is not the only thing that makes it functional. Functionality also depends on the concentration of the work stations, on minimal distances between them, and on the surface area that is available. All of that takes good planning.

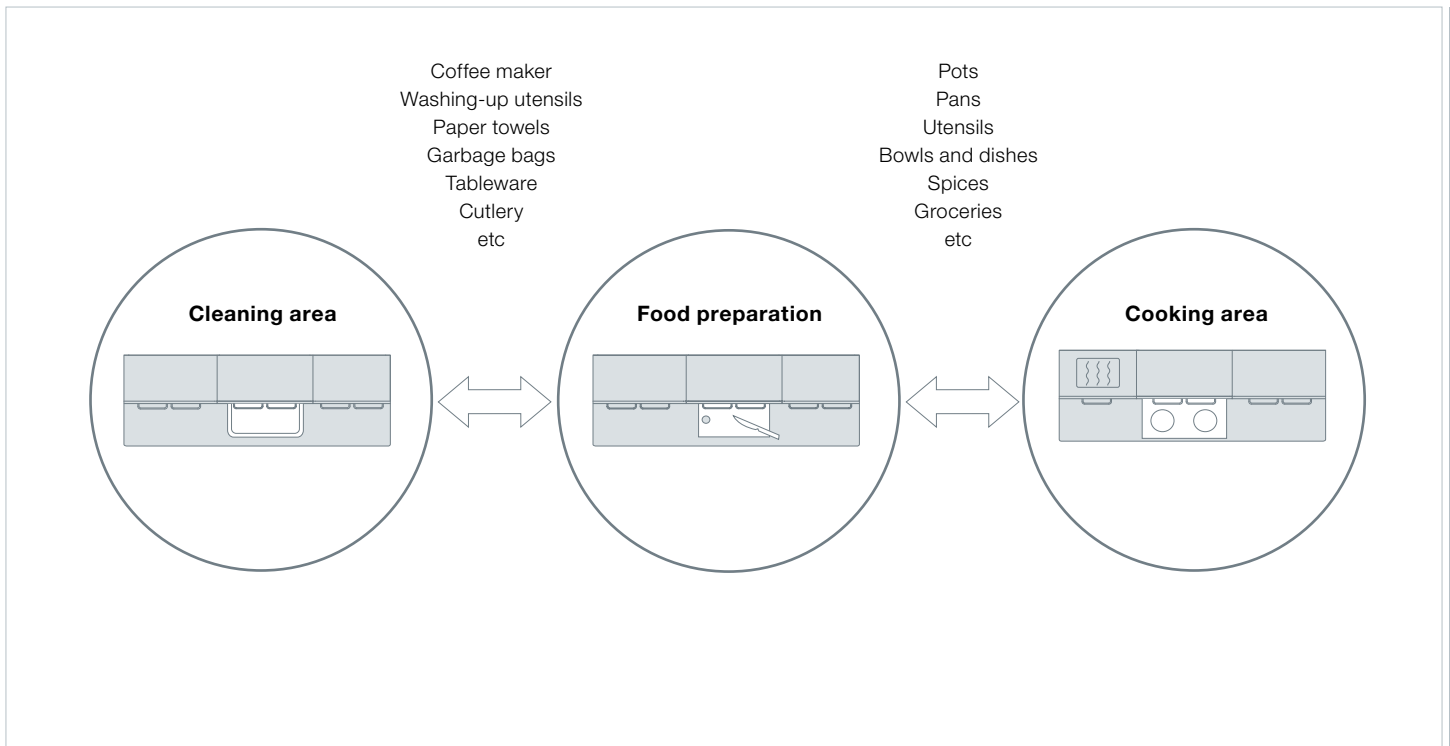

As a rule kitchens must allow for the following types of work:
Cleaning, preparation and blending of food, cooking on a hob or in the oven, and subsequent cleaning/washing-up.

The most important workstations in the kitchen are:

- The washing-up area**
- The food preparation area**
- The cooking area**

Each workstation must have storage facilities to ensure rapid and simple access to food and utensils.

The food preparation centre is usually located between the sink and the hob for easy access to cleaning and food preparation.

The sequence - washing-up, preparation, cooking areas - can be reversed. On the following pages we describe three workstations and how they are related.

Note: It is essential to be able to adjust the height of the workstations to the needs of standing and seated users. It is also important to have leg room here. All measurements are in mm.



The cleaning area

- *preparation, storage and waste*

Work carried out in the washing-up area is closely related to the food preparation area, storage facilities, and waste handling. The washing-up area should be either to the right or left of the central food preparation area.



Washing-up area and storage space

There must be room to store dishwashing utensils, garbage bags, tableware and cutlery in drawers or cupboards close to the sink. Cutlery may e.g. be placed in a holder on the work top.

Washing-up area and preparation

There should be work tops on both sides of the sink on which to place tableware and kitchen utensils. This also ensures good hygiene when preparing various types of food.

Washing-up area and garbage disposal

There should be easy access to garbage disposal at the sink. Garbage containers should be located close to the sink, e.g. in a mobile storage unit.

Washing-up area and dishwasher

A dishwasher eases work loads and should be installed. There must be a work surface nearby to load and unload the dishes.



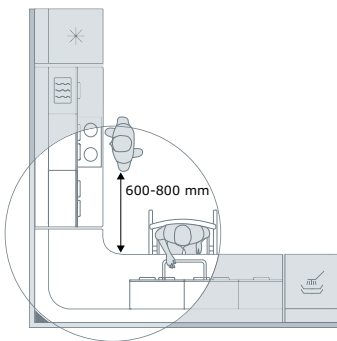
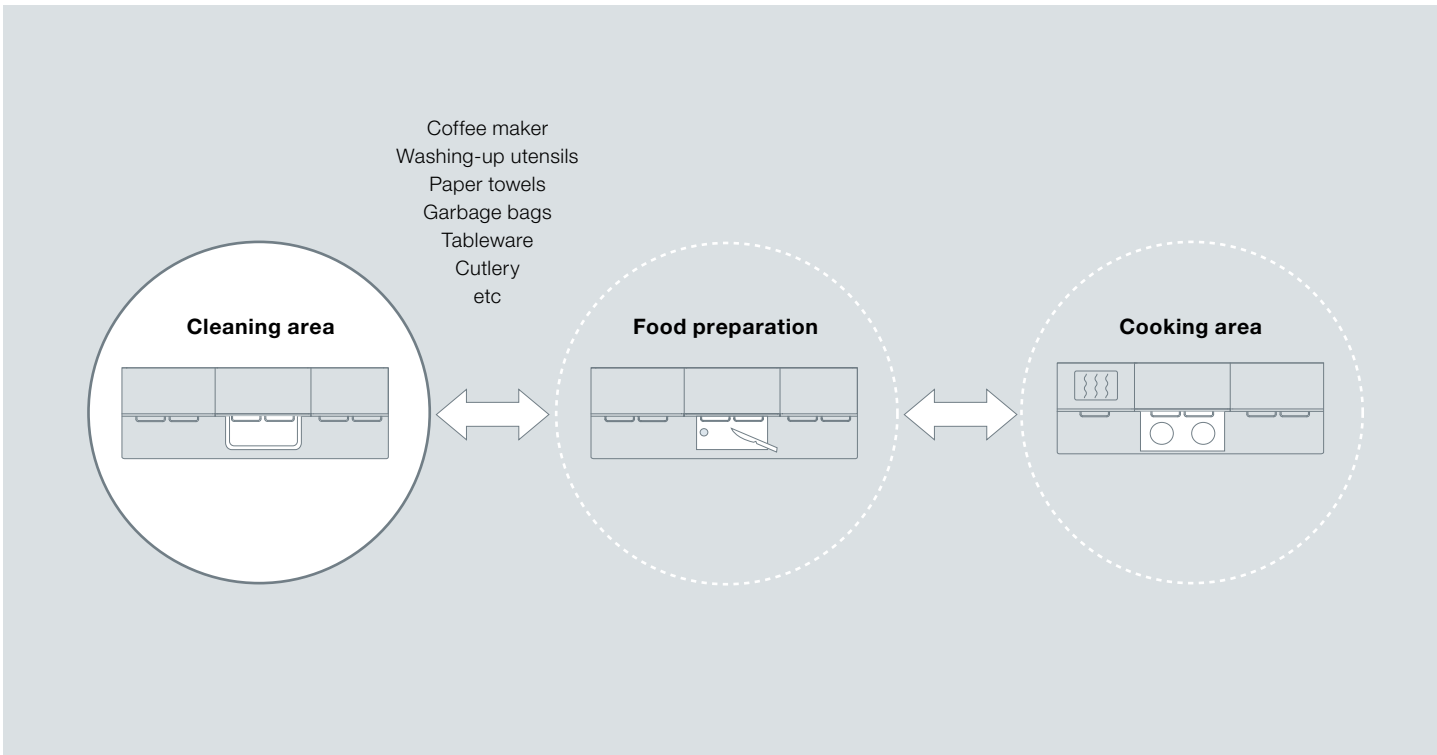

Corner layout – work space

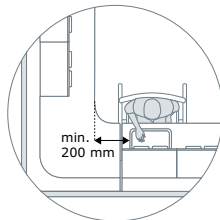

Sink – min. 200 mm from a corner

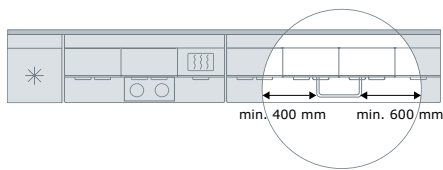

Space on both sides of the sink

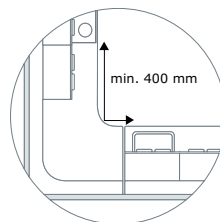

Utilization of the corner space

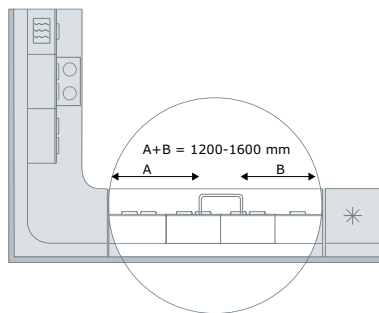

Ideal space for utensils

Spatial requirements

Distances between the cleaning area, storage areas and garbage container should generally be short in order to minimize transport distances.

Work space for various persons

In L- or U-shaped layouts working areas must be located 600-800 mm from the corner. This ensures that 2 users can work comfortably without getting in each other's way.

The sink should be positioned min. 200 mm from a corner. This ensures that there is enough room for a sitting or standing user to be able to work comfortably.

Minimum space for utensils

Regardless of the kitchen is singled-sided, L- or U-shaped, there must be space on both sides of the sink: min. 600 mm on one side and min. 400 mm on the other side for kitchen utensils. A corner space may be useful to ensure a minimum of 400 mm.

Ideal distances when preparing food for several persons

The ideal length (A+B) of the workstation depends on how many people the kitchen serves:

- up to 2 persons: 1200 mm
- up to 4 persons: 1400 mm
- up to 6 persons: 1600 mm

Note: Spatial requirements for users – please see page 8.



The food preparation area

- storage, washing-up, cooker, oven

Work done in the food preparation area is closely related to the washing-up area, waste handling, storage facilities, hob and oven. To keep it all together, this workstation should be between the cleaning and cooking areas.



Food preparation area and storage

Tableware, cutlery, utensils, bags, and other materials in daily use should be stored in a cupboard or drawers near the food preparation area.

Dishes and bowls for use in preparing and serving food should be within a comfortable reaching distance and height. In large kitchens, the kitchen machines and refrigerator should be located close to the food preparation area.



Food preparation area, sink and waste

There should only be a short distance from where food is stored to where it can be rinsed at the sink - as with vegetables - and then to waste disposal. And the dishwasher should also be easily accessible from here.

A pull-out work top is useful as an extra sandwich-making/food preparation area or as a dining area in a small kitchen.

Food preparation area, hob and oven

Once prepared, food is filled into pots, pans or dishes. These and the cooking utensils used at the hob should be located nearby.

It should be possible to keep an area clear to push food from the preparation area to the cooking area, thereby avoiding heavy and straining lifting.

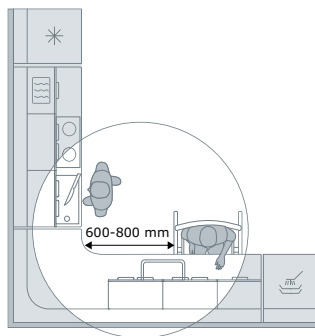
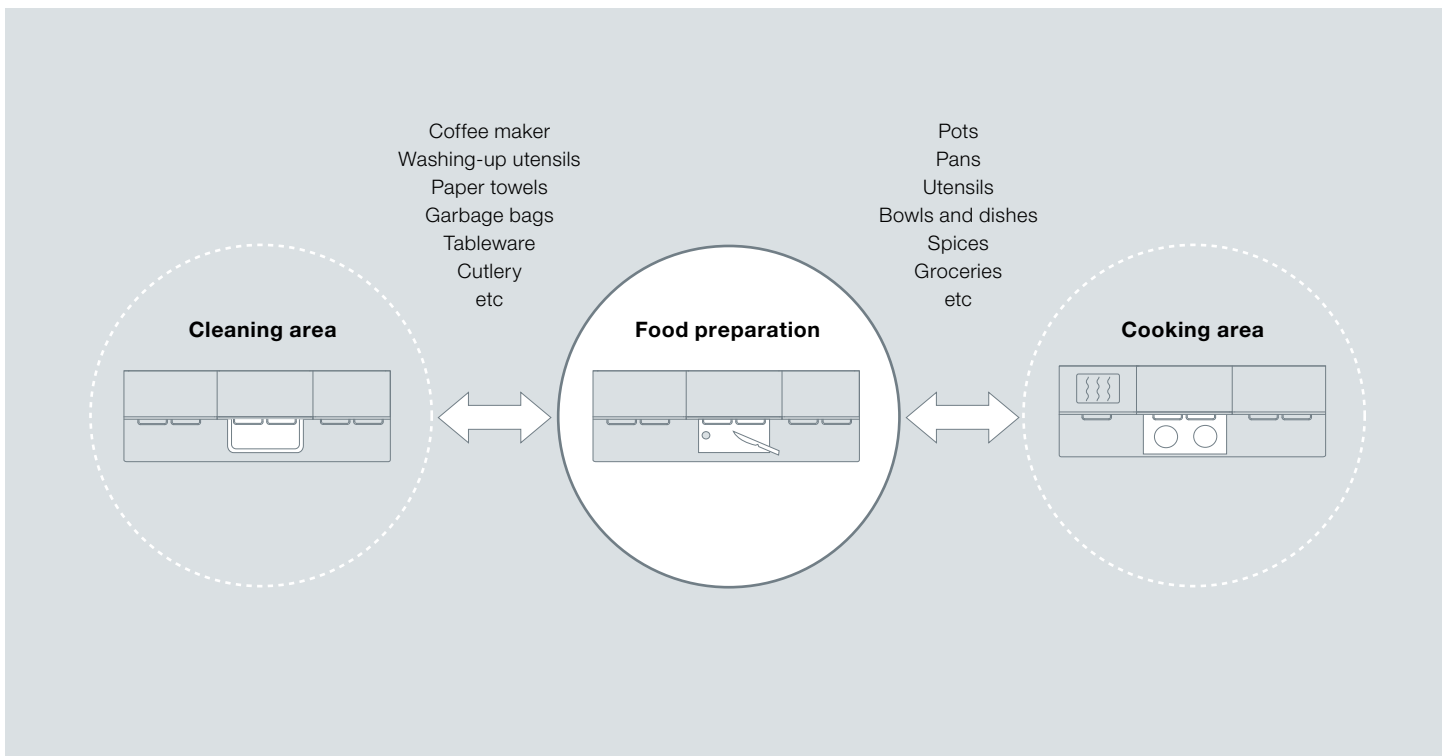

Corner layout – space for work

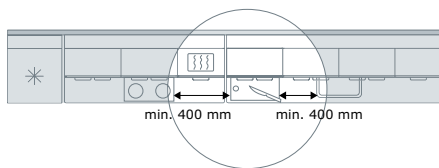

Space on both sides of the food preparation

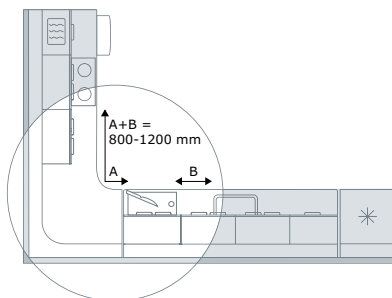

Ideal space for utensils

Spatial requirements

Distances between the food preparation area, storage, sink and waste container, as well as the range and oven should generally be short in order to minimize transport distances.

Work space for various persons

In L- or U-shaped layouts working areas must be located 600-800 mm from the corner. This ensures that 2 users can work comfortably without getting in each other's way.

Minimum space for utensils

There should be min. 400 mm of space on either side of the area used for food preparation.

Ideal distances when preparing food for several persons

The ideal length of the workstation depends on how many people the kitchen serves:

- up to 2 persons: 800 mm
- up to 4 persons: 1000 mm
- up to 6 persons: 1200 mm

There may be several preparation areas in the kitchen, e.g. in the form of extension and pull-out work tops.

Note: Spatial requirements for users – please see page 8.



The cooking area

- storage, preparation, cleaning

Work done in the cooking area is closely related to the storage facilities, the food preparation area and the cleaning area.

This workstation should be to the left or right of the central food preparation area.



Cooking area and storage

Pots, pans and ovenproof dishes are used in the cooking area. Utensils, groceries and spices should be stored in adjustable-height wall cupboards, mobile storage units or on the worktop near the hob.

Cooking area and food preparation

To one side of the cooking hob there should be a preparation area, and on the other side a heatproof area to set down hot pans (on heat-resistant plates or mats). The hob and the oven should be installed as 2 separate elements to keep leg room for working while seated.

Cooking area and sink

The distance from cooking area to sink should be short, and it should be possible to keep a clear push and pull area, so as, for example, to facilitate the filling of pots with water or the pouring of hot water into the sink.

In large kitchens it is advantageous to have an extra tap and drain directly next to the cooking area. A handheld mixer fitting with a spray head and extendable hose is very useful.



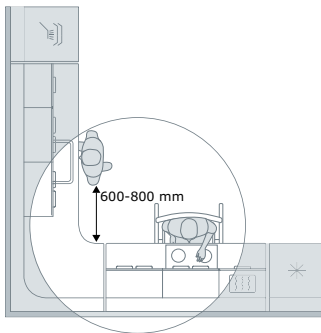
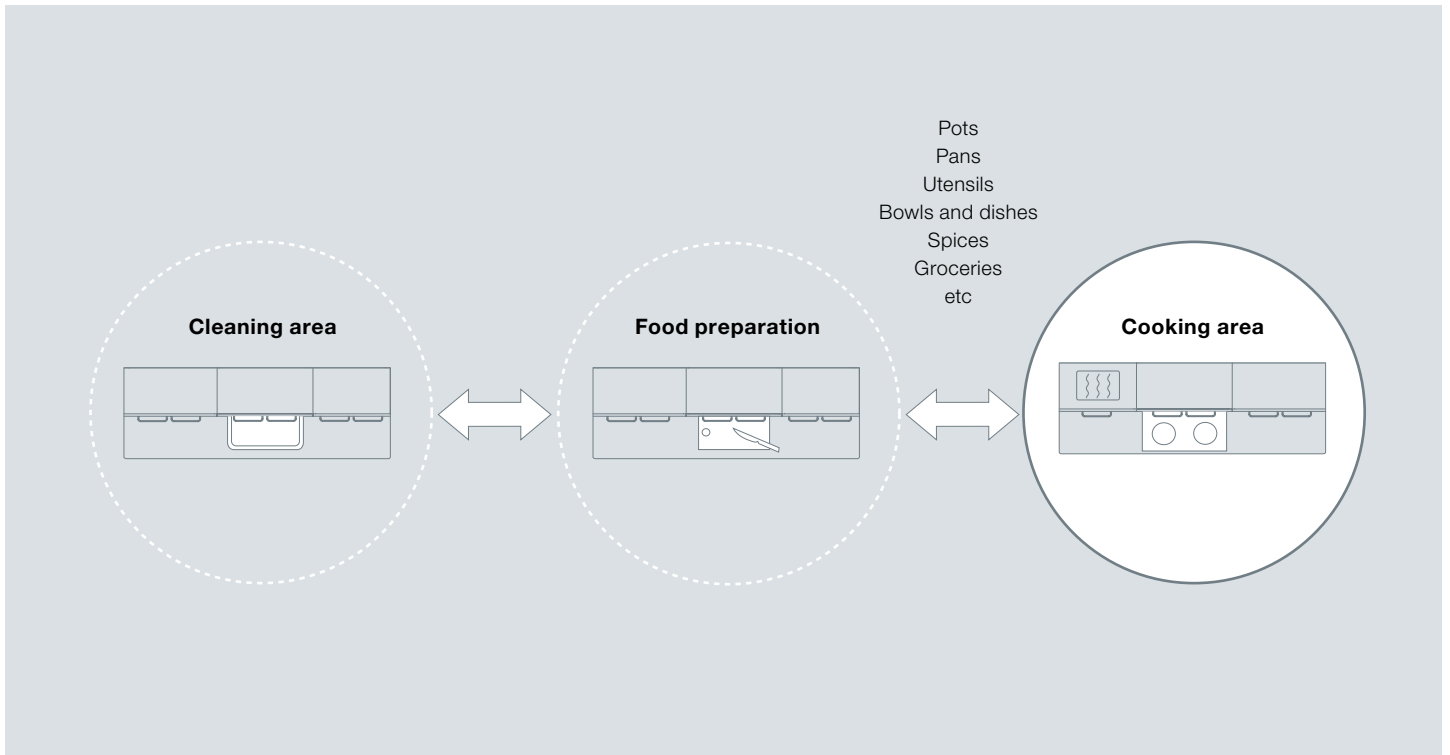

Corner layout – work space

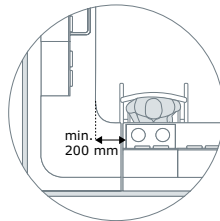

Hob – min. 200 mm from a corner

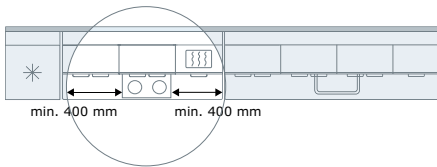

Space on both sides of the hob

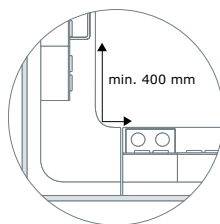

Utilization of the corner space

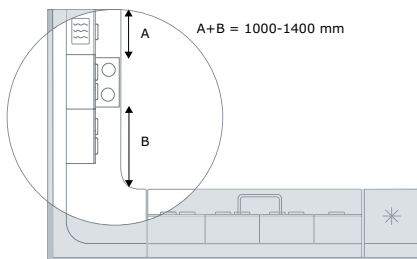

Ideal space for utensils

Spatial requirement

Distances between the cooking area, the food preparation area, storage and sink should generally be short in order to minimize transport distances.

Work space for various persons

In L- or U-shaped layouts working areas must be located 600-800 mm from the corner. This ensures that 2 users can work comfortably without getting in each other's way.

The cooking range should be positioned min. 200 mm from a corner. This ensures that there is enough room for a sitting or standing user to be able to work comfortably.

Minimum space for utensils

Regardless of the kitchen is singled-sided, L- or U-shaped, there must be space on both sides of the cooking installation: min. 400 mm.

The space in a corner can be utilised to good effect.

Ideal distances when preparing food for several persons

The ideal length (A+B) of the workstation depends on how many people the kitchen serves:

- up to 2 persons: 1000 mm
- up to 4 persons: 1200 mm
- up to 6 persons: 1400 mm

Note: Spatial requirements for users – please see page 8.



Storage

- *an overview*

It is vital to the accessibility of a kitchen that food and utensils are placed close by the work stations where they will be used. There should be drawers, bins, shelves and table space for storage at each work station.



The ideal storage capacity

How much storage space is needed depends on how many people the kitchen serves:

- up to 3 persons: 7800 mm shelves/drawers
- up to 6 persons: 10200 mm shelves/drawers

Note: The height-adjustable kitchen should preferably be designed without cupboards under the work tops in order to free up leg room. But this reduces storage area, so not all kitchens will comply with the above general recommendations.

Storage next to the washing-up area

The following should be stored near the sink:

- Tableware and cutlery in daily use.
- Waste containers, cleaning agents and utensils may be stored e.g. in a mobile storage unit.

Dishes and utensils that are not used daily can sometimes be stored in a different room.

Storage at the food preparation place

The following should be stored close by:

- Utensils, food and packaging, for example in an adjustable-height overhead cupboard.
- Kitchen appliances in everyday use, e.g. on the work top or in available cupboard space.

Storage by the hob

The following should be stored here:

- Cooking and baking utensils, etc, e.g. in a mobile storage unit.

Storage in the refrigerator or freezer

Chilled and frozen food go in the refrigerator, frost box or freezer.

A freezer is ideal for anyone who cannot get out to buy groceries so often.



Note: The abovementioned ideal storage capacity covers dining and preparation utensils, grocery, stockpile etc. It is ideal to ensure short distance from dining area to storage of utensils.

White goods

- ovens, cookers, ventilator hoods, refrigerators and dishwashers

White goods should be selected based on the primary user's needs and capacity, so these recommendations are only of a general nature.



Ovens

- We recommend tabletop or built-in models with side-hinged doors.
- If possible they should be placed near the refrigerator so refrigerated or frozen goods can be moved easily to the oven.
- Place at eye level, about 1200-1630 mm high, so users can see into the oven.
- Adjustable height facilitates the removal of warm food from the oven at a comfortable height.

Cookers and ventilator hoods

- Having the hob separate from the baking oven provides leg room for users who are seated.
- Ceramic or induction hotplates with touch panels should be chosen for persons with reduced movement in fingers and arms.
- Electric hot plates with knobs are best for persons with impaired vision.
- The number of hot plates depends on how often food is prepared in the kitchen.
- Heat insulation on the underside of the hob is a necessity to prevent burns to the legs and knees.
- There should be heat resistant surfaces close to the hob for the temporary placing of hot pots and pans.
- The ventilator hood should have two separate buttons for exhaust fan and light, placed in the front.

Refrigerator

- A model with frost box should be chosen if there is no room for a freezer.
- Automatic defrosting should be a standard feature.
- Transparent pull-out shelves and baskets make it easier to see what is in them.
- The refrigerator door should open to 180°.
- Place the refrigerator a minimum of 300 mm above floor level.

Dishwasher

- Place it close to the sink and drain, min. 300 mm above floor level; or choose a table top model.
- Free space in front of the dishwasher so open doors do not restrict passage.



Sink and mixer taps

Improved accessibility is often in the details. That is why it is so important to pay attention to the sink and mixer taps, safety arrangements, handles, etc when planning and installing a new kitchen.



Sink

There should be legroom under the sink to facilitate working comfort in the seated position.

Location:

- As far towards the front of the work top as possible.

Shape:

- Low depth: 100-120 mm to provide room for the thighs and knees of seated users. Depths of 150 mm can be used for standing users.
- Width: min. 450 mm.

Other comments:

- Siphons and drains should be mounted as far back towards the wall as possible.
- Siphons and drains should be insulated to avoid burns to legs and feet.
- The underside of the sink should be insulated to avoid injuries to the legs of seated users.

Mixer taps

Location:

- The sink mixer tap should be placed within comfortable reach.
- Alternatively, mixer taps may be mounted on walls. This facilitates cleaning, but should be avoided if the user's reach is limited.

Other comments:

- It is of benefit to use single-handed mixer taps with long operating arms for persons with limited reach or strength.
- The spout on the mixer tap should be at the right height and capable of pivoting over a pot placed on the work top. A mixer tap with an extendable and flexible hose may be advantageous.
- Temperature selection and water quantities should be clearly visible on the mixer tap's design.



Essential details

- safety, pull-out work space, handles, lids, fittings, plugs, switches and lighting



Safety

Adjustable-height table tops, cupboards, etc are fitted with a safety mechanism that stops them when they meet resistance, such as for example the legs of a wheelchair user, a kitchen appliance or equipment on the table top.

There must be a safety distance of at least 25 mm from table top to the wall when it is mounted in a corner or between table top sections mounted in extension to each other.

- Hobs and sinks must be insulated underneath to prevent burns to knees and thighs.
- Installations and pipes must also be insulated and covered to prevent burns to knees and feet.

Pull-out work tops

- Provide extra space e.g. by refrigerators and ovens.
- They also provide extra work space in a small kitchen.

Handles, cupboard doors and fittings

- Bracket handles on cupboard doors are light and easy to operate.
- Cupboard doors should be no wider than 300 mm, so as not to take up too much space in the room when they are open. Hinges must open 180°. Alternatively, sliding doors may be used.
- The shelves should be approx. 300 mm deep.
- Drawer fittings with full extension and automatic closing.

Switches, plugs and lighting

- There should be adequate all round lighting in the kitchen and at the individual workstations.
- Plugs for fixed kitchen appliances (coffee machines, etc) should be placed on the rear wall. Plugs for small appliances should be within comfortable reach.
- For aesthetic and safety reasons, wiring should be sunk in the wall, or concealed behind kitchen inventory.
- Electrical wiring and installations must comply with national statutory requirements.



Comfort zones

Comfort zones refer to general reach and height measurements, within which by far the majority of users can work comfortably. In the accessible kitchen, as many features as possible should be located within the comfort zones.

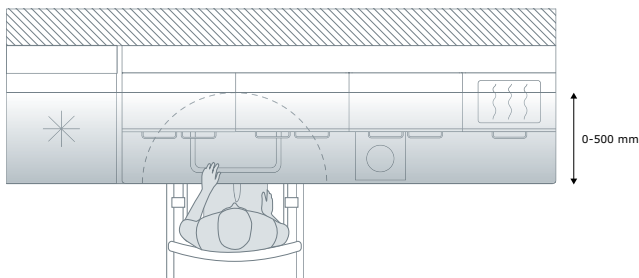

Comfortable reach

Comfort zones – comfortable reach

Comfortable reach:

0-500 mm from front edge of the table top.

Depending on the user's physical capacities, it can be difficult to reach the food and utensils that are at the back of the table.

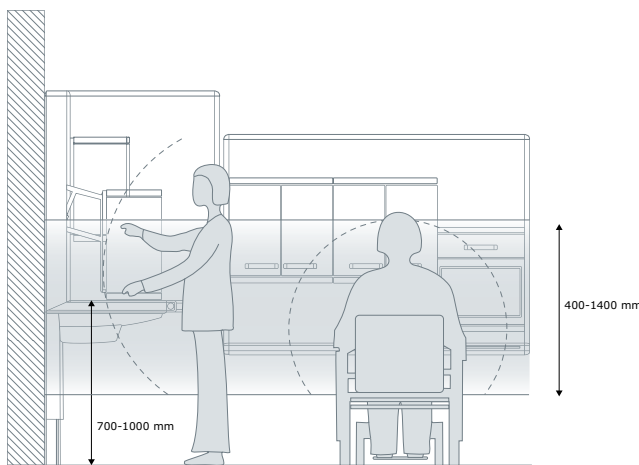

Comfortable working height and reach

Comfort zones – comfortable working height and reach

Comfortable working height:

700-1000 mm over floor level.

Comfortable reach:

400-1400 mm over floor level.

Our knowledge of general comfortable reach and working height, i.e. of comfort zones, is based on surveys among disabled users.

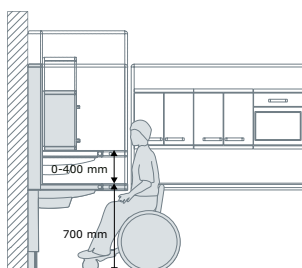

Height adjustment of table top and cupboards

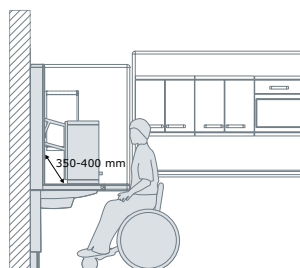

Height adjustment of overhead cupboards

Height adjustment of table tops and cupboards

Table tops are normally adjusted to a height of 700 mm over floor level, and it should be possible to raise them to as high as 1000 mm.

Separate height adjustment of overhead cupboards

Overhead cupboards are mounted about 350-400 mm over the work top. They can be lowered to the level of the work top and also pulled forward to the front edge.

Height adjustment

Correct worktop height is important to whether the kitchen is designed appropriately for the user. It is essential that work surfaces can be height-adjusted to light or heavy work. It should also be possible to adjust cupboard heights and white goods should be placed at a comfortable height.

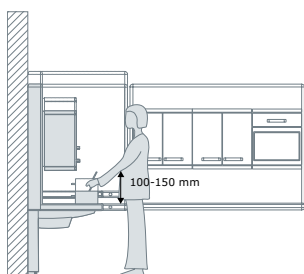

Light work

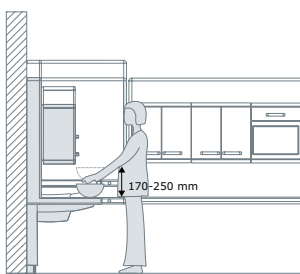

Heavy work

Comfortable height: light and heavy work

Table tops are set to a default height suitable for light work, such as stirring a pot, which is approx. 100-150 mm under elbow height.

For heavy work, such as kneading dough, it is reasonable to work at a lower table height, from 170-250 mm under elbow height. The above measurements apply both to standing and seated users.

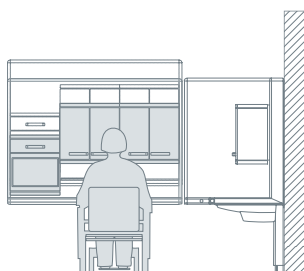

Oven

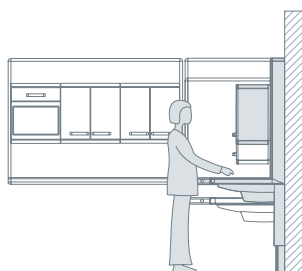

Sink

Adjusting the height of ovens

It should be possible to adjust ovens to an appropriate working height. Some microwave appliances can be built into an adjustable-height overhead cupboard.

Adjusting sink and cooker heights

Sink and hobs are typically built into the worktop and their heights are thus automatically adjusted.

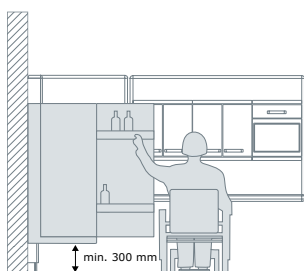

Refrigerator

Location: refrigerator and dishwasher

The refrigerator should be placed so as to provide easy access to most of the shelves from a sitting position. Refrigerators are installed min. 300 mm over floor level.

The appropriate height for dishwashers is at least 300 mm over floor level. Alternatively, a tabletop model may be used.



Kitchen design proposals

- linear kitchen

On this and the next pages we will show how both large and small kitchens can be furnished as linear kitchens or as one of the angular models.

The linear kitchen is the least demanding of all where space is concerned, but it is also the least practical for the kitchen user.

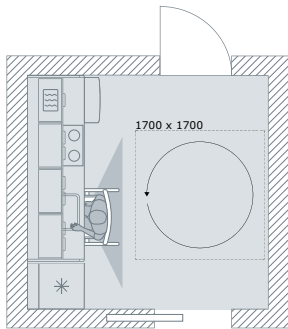

A compact kitchen for one user

The compact kitchen is one that provides the absolute minimum of kitchen facilities. Compact kitchens are often used in apartments and also where the kitchen is not of high priority, for example in sheltered housing or nursing homes where meals are delivered. Often there is through traffic right by the work stations, and often there is no room for a dishwasher.

Kitchen area: 3180 x 3060 mm, total 9.7 m²
Work triangle: 2000+1100+1100 = 4200 mm

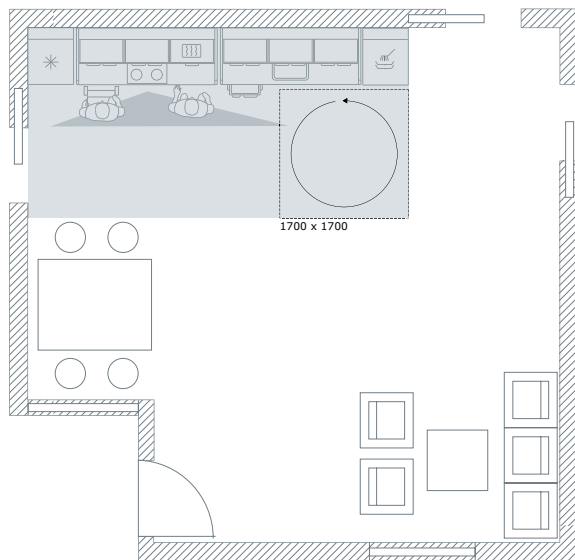

Dayroom kitchen for more users

This type of kitchen can be placed along the wall in a dayroom with combined dining and living room space.

The refrigerator and dishwasher can be placed at the end of the height adjustable table top modules. An alternative would also be to have a tabletop dishwasher model.

Kitchen area: 5040 x 2520 mm, total 12.7 m²
Work triangle: 3000+1700+1300 = 6000 mm

Note: The model proposals can also be installed in other rooms than those listed here, and the sequence of modules may be reversed. The kitchen areas given here do not include dining area. All measurements are in mm.

Kitchen design proposals

- L-shaped kitchen

The L-shaped kitchen is well suited for one or several users and provides excellent working conditions for standing as well as seated users.

The L-kitchen, together with the U-kitchen is the best layout when several persons will be working in the kitchen at the same time.

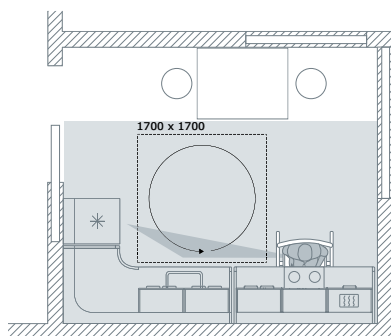

Kitchen for one user

The L-kitchen provides good continuity between the different workstations, and is well suited for installation in private homes.

Kitchen area: 2640 x 4140 mm, total 10.9 m²
Work triangle: 2800+1500+800 = 5100 mm

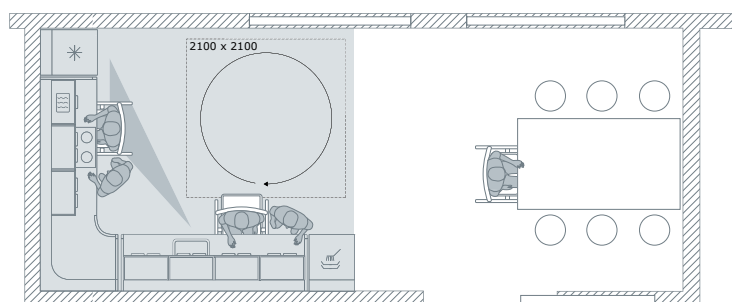

Kitchen for several users and carers

The L-kitchen is suitable when more than one user will be working in the kitchen, for example in training kitchens. There is also room for the carer to provide information and support in the work process.

This kitchen should include at least two individually adjustable table tops and adjustable wall cupboards.

Kitchen area: 4260 x 3480 mm, total 14.8 m²
Work triangle: 1200+2400+1400 = 5000 mm

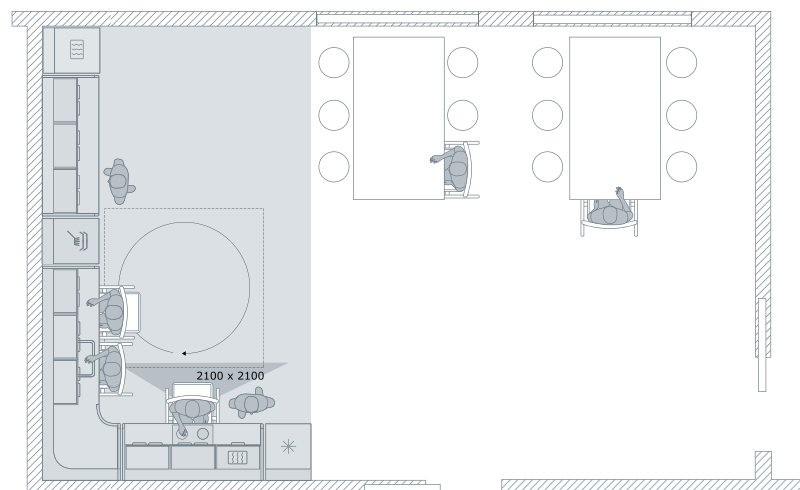

Kitchen for several independent users

The L-kitchen is a good choice when room is needed in the kitchen for several users to all work there at once, for example in sheltered residential institutions.

The kitchen should be installed with an adequate number of individually height adjustable table tops and height adjustable wall cupboards.

Kitchen area: 3540 x 6000 mm, total 21.2 m²
Work triangle: 2200+1500+1100 = 4800 mm

Note: The model proposals can also be installed in other rooms than those listed here, and the sequence of modules may be reversed. The kitchen areas given here do not include dining area. All measurements are in mm.



Kitchen design proposals

- U-shaped kitchen

The U-shaped kitchen shortens distances and concentrates workstations. It is well suited for large kitchens where there is a need for several individually height adjustable sections, and a need for plentiful storage space and numerous work stations for food preparation.

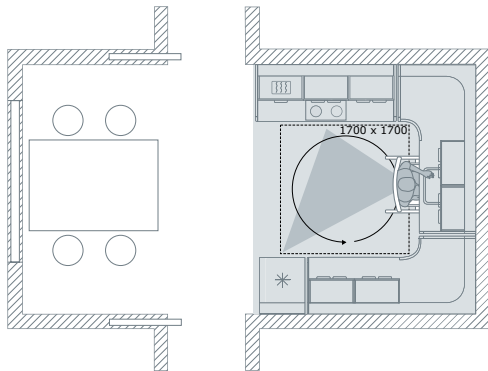

A kitchen for one user

The U-kitchen provides good continuity between workstations and can also be used very well in private homes.

Kitchen area: 3300 x 2940 mm, total 9.7 m²
 Work triangle: 1300+1800+1200 = 4300 mm

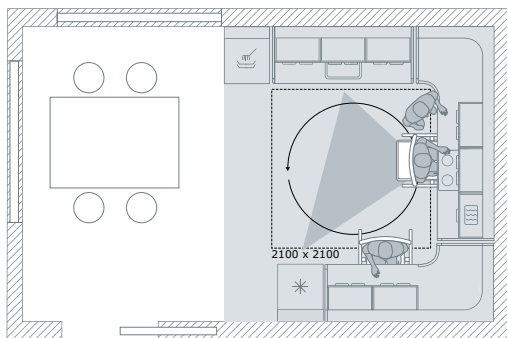

Kitchen for several users and carers

The U-kitchen is suitable when more than one user will be working in the kitchen, for example in training kitchens. There is also room for the carer to provide information and support in the work process.

This kitchen should include at least two individually adjustable table tops and adjustable wall cupboards.

Kitchen area: 3540 x 3900 mm, total 13.8 m²
 Work triangle: 2000+1700+1200 = 4900 mm

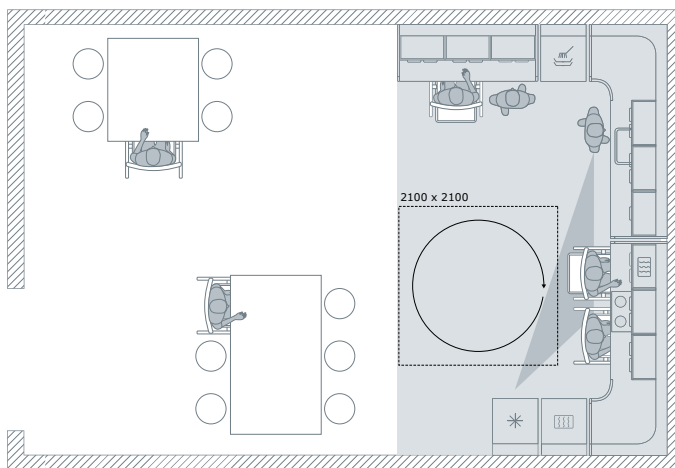

Kitchen for several independent users

The U-kitchen is a good choice when room is needed in the kitchen for several users to all work there at once, for example in sheltered residential institutions.

The kitchen should be installed with an adequate number of individually height adjustable table tops and height adjustable wall cupboards.

Kitchen area: 3540 x 5700 mm, total 20.2 m²
 Work triangle: 3200+2000+1400 = 6600 mm

Note: The model proposals can also be installed in other rooms than those listed here, and the sequence of modules may be reversed. The kitchen areas given here do not include dining area. All measurements are in mm.

Checklist

You are welcome to use this checklist during the planning phase to help keep all of the essential factors in mind that go into the makings of an efficient and accessible kitchen.

Users and carers

- Are we planning for one particular or for many users?
- Who are the users? What mobility aids do they have?
- Is training and/or rehabilitation included?
- What level of everyday workplace skills do the users have?
- What work is to be performed?

Type of housing or institution

- Hospitals, rehabilitation centres, nursing homes, special institutions, senior facilities, sheltered housing for the elderly?
- Private homes, residential institutions, hotels and holiday complexes?

The room

- Is this a new project or a conversion?
- How large is the room and what is its shape?
- Are there any architectural or structural elements – installations, columns, doors – that need to be taken into consideration?
- Does the room fulfil the current regulations and norms for the furnishings of kitchens for disabled persons?
- Is the floor area sufficient for wheelchair users to be able to turn?
- Is there enough free space and passageway in front of the kitchen elements and appliances – and is the space around the workstations free of traffic?
- Will it be possible to provide enough leg room at the cleaning, food preparation, and cooking workstations?

Work tops

- Can the height of work surfaces be adjusted individually?
- Are there uninterrupted push and pull surfaces between the workplaces?
- Is there work top room on both sides of the sink and cooker?

Cupboards

- Are cupboard doors max. 300 mm wide, and do they open 180°?
- Are there any mobile storage units already?
- Is there enough storage space at the various workstations?
- Do the cupboards have user-friendly handles?

White goods

- Is the hob separate from the oven, and is there a ventilator hood?
- Is there a tabletop oven or can oven height be adjusted?
- Are the doors to the oven hinged on the sides, and is there a pull-out board under the oven?
- Can the dishwasher be placed at an accessible height?
- Is the refrigerator placed at an accessible height?
- Are most of the refrigerator shelves placed at an accessible height?

Essential details

- Is the sink depth suited to seated users, i.e. 100-120 mm?
- Are the siphon and drain pipe mounted as far back against the wall as possible?
- Is there a tap and drain somewhere near the hob?
- Are the undersides of the sink and the hotplates on the hob insulated, and are the water pipes and installations insulated and covered to prevent the risk of burns?
- Can the mixer tap be turned off and on with only one hand and can the arm of the tap be swung to the side?
- Are there safety mechanisms to prevent crushing injuries?
- Are there enough electric sockets at accessible heights and is the lighting sufficient?

PRESSALIT®

*Reduced functionality need not limit a person's development.
For more than 35 years, the keep living philosophy has been a
guiding principle for Pressalits development of flexible kitchen and
bathroom solutions for people with disabilities.*

*Thanks to its research-based knowledge, Pressalit is a market
leader within specialist kitchen and bathroom solutions and today
provides consultancy to customers worldwide.*

*An underlying respect for the individual and his or her possibilities
is also reflected in the company's relationship to society at large and
the local community. At Pressalit, Corporate Social Responsibility
(CSR) is deeply rooted in the company's strategy and values and
guides all parts of the organisation.*

Pressalit's head office is located in Denmark.

www.pressalit.com

Pressalit A/S
Pressalitvej 1
8680 Ry
Danmark
Tel.: +45 8788 8788
Fax: +45 8788 8789
pressalit@pressalit.com

Pressalit Limited
100 Longwater Avenue
Green Park
Reading, Berkshire
RG2 6GP
United Kingdom
Tel.: 0118 923 2696
Fax: 0118 986 8867
uk@pressalit.com

PRESSALIT SUPPORTS UNITED NATIONS GLOBAL GOALS AND UNICEF

