

ITEM NO.	PART NUMBER	DESCRIPTION	QTY.
1	006-4006	SHANK #9, PIVOT PIN HYDRAULIC	1
2	006-4015	BUSH ID 35, OD 39, Length 36	2
3	022-3001	SHANK #9, CARRIER RIGID	1
4	022-3009	SHANK #9, TOP CLAMP 200x200	1
5	024-3002	INVERSION SHANK POINT	1
6	024-3004	FABRICATED INVERSION SHANK	1
7	024-4009	SPLITTER PLATES LEFT	1
8	024-4010	SPLITTER PLATES RIGHT	1
9	024-4014	INVERSION SHANK, SPLITTER PLATE, BOLT SHIELD	1
10	133-4114	M20 x 100 HEX BOLT ZINC	4
11	133-4125	M12 x 55 HEX BOLT ZINC	2
12	134-1045	M20 HEX NUT ZINC PLATED	4
13	134-4017	M12 HEX NUT ZINC PLATED	2
14	135-1015	SPRING WASHER M20	4
15	135-3038	SPRING WASHER M12	2
16	135-3040	WASHER FLAT M20	4
17	140-0041	LYNCHPIN 11mm 42mm	2
18	140-4087	ROLL PIN 12mm X 55mm	1
19	141-4012	SHEARPIN & CLIPS, #9	1
20	141-0019	HAIRCLIP	2

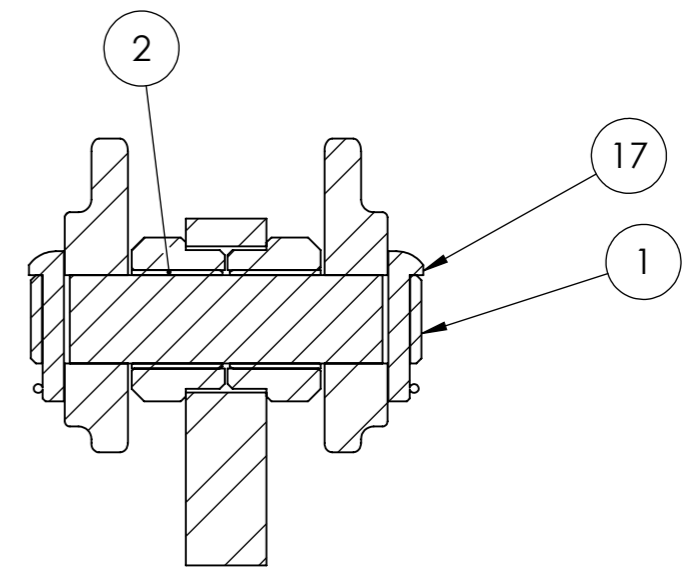
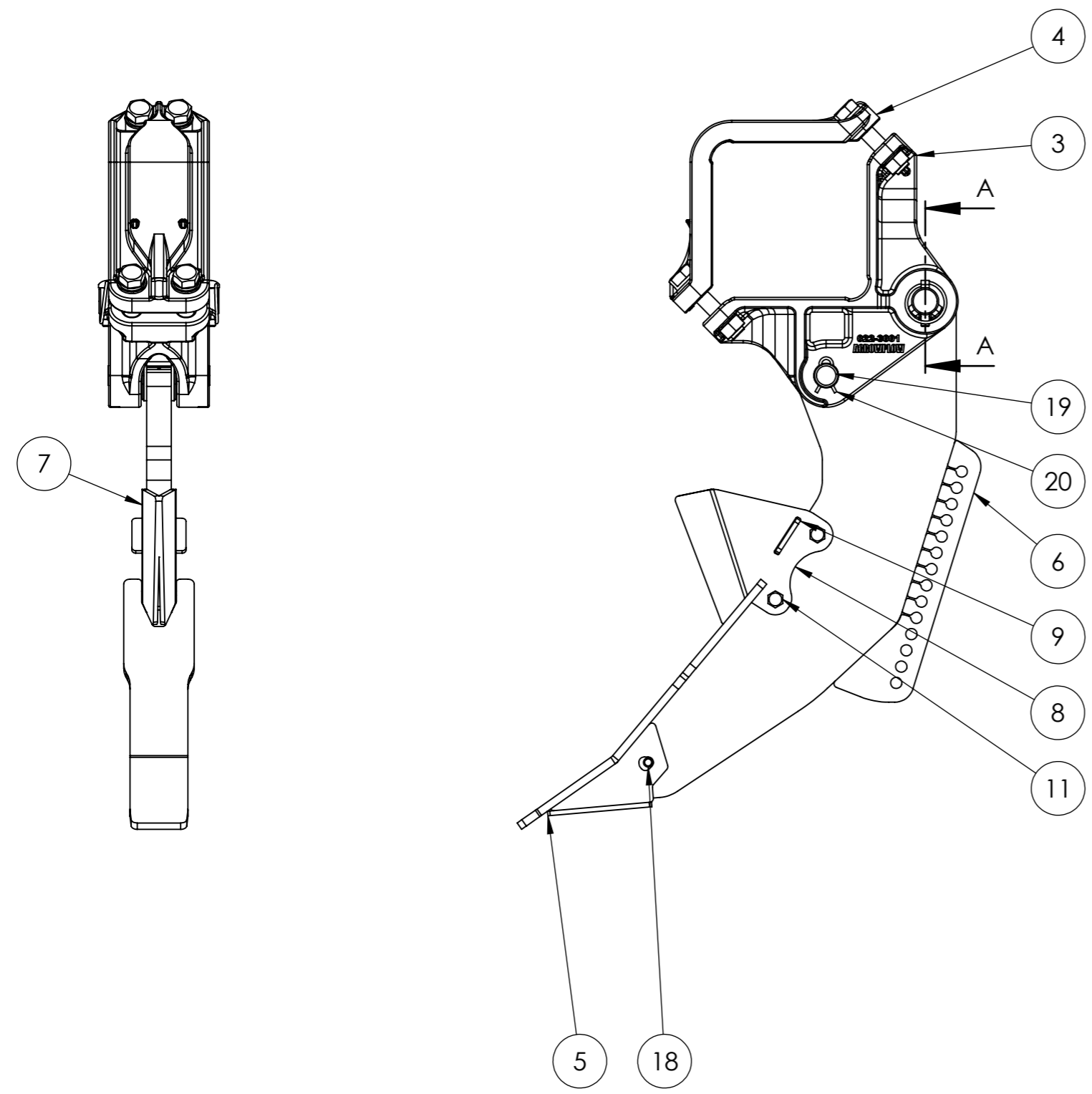

SECTION A-A

INVERSION SHANK TAKES MORE PULLING FORCE TO PULL THROUGH THE GROUND THAN THEN #9 SHANK. THEREFORE WILL RESULT IN HIGHER PULLING FORCE REQUIRED AND/OR THE SHANK ASSEMBLY WILL BREAK OUT AT SHALLOWER WORKING DEPTHS. IF THE INVERSION SHANK IS RECOILED, IT WILL NOT PERFORM CORRECTLY AND CONTINUED USE MAY RESULT IN INCREASED WEAR OR DAMAGE TO THE ASSEMBLY.

<p align="center">AGROWFLOW</p> <p align="center">COPYRIGHT RESERVED</p> <p align="center">THIS DRAWING IS THE PROPERTY AGROWFLOW PTY LTD, AND IS SUBJECT TO RETURN UPON DEMAND. IT IS SUBMITTED FOR USE ONLY IN CONNECTION WITH PROPOSALS OR CONTRACTS OF THIS ORGANISATION UPON THE EXSPRESS CONDITION THAT IT IS NOT TO BE USED DIRECTLY OR INDIRECTLY IN ANY WAY DETRIMENTAL TO THE INTERESTES OF AGROWFLOW PTY LTD.</p>	<p>TITLE:</p> <p align="center">#9 INVERSION SHANK ASSEMBLY 450 RIGID</p>	<p>PART NUMBER</p> <p align="center">024-1001</p>
	<p align="right">17-Feb-17</p>	<p align="center">SHEET:</p> <p align="center">SHEET 1 OF 2</p>

1

2

3

4

5

6

A

A

B

B

C

C

D

D

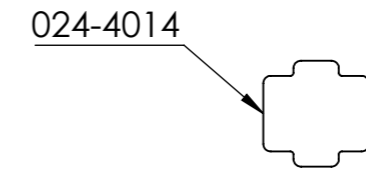
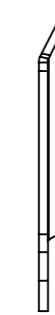
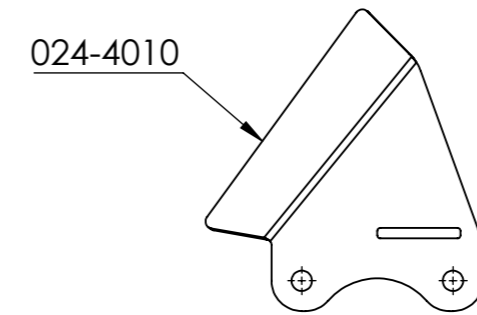
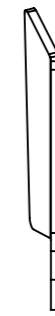
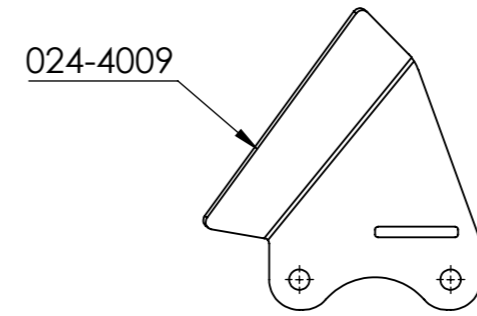
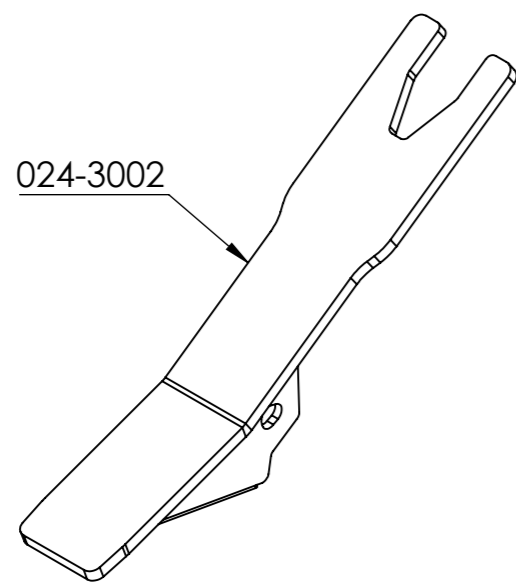
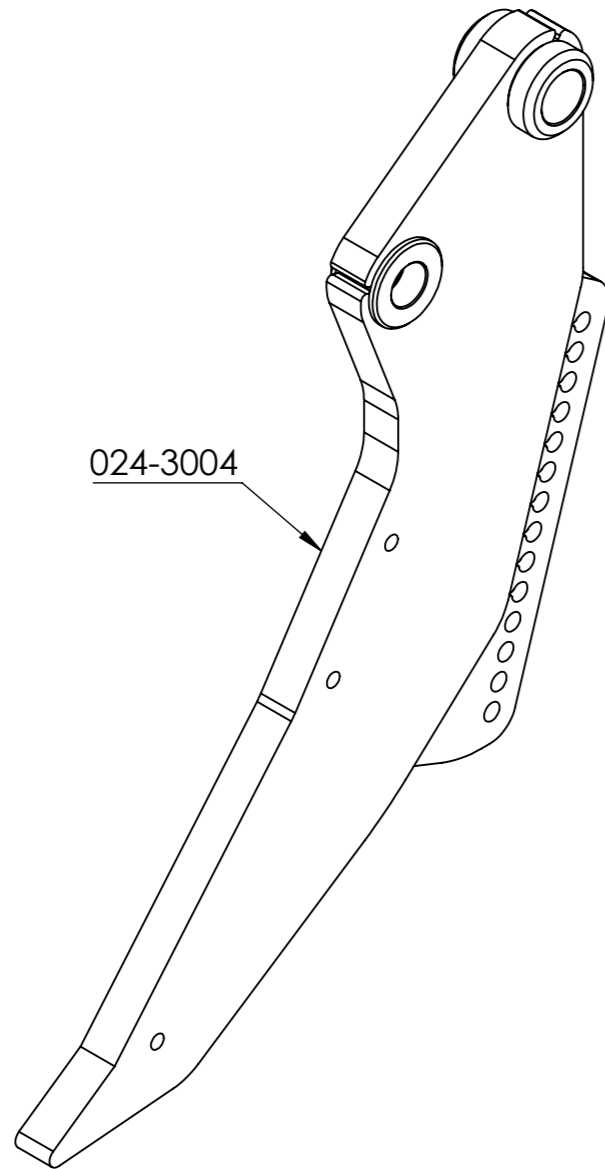

AGROWFLOW		TITLE: #9 INVERSION SHANK ASSEMBLY 450 RIGID	PART NUMBER 024-1001	
COPYRIGHT RESERVED THIS DRAWING IS THE PROPERTY AGROWFLOW PTY LTD, AND IS SUBJECT TO RETURN UPON DEMAND. IT IS SUBMITTED FOR USE ONLY IN CONNECTION WITH PROPOSALS OR CONTRACTS OF THIS ORGANISATION UPON THE EXPRESS CONDITION THAT IT IS NOT TO BE USED DIRECTLY OR INDIRECTLY IN ANY WAY DETRIMENTAL TO THE INTERESTES OF AGROWFLOW PTY LTD.				SHEET: SHEET 2 OF 2
		17-Feb-17		

1

2

3

4

5

6

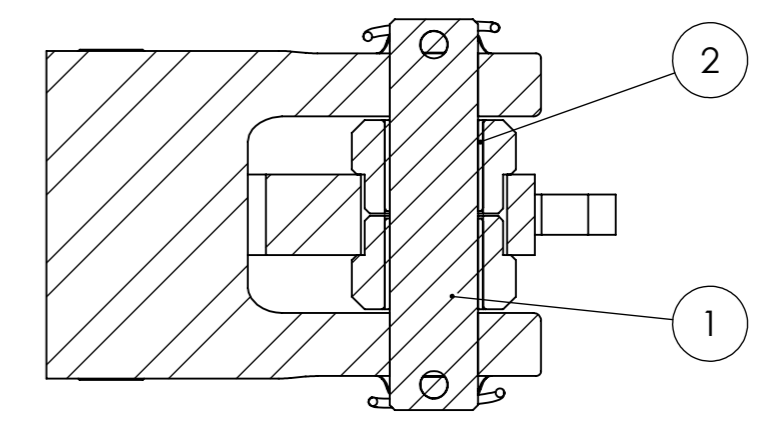
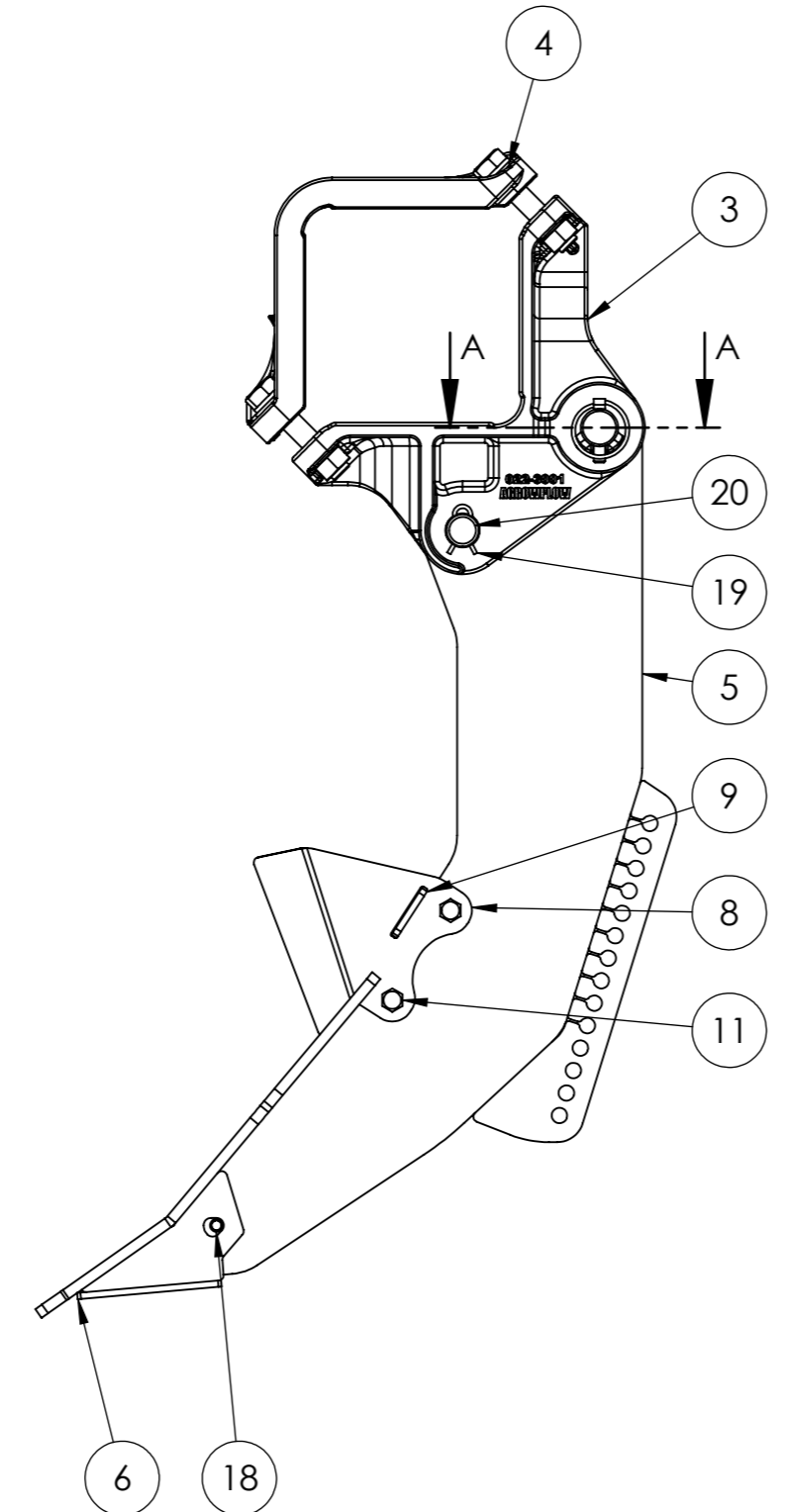
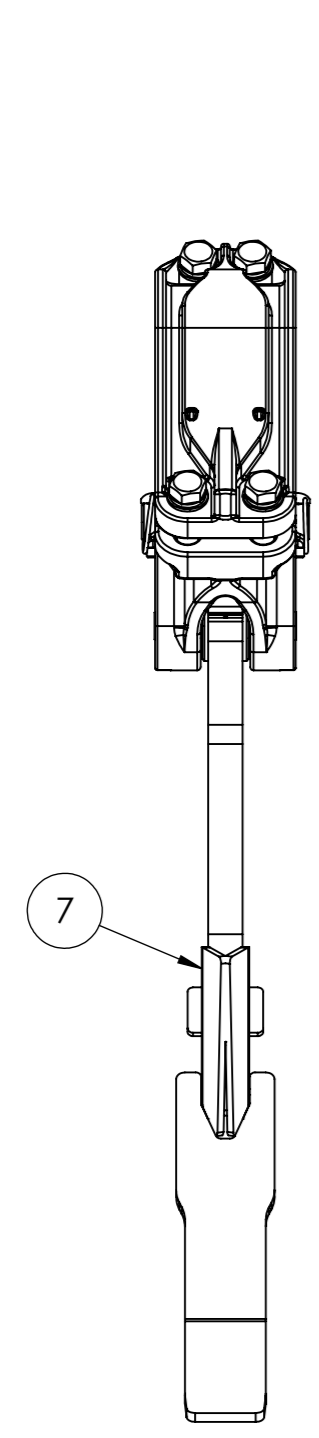

SECTION A-A

ITEM NO.	PART NUMBER	DESCRIPTION	QTY.
1	006-4006	SHANK #9, PIVOT PIN HYDRAULIC	1
2	006-4015	BUSH ID 35, OD 39, Length 36	2
3	022-3001	SHANK #9, CARRIER RIGID	1
4	022-3009	SHANK #9, TOP CLAMP 200x200	1
5	024-3001	FABRICATED INVERSION SHANK	1
6	024-3002	INVERSION SHANK POINT	1
7	024-4009	SPLITTER PLATES LEFT	1
8	024-4010	SPLITTER PLATES RIGHT	1
9	024-4014	INVERSION SHANK, SPLITTER PLATE, BOLT SHIELD	1
10	133-4114	M20 x 100 HEX BOLT ZINC	4
11	133-4125	M12 x 55 HEX BOLT ZINC	2
12	134-1045	M20 HEX NUT ZINC PLATED	4
13	134-4017	M12 HEX NUT ZINC PLATED	2
14	135-1015	SPRING WASHER M20	4
15	135-3038	SPRING WASHER M12	2
16	135-3040	WASHER FLAT M20	4
17	140-0041	LYNCHPIN 11mm 42mm	2
18	140-4087	ROLL PIN 12mm X 55mm	1
19	141-0019	HAIRCLIP	2
20	141-4012	SHEARPIN & CLIPS, #9	1

INVERSION SHANK TAKES MORE PULLING FORCE TO PULL THROUGH THE GROUND THAN THEN #9 SHANK. THEREFORE WILL RESULT IN HIGHER PULLING FORCE REQUIRED AND/OR THE SHANK ASSEMBLY WILL BREAK OUT AT SHALLOWER WORKING DEPTHS. IF THE INVERSION SHANK IS RECOILED, IT WILL NOT PERFORM CORRECTLY AND CONTINUED USE MAY RESULT IN INCREASED WEAR OR DAMAGE TO THE ASSEMBLY.

AGROWFLOW COPYRIGHT RESERVED <small>THIS DRAWING IS THE PROPERTY AGROWFLOW PTY LTD, AND IS SUBJECT TO RETURN UPON DEMAND. IT IS SUBMITTED FOR USE ONLY IN CONNECTION WITH PROPOSALS OR CONTRACTS OF THIS ORGANISATION UPON THE EXPRESS CONDITION THAT IT IS NOT TO BE USED DIRECTLY OR INDIRECTLY IN ANY WAY DETRIMENTAL TO THE INTERESTES OF AGROWFLOW PTY LTD.</small>	TITLE: #9 INVERSION SHANK ASSEMBLY 600 RIGID	PART NUMBER 024-1002
17-Feb-17		SHEET: SHEET 1 OF 2

1 2 3 4 5 6

A
B
C
D

A
B
C
D

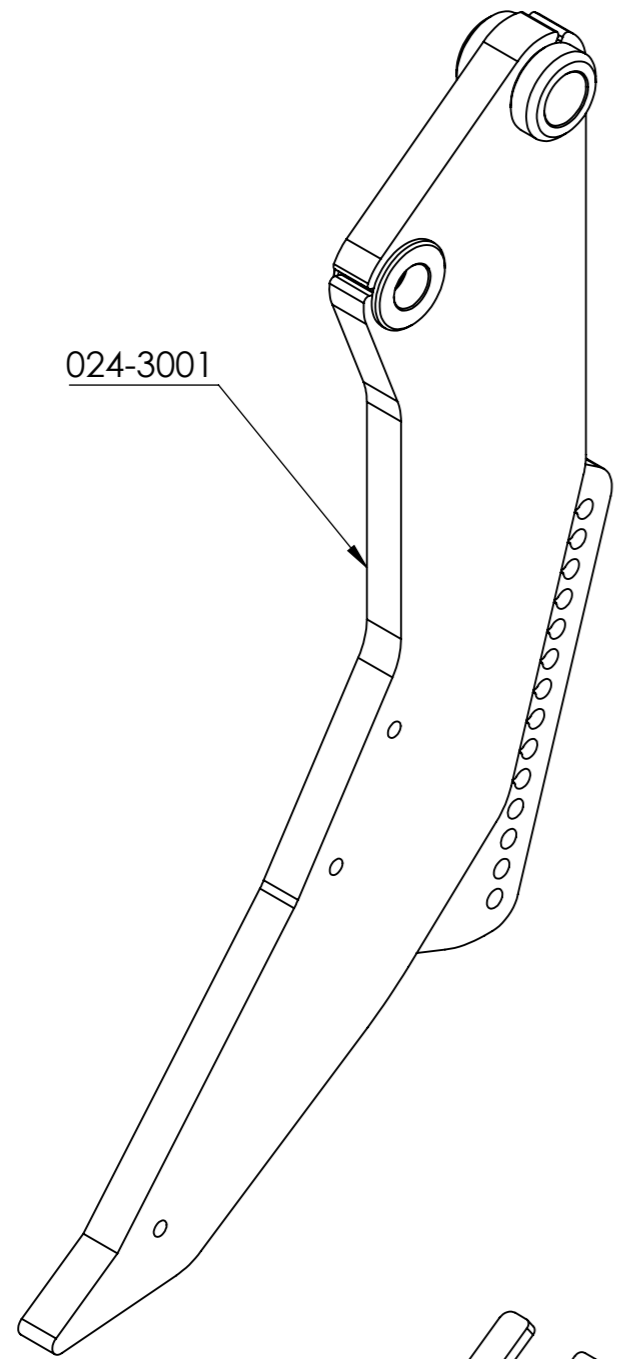

024-3001

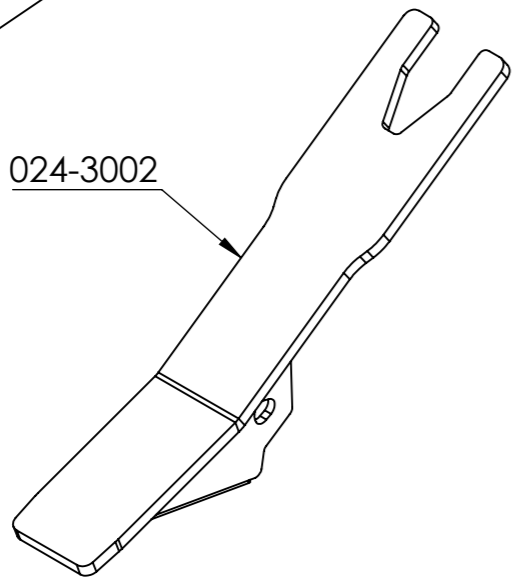

024-3002

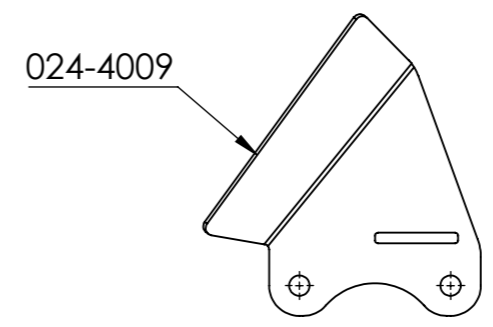

024-4009

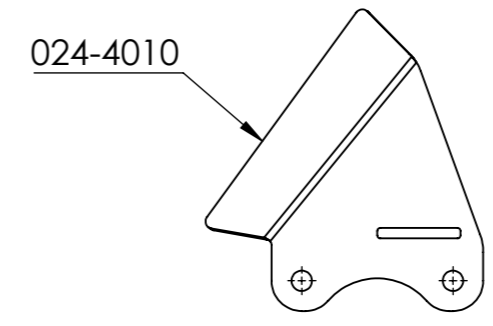
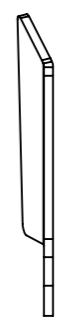

024-4010

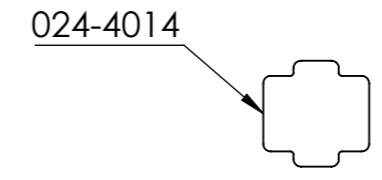

024-4014



AGROWFLOW	TITLE: #9 INVERSION SHANK ASSEMBLY 600 RIGID	PART NUMBER 024-1002
<small>COPYRIGHT RESERVED THIS DRAWING IS THE PROPERTY AGROWFLOW PTY LTD, AND IS SUBJECT TO RETURN UPON DEMAND. IT IS SUBMITTED FOR USE ONLY IN CONNECTION WITH PROPOSALS OR CONTRACTS OF THIS ORGANISATION UPON THE EXPRESS CONDITION THAT IT IS NOT TO BE USED DIRECTLY OR INDIRECTLY IN ANY WAY DETRIMENTAL TO THE INTERESTES OF AGROWFLOW PTY LTD.</small>		

1 2 3 4 5 6