

#1 HYDRAULIC RECOIL SHANK ASSEMBLY

THE MOST ADVANCED SHANK JUMP ACTION MADE

Recoil mechanism allows both jump and twist action to overcome stubborn obstructions.

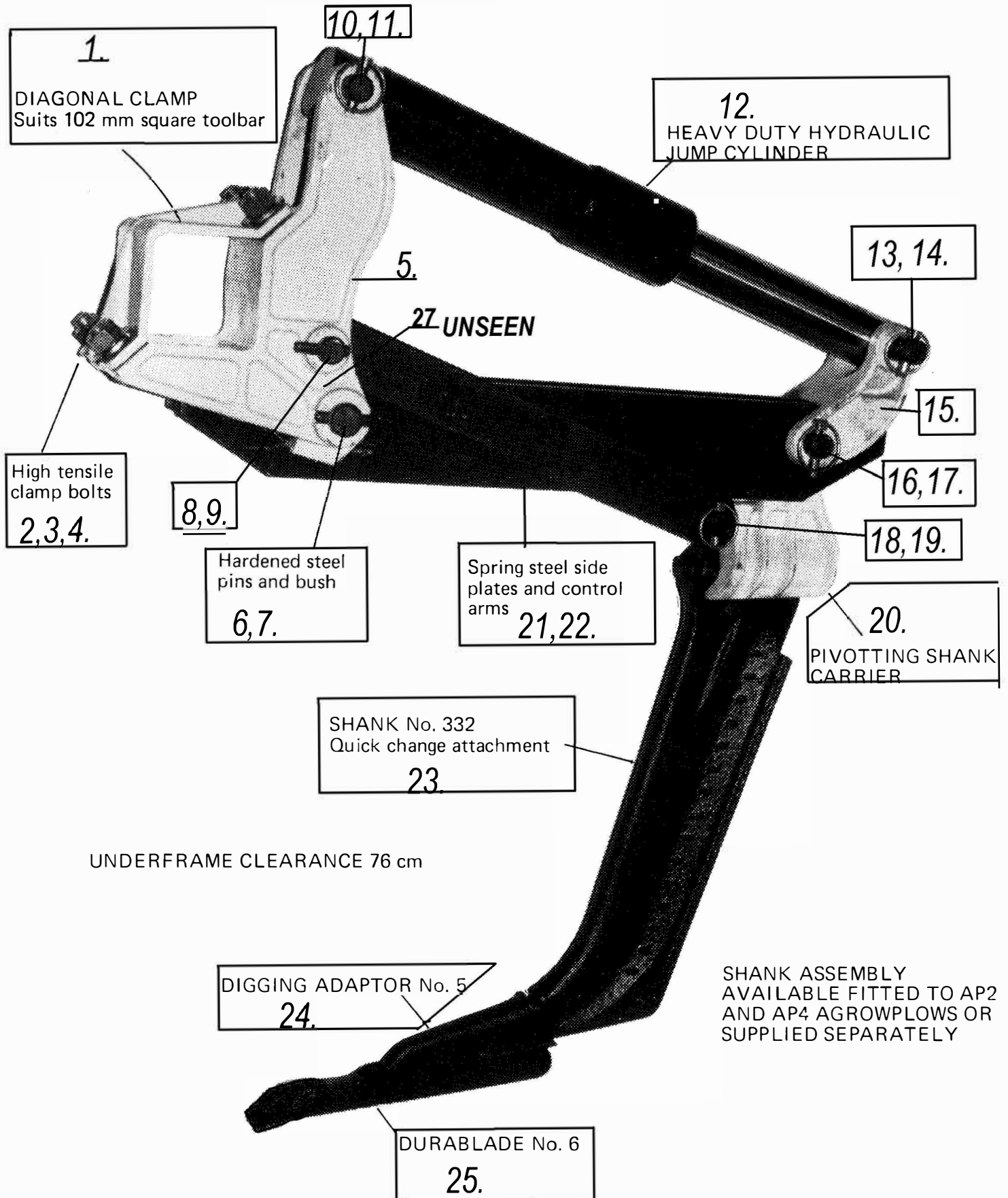

LOWER H.P. REQUIREMENTS – NON INVERSION AND MINIMUM SOIL DISTURBANCE.

