



3-Way/Multi-Switch Installation Guide

4-Wire Switches & Dimmers

 WARNING: RISK OF ELECTRIC SHOCK

This product installation requires handling 120 volt wiring.

Follow each step carefully.

If any concerns handling wiring, hire a qualified electrician.

Ensure all work meets applicable local and national codes.

Simple DIY Setup



Install
your Smart
Switch



Download
the C by GE app



Add
your Smart Switch to
the C by GE app



GET IT ON
Google Play



Download on the
App Store

Compatibility Requirements

Rating 120V AC 60Hz

Neutral wire is required
(Wire is usually white
or grey)

Ground wire is required
(Wire is usually green,
green with a yellow stripe,
or copper) 

Wi-Fi 802.11 b/g/n @ 2.4 GHZ
is required

Works with halogen,
incandescent and LED bulbs,
including C by GE Smart
Bulbs.

LED up to 1.25 amps

Incandescent/halogen
up to 5 amps

Motor up to 1/4HP

! IMPORTANT NOTE ON 3-WAY WIRING:

Some lights have one wall switch, while others are controlled by two or more wall switches (such as stair lights, which have a switch at both the top and bottom of the stairs). If your lights have more than one switch (called a 3-way), we've created instructions for how to install and enable the capability.

Visit cbyge.com/switch-support
for 3-way installation instructions and how-to-videos.

Let's Do It

INCLUDED



Switch



Wall Plate



4 Wire Nuts



4 Phillips
Mounting Screws

Line

Load

Ground



Neutral



Wire Labels

YOU'LL NEED



Phillips Screwdriver



Needle Nose Pliers
(recommended)



Voltage Tester
(recommended)



Approximately
30 minutes of your day
to install and setup
the switch

You Got This!

And we're here to help.
For in-depth instructional videos
and a guided tour through the installation,
go to cbyge.com/switch-support.

BEFORE YOU DO ANYTHING: Step 1

Turn Off The Power!

1. Turn off the power for the switch location at the circuit breaker box.
2. Remove wall plates and mounting screws for both switches you are replacing.
3. Gently pull switches out from their boxes so wiring can be viewed.
4. Test the wires with a voltage tester to ensure power is off. If multiple switches are in the same box, test them as well. Additional breakers may need to be turned off.

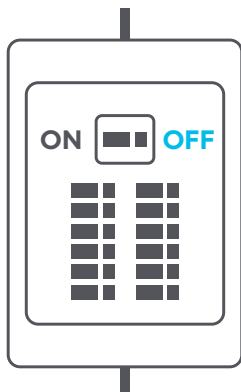

STEP 2

Check For Compatible Wiring

1. Do not disconnect any wires at this stage. We recommend taking a picture of your wiring before proceeding for future reference.
2. Wiring colors may vary. In this diagram, neutral is white, and ground is bare copper. The red and black wires connected to brass terminals are traveler wires. The wires connected to the black (common) terminals are the line and load (we'll identify which one is which in STEP 4).
3. Both the neutral and ground wires are required for the C by GE Smart Switch.
4. If neutral wires are only in one switch location, the traveler wire will be used to carry the neutral to the other switch (this will be explained on STEP 7.B).
5. If all necessary wiring is present, you can proceed with installation.

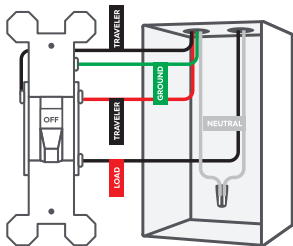
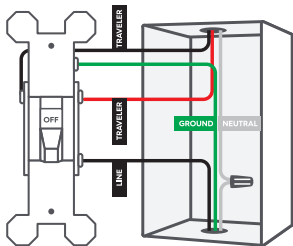

STEP 2

Check For Compatible Wiring

6. If installing a 4-way, check for compatible wiring on the 4-way switch.

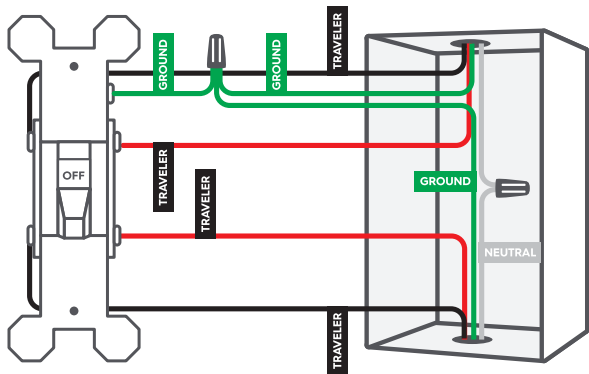

STEP 3

Restore Power

1. Restore power to the switches at the circuit breaker box.

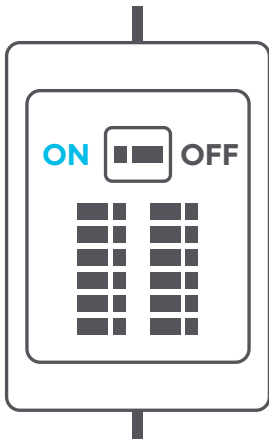

STEP 4

Identify The LINE And LOAD

1. Make sure that the light is off. Then, check the black common terminals on both switches using a voltage tester. One of them should test positive for voltage, and the other one should not.

Wire that has voltage = LINE

Wire that doesn't have voltage = LOAD

2. The wire box that houses your line wire will be your line side box/switch while the box that houses your load wire will be your load side box/switch.
3. If you are installing a 4-way/multi-way setup, the 4-way switch will have 2 black screws and 2 copper colored screws.

BEFORE YOU DO ANYTHING: Step 5

Turn Off The Power!

1. Turn off the power for the switch location at the circuit breaker box.

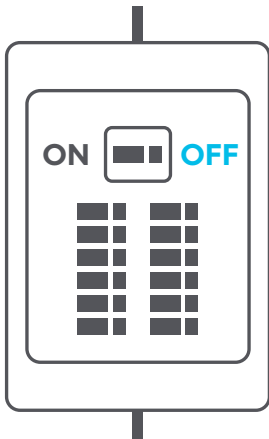

STEP 6.A

Identify And Label Wires

1. Before disconnecting the wires from the switch, label each wire with the provided labels.

Line:

Based on STEP 4, label the LINE wire that did test positive for voltage.

Load:

Based on STEP 4, label the LOAD wire that did not test positive for voltage.

Neutral:

Standard switches do not require them, but the neutral wires will be present in the box. Look for two or more wires (usually white) not connected to the switch and grouped together with a wire nut. In the event that only one switch box has a neutral, use STEP 7.B for additional wiring instructions.

Ground:

These are usually a group of bare copper or green wires that are sometimes connected to the green ground terminal of the original switch. If not connected to the original switch, they should be in the back of the box.

Travelers:

The traveler wires are connected to the brass screws on the original switches. These wires are in the same sheathed cable and should be different colors that can vary between black, white, or red. One of these wires will be used to provide power to the C by GE Smart Switch on the load side of the circuit. If only one box has a neutral wire, the second traveler will be used as well. Follow instructions shown on STEP 7.B for this situation.

NOTE: If you're installing a 4-way switch, the travelers will be connected to the copper colored and black screws.

STEP 6.B

Identify And Label Wires

3-Way Install

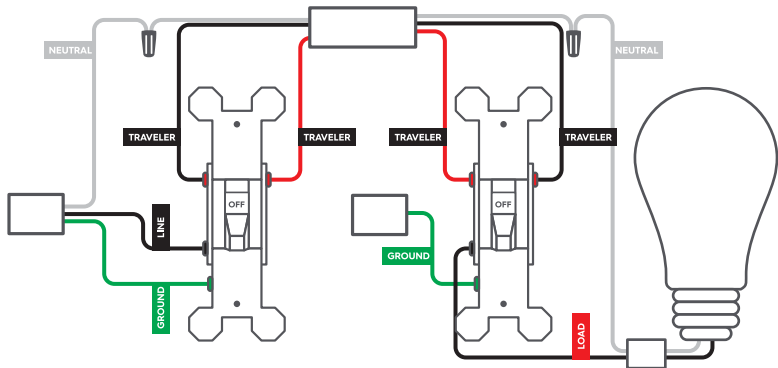

STEP 6.C

Identify And Label Wires

4-Way/Multi-Way Install

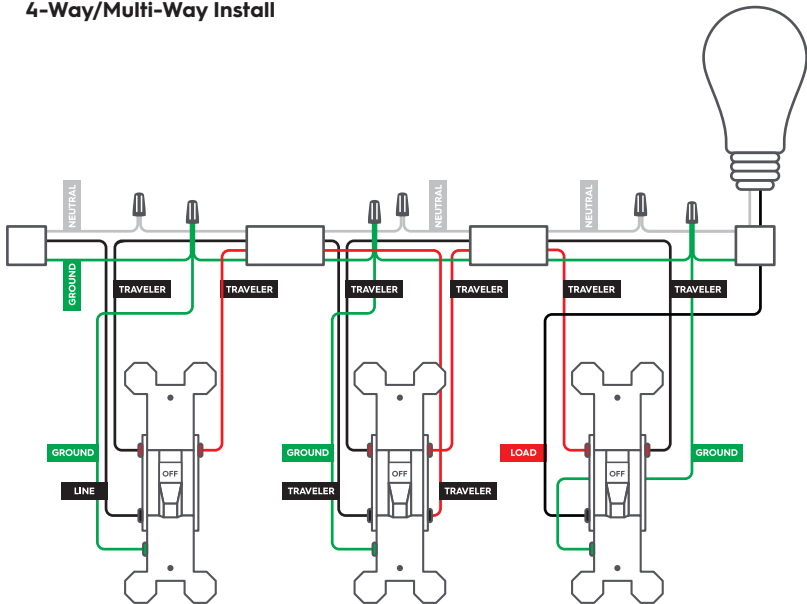

STEP 7.A

Install The Switches

1. Now that you have successfully identified and labeled each wire, you can disconnect the wires and remove the original switches.

Installing Switches Where Neutral Wires Exist in Both Boxes

Line Side

1. Connect the LINE wire and one of the TRAVELER wires from the wall to the black LINE wire on the C by GE Smart Switch.
2. Connect all NEUTRAL wires from the wall to the white NEUTRAL wire on the C by GE Smart Switch.
3. Cap the red LOAD wire on the C by GE Smart Switch.
4. Connect the GROUND wire from the wall to the green GROUND wire on the C by GE Smart Switch.
5. Cap the second TRAVELER wire from the wall. This wire is not needed.

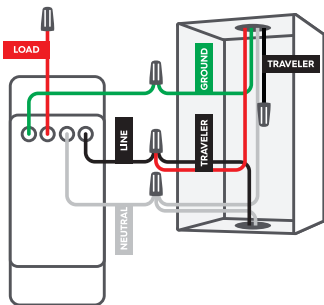

STEP 7.A

Install The Switches

Load Side

1. Connect the TRAVELER connected to the black LINE wire in the first box to the black LINE wire on the C by GE Smart Switch.
2. Connect all NEUTRAL wires from the wall to the white NEUTRAL wire on the C by GE Smart Switch.
3. Connect the LOAD wire from the wall to the red LOAD wire on the C by GE Smart Switch.
4. Connect the GROUND wire from the wall to the green GROUND wire on the C by GE Smart Switch.
5. Cap the second TRAVELER wire from the wall. This wire is not needed.

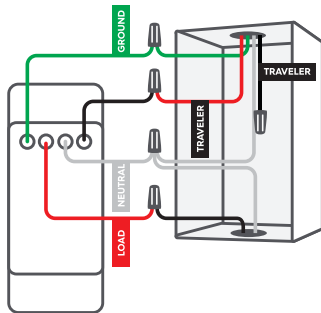

STEP 7.A

Install The Switches

If installing a 4-way/Multi-Way setup: 4-Way Switch

1. Connect the GROUND wire from the wall to the green GROUND wire on the C by GE Smart Switch.
2. Cap the red LOAD wire on the C by GE Smart Switch.
3. Connect the NEUTRAL wires that are associated with that circuit/switch group from the wall to the white NEUTRAL wire on the C by GE Smart Switch. **IMPORTANT:** If unsure which NEUTRAL wire is in which circuit/switch group, contact C by GE customer support or a certified electrician.
4. Connect the two red TRAVELER wires to the black LINE wire on the C by GE Smart Switch.
5. Cap the two black TRAVELER wires from the wall. These wires are not needed.

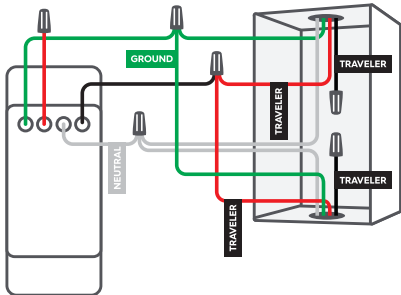

STEP 7.B

Install The Switches

Connect Additional Traveler Wire (Neutral Wires Exist in Only One Box)

Line Side

1. The NEUTRAL wires should be in this location. Add the second TRAVELER wire from the wall to all NEUTRAL wires.

Load Side

1. Connect the second TRAVELER wire to the white NEUTRAL wire on the C by GE Smart Switch.

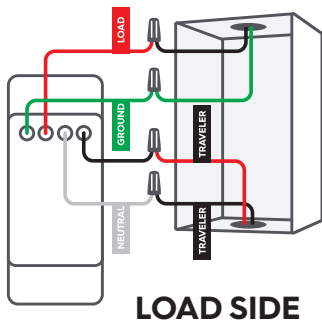
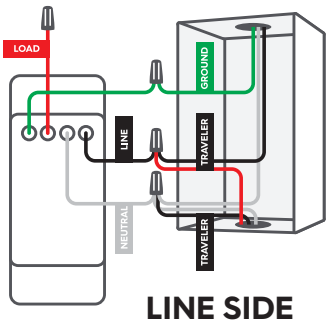

STEP 7.B

Install The Switches

If installing a 4-way/Multi-Way setup: 4-Way Switch

1. Connect the GROUND wire from the wall to the green GROUND wire on the C by GE Smart Switch.
2. Cap the red LOAD wire on the C by GE Smart Switch.
3. Connect the two black TRAVELER wires to the white NEUTRAL wire on the C by GE Smart Switch.
4. Connect the two red TRAVELER wires in the wall to the black LINE wire on the C by GE Smart Switch.

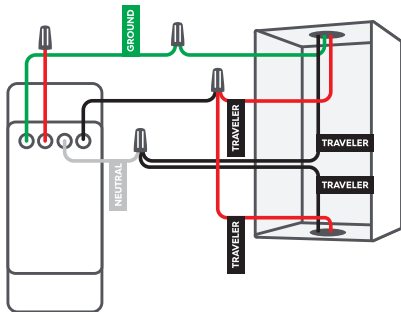

STEP 8

Check For Functionality

IMPORTANT: Only the load switch will turn the light on/off until the two smart switches are linked in the C by GE app. The dimmer buttons will not work on either switch until the two smart switches are linked in the C by GE app. We will handle the app setup in STEP 12.

1. Restore power to the switches at the circuit breaker box.
2. The light ring on both switches will flash blue indicating the switches are wired correctly. If you see this, proceed to STEP 9.
3. Light ring may not illuminate if wired incorrectly.
4. The light ring will flash red if the circuit is overloaded. Max load rating is 150W for LED and 450W for incandescent/halogen.
5. If lights don't turn on:
 - Check that the air gap on the bottom of switch is fully inserted (dimmer/motion switches only).
 - Check that power to the switch is back on at the breaker.
 - Turn power off at the breaker, return to the switch to confirm the wires are securely and properly wired according to the installation guide.

BEFORE YOU DO ANYTHING: Step 9

Turn Off The Power!

1. Turn off the power for the switch location at the circuit breaker box.

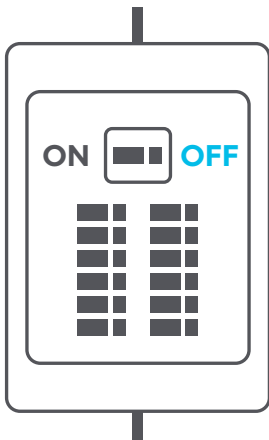

STEP 10

Secure The Switch

1. Neatly push the wires back into the boxes.
2. Using the screws provided, secure the switch to the wall until level and flush.
3. Using the screws provided, secure the face plate bracket.
4. Snap the face plate cover onto the bracket.

STEP 11

Restore Power

1. Restore power to the switches at the circuit breaker box.

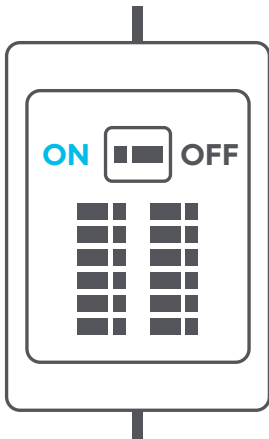

STEP 12

Enable 3-Way/Multi-Way Control in The C by GE App

NOTE: Only the Load switch will turn the light on/off until the smart switches are linked in the C by GE app. Dimmer mode can be enabled during the setup.

1. Download the C by GE app.
2. Add switches to the same location in the C by GE app.
3. The light ring for each switch should change from flashing blue to solid white.
4. Create a ROOM in the C by GE app.
5. Add switches to that ROOM.
6. Test that your 3-Way/Multi-Way switches operate correctly.