



# 7/8" CORRUGATED

Installation, Flashings & Shop Drawing Detail Guide



Western States Metal Roofing  
901 W. Watkins Street  
Phoenix, AZ 85007

Phone:  
(877) 787-5467  
(855) 426-7836

Email:  
sales@cortenroofing.com  
sales@metalforroofing.com

For More Information:  
[www.cortenroofing.com](http://www.cortenroofing.com)  
[www.metalforroofing.com](http://www.metalforroofing.com)

# Western States 7/8" Corrugated

Installation, Flashings & Shop Drawing Detail Guide

# Table of Contents

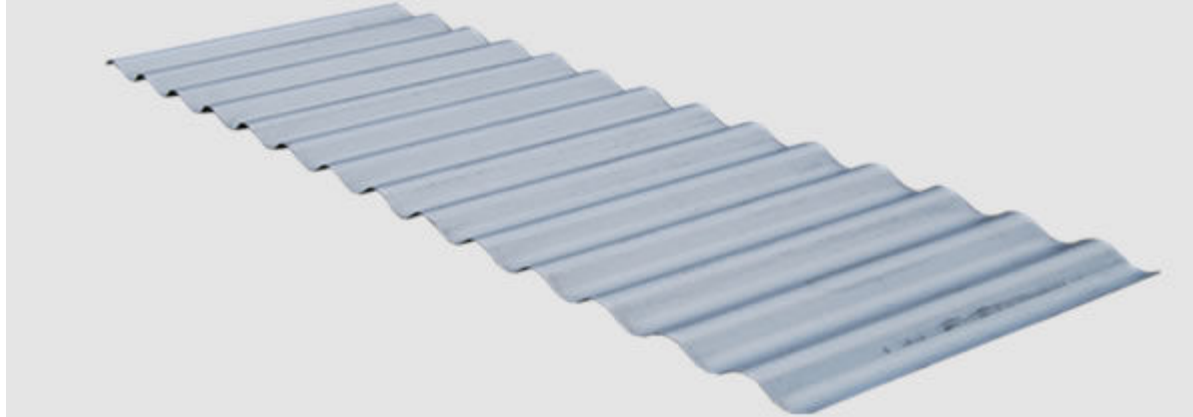

<b>Section</b>	<b>Page</b>	<b>Section</b>	<b>Page</b>
Notes to Designer / Installers.....	1	Valley .....	21
Fastener Placement and Selection.....	2-3	Pitch Break High to Low .....	22
Key Roof Plan .....	4	Pitch Break Low to High .....	23
Key Flashing / Trims.....	5-6-7-8	Chimney .....	24-25
Eave Detail .....	9	Pipe Flashing .....	26
Mini Eave Detail .....	10	Wall Detail .....	27
Eave Pre Hung Gutter .....	11	Wall Detail Isometric.....	28
Eave Post Hung Gutter .....	12	Wall Base trim .....	29
Gutter Splice .....	13	Outside Corner .....	30
Gable Flashing .....	14	Inside Corner .....	31
Mini Gable Flashing .....	15	Notes.....	32
Peak/ High Eave .....	16	Custom Trim Form .....	33
Sidewall .....	17	Special Design Considerations.....	34
Endwall .....	18		
Formed Ridge .....	19		
Hip and Ridge .....	20		

## **Western States 7/8" Corrugated Panel**

Installation, Flashings & Shop Drawing Detail Guide

### **Notes to Designer and Installers**

The details contained in this guide are proven industry details and are intended to be used as a design aid and installation guide. It does not depict all situations that may be encountered on all projects. Modifications are the responsibility of the designer/ owner/ installer. Consideration should be given for Fit for Purpose, Building use, Climate conditions such as temperature, snow, wind, and moisture, Governing Building Codes, and Maintenance. It is highly recommended that all trims and flashings be of the same material as the panels (metal, gauge, finish) to ensure long term performance and durability. Where possible, flashing edges should be hemmed to strengthen the edge and protect the cut edge from exposure.

### **Framing and Substrates**

7/8" Corrugated panels are used over all type of substrates like Steel Decking, open purlins, spaced sheathing, and wood decking such as plywood. Most details in this guide are shown with panels attached to solid wood substrates.

### **Note on underlayment**

Not all conditions require an underlayment, However metal roofing is susceptible to Condensation and it is recommended that an appropriate Roofing underlayment be use on all wood substrates to protect the structure during installation. For added protection from rain and snow, it is recommended to use rubberized Ice and water shield on eaves, valleys, and areas of roof penetrations.

### **Slope Requirements**

It is recommended that 7/8" Corrugated panels have a minimum slope requirement of 3:12 on all structures.

### **Valley and Snow Design**

Valley design and dimension must be the proper width to accommodate high snow, rain, ice, and slope conditions. If possible, splices, penetrations, valleys, roof elevation changes, should be minimized in areas of high snow and ice accumulations.

### **Oil Canning**

Oil canning is a condition common with flat metal surfaces. This waviness is caused by steel mill tolerances, forming, variations in the structures surfaces, and hardness of the steel. Measures are taken at the roll forming process, like profile design, steel gauge, corrective leveling, to minimize the effects of oil canning. Oil Canning is a Characteristic of steel and can not be eliminated totally and therefore is not reason for rejection of the panels.

### **Job Site Storage**

While waiting to be installed on the job site, Storage of panels, trim crates, and flat sheet should be sloped in order to allow for proper moisture run off. One end should be elevated so as not to allow ponding of water on the metal surface. When using tarps for protection, proper ventilation should be provided to prevent condensation. Moisture or condensation that is trapped inside a bundle can lead to white rust on sheeting.

### **References**

For other installation techniques and details, The Sheet Metal and Air Conditioning Contractors National Association Inc. (SMACNA) and NRCA manuals are great resources for working with sheet metal.

### **Technical Assistance**

Contact your WSDI sales or technical representative for any additional information or assistance.

## Western States 7/8" Corrugated Panel

Installation, Flashings & Shop Drawing Detail Guide

### Fastener Placement and Selection

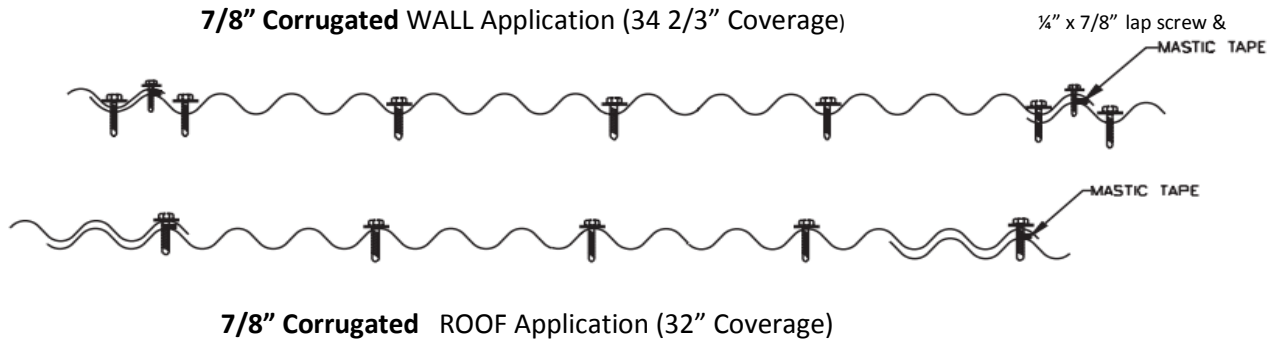

#### Notes to Installers:

- Fastener Selection will vary depending on type and thickness of substrate.
- Space panel lap screws 12" minimum -18" O.C. maximum. Consult with design engineer.
- Spacing of fastener rows to be engineered by others.
- Lap panels away from prevailing winds whenever possible.
- The use of Butyl tape mastic is always recommended on the panel lap when used for roof panels.
- Panels and flashings should never be installed in contact with dissimilar metals.
- Use only those flashings and accessories designed for use with this panel.
- Panel attachment screws must be long enough to fully penetrate through roof deck substrate or penetrate solid lumber at least one inch.
- Exposed Fasteners should have sealing washers and be coated to provide protection against corrosion.
- Screws must be properly driven to ensure holding strength and proper seal. (see diagram)
- Recommended drill speed is 2000rpm. Improper setting of drill speed can lead to snapping of screw heads.
- Pre drilling of screw holes may be necessary with heavy gauge metals.

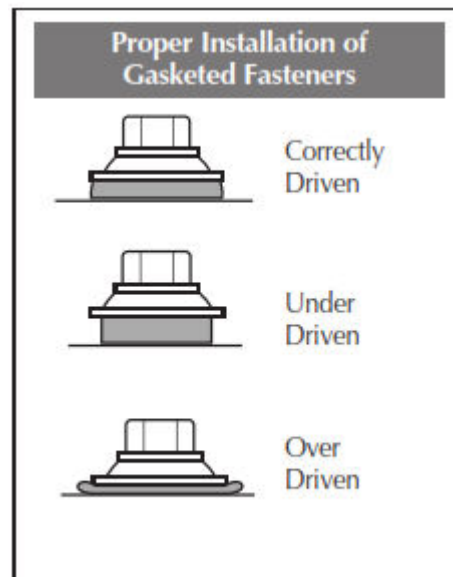

**Western States 7/8" Corrugated Panel**  
 Installation, Flashings & Shop Drawing Detail Guide

**Fastener Selection**

Description

Application

#9 x1" Wood Drillers  
 #9 x 1.5" Wood Drillers  
 #9 x2" Wood Drillers

Used to attach panels to dimensional Lumber and plywood

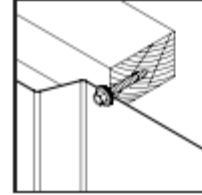

#12-14 x 1" SD  
 #12- 14 x1.5" SD  
 #12- 14 x 2" SD  
 #12-24 x1.25"sd

Used to attach panels to Purlins and other metal substrates

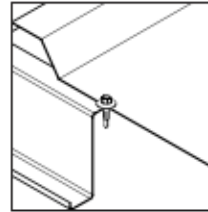

#14 x 7/8" Lap Self tap  
 #14 x7/8 Lap Stainless

Used to attach Trims and panel side laps. Stainless to be used with A606-4 Steel

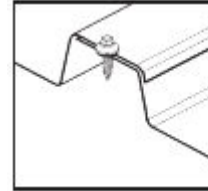

#10-12 x1" Pancake Wood  
 #10-12 x 1" SD Self Driller

Used to secure trims to substrates. Also available in Stainless Steel.



1/8" Stainless Rivets

Used for Trim to Trim attachment or trim to wall panels.



Stainless Screws  
 #10 x1 Wood Driller  
 #10 x 1.5 Wood Driller  
 #10 x 2" Wood Driller

Used for panel attachment for panels made with A606-4 Steel



- The table above shows the panel Fasteners provided by WSD. Special order screws are available.



FLASHING TYPE

DETAIL NO.

STANDARD TRIM	WSD-ST5
STANDARD TRIM	WSD-ST6
STANDARD TRIM	WSD-ST7
STANDARD TRIM	WSD-ST8
EAVE	WSD-E1
MINI EAVE	WSD-ME2
EAVE PRE-HUNG GUTTER	WSD-EG1
EAVE POST-HUNG GUTTER	WSD-EG2
PRE-HUNG GUTTER SPLICE	WSD-EG3
GABLE FLASHING	WSD-GF1
MINI-GABLE FLASHING	WSD-MGF2
PEAK-HIGH EAVE FLASHING	WSD-PK3
SIDEWALL FLASHING	WSD-SW4
ENDWALL FLASHING	WSD-EW5
FORMED RIDGE	WSD-FR6
RIDGE-HIP	WSD-RH6
VALLEY FLASHING	WSD-V7
PITCH BREAK HIGH TO LOW	WSD-PB8
PITCH BREAK LOW TO HIGH	WSD-PB9
CHIMNEY FLASHING	WSD-CF10
CHIMNEY FLASHING	WSD-CF11
PIPE FLASHING	WSD-PF12
WALL DETAILS	WSD-W13
ISOMETRIC WALL DETAIL	WSD-W14
WALL DETAIL	WSD-W15
WALL DETAIL	WSD-W16
WALL DETAIL	WSD-W17
NOTES	WSD-N18
CUSTOM TRIM SHEET	WSD-CT19

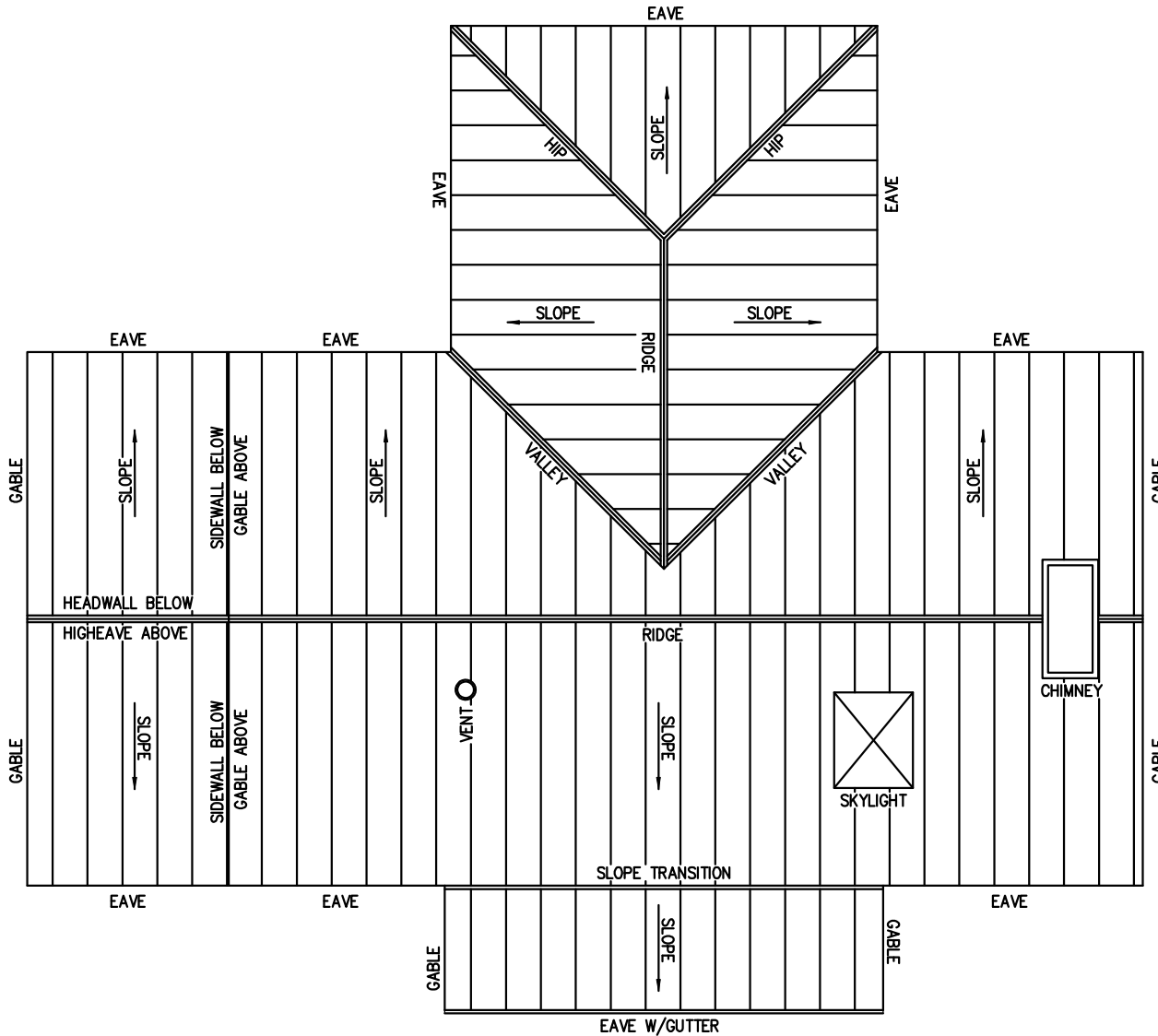

# Western States Metal Roofing

901 W. Watkins St.  
 Phoenix, AZ 85007  
[www.MetalForRoofing.com](http://www.MetalForRoofing.com)  
[www.RustedRoofing.com](http://www.RustedRoofing.com)  
[www.MetalDeck.com](http://www.MetalDeck.com)

Phone: (602) 495-0048  
 Fax: (602) 261-7726  
 877-PURLINS (787-5467)



DETAIL:

## KEY ROOF PLAN

PANEL TYPE:

**7/8" Corrugated**

B	01-14-13
A	06-01-12
REV:	DATE:
DETAIL #:	

<p><b>EAVE FLASHING WS-4</b></p>	<p><b>MINI EAVE FLASHING WS-40</b></p>	<p><b>PITCH BREAK HIGH TO LOW WS-36</b></p>	<p><b>PITCH BREAK LOW TO HIGH WS-37</b></p>
<p><b>CUSTOM TRIM REGLET FLASHING WS-29</b></p>	<p><b>GABLE FLASHING WS-16-UGF</b></p>	<p><b>MINI GABLE FLASHING WS-41</b></p>	<p><b>PEAK/HIGH EAVE FLASHING WS-19</b></p>
<p><b>ENDWALL FLASHING WS-28</b></p>	<p><b>OVERSIZED VALLEY WS-23</b></p>	<p><b>STANDARD VALLEY WS-24</b></p>	<p><b>EXTENDED VALLEY WS-25</b></p>

## Western States Metal Roofing

901 W. Watkins St.  
 Phoenix, AZ 85007  
[www.MetalForRoofing.com](http://www.MetalForRoofing.com)  
[www.RustedRoofing.com](http://www.RustedRoofing.com)  
[www.MetalDeck.com](http://www.MetalDeck.com)

Phone: (602) 495-0048  
 Fax: (602) 261-7726  
 877-PURLINS (787-5467)

### STANDARD TRIM

PANEL TYPE:

7/8" Corrugated

B 01-14-13

A 06-01-12

REV: DATE:

DETAIL #:  
**WSD-ST5**



<p><b>SIDEWALL FLASHING WS-7-78U</b></p>	<p><b>JAMB TRIM WS-3-78U</b></p>	<p><b>HEAD TRIM WS-8-78U</b></p>	<p><b>BASE TRIM WS-6-78U</b></p>
<p><b>OUTSIDE CORNER WS-47-UOC</b></p>	<p><b>OUTSIDE CORNER WS-55-UOC</b></p>	<p><b>INSIDE CORNER WS-46-UIC</b></p>	<p><b>INSIDE CORNER WS-56-UIC</b></p>
<p><b>INSIDE CORNER WS-77-UIC</b></p>	<p><b>RIDGE/HIP CAP WS-5</b></p> <p>* DENOTES ANGLE</p>	<p><b>RIDGE/HIP CAP WS-5H</b></p> <p>* DENOTES ANGLE</p>	<p><b>RIDGE/HIP CAP WS-20</b></p> <p>* DENOTES ANGLE</p>

# Western States Metal Roofing

901 W. Watkins St.  
 Phoenix, AZ 85007  
[www.MetalForRoofing.com](http://www.MetalForRoofing.com)  
[www.RustedRoofing.com](http://www.RustedRoofing.com)  
[www.MetalDeck.com](http://www.MetalDeck.com)

Phone: (602) 495-0048  
 Fax: (602) 261-7726  
 877-PURLINS (787-5467)

## STANDARD TRIM

PANEL TYPE:

**7/8" Corrugated**

B 01-14-13

A 06-01-12

REV: DATE:

DETAIL #:  
**WSD-ST6**

<p><b>RIDGE/HIP CAP WS-20H</b></p>	<p><b>DIE FORMED RIDGE CAP WS-21</b></p> <p>* 6:12 PITCH MAX.</p> <p>* AVAILABLE IN 24GA ONLY</p>	<p><b>GUTTER STRAP WS-12</b></p>	<p><b>BOX GUTTER END CAP WS-14</b></p>
<p><b>SCULPTURE PRE-HUNG GUTTER WS-1</b></p>	<p><b>BOX GUTTER PRE-HUNG WS-10</b></p>	<p><b>BOX GUTTER POST-HUNG WS-15</b></p>	<p><b>SCULPTURE POST-HUNG GUTTER WS-17</b></p>
<p><b>SPLICE WS-13 FOR BOX GUTTER</b></p> <p>* 12" LONG</p>	<p><b>SPLICE WS-60 FOR SCULPTURE GUTTER</b></p> <p>* 12" LONG</p>	<p><b>DOWNSPOUT STRAIGHT WS-26</b></p>	<p><b>DOWNSPOUT WITH KICKOUT WS-27</b></p>

## Western States Metal Roofing

901 W. Watkins St.  
 Phoenix, AZ 85007  
[www.MetalForRoofing.com](http://www.MetalForRoofing.com)  
[www.RustedRoofing.com](http://www.RustedRoofing.com)  
[www.MetalDeck.com](http://www.MetalDeck.com)

Phone: (602) 495-0048  
 Fax: (602) 261-7726  
 877-PURLINS (787-5467)

### STANDARD TRIM

PANEL TYPE:

7/8" Corrugated

B 01-14-13

A 06-01-12

REV: DATE:

DETAIL #:  
**WSD-ST7**

DOWNSPOUT ELBOW WS-43	DOWNSPOUT OUTLET WS-75	DOWNSPOUT STRAP WS-42	SCULPTURE GUTTER END CAP WS-49

# Western States Metal Roofing

901 W. Watkins St.  
 Phoenix, AZ 85007  
[www.MetalForRoofing.com](http://www.MetalForRoofing.com)  
[www.RustedRoofing.com](http://www.RustedRoofing.com)  
[www.MetalDeck.com](http://www.MetalDeck.com)

Phone: (602) 495-0048  
 Fax: (602) 261-7726  
 877-PURLINS (787-5467)

**STANDARD TRIM**

PANEL TYPE:

**7/8" Corrugated**

B	01-14-13
---	----------

A	06-01-12
---	----------

REV:	DATE:
------	-------

DETAIL #:	<b>WSD-ST8</b>
-----------	----------------

NOTE:  
FOR HIGH SNOW AREA THE OVERHANG  
SHOULD BE 1" MAX.

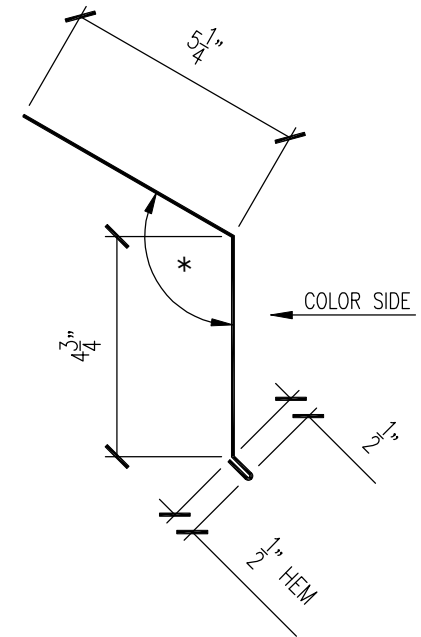
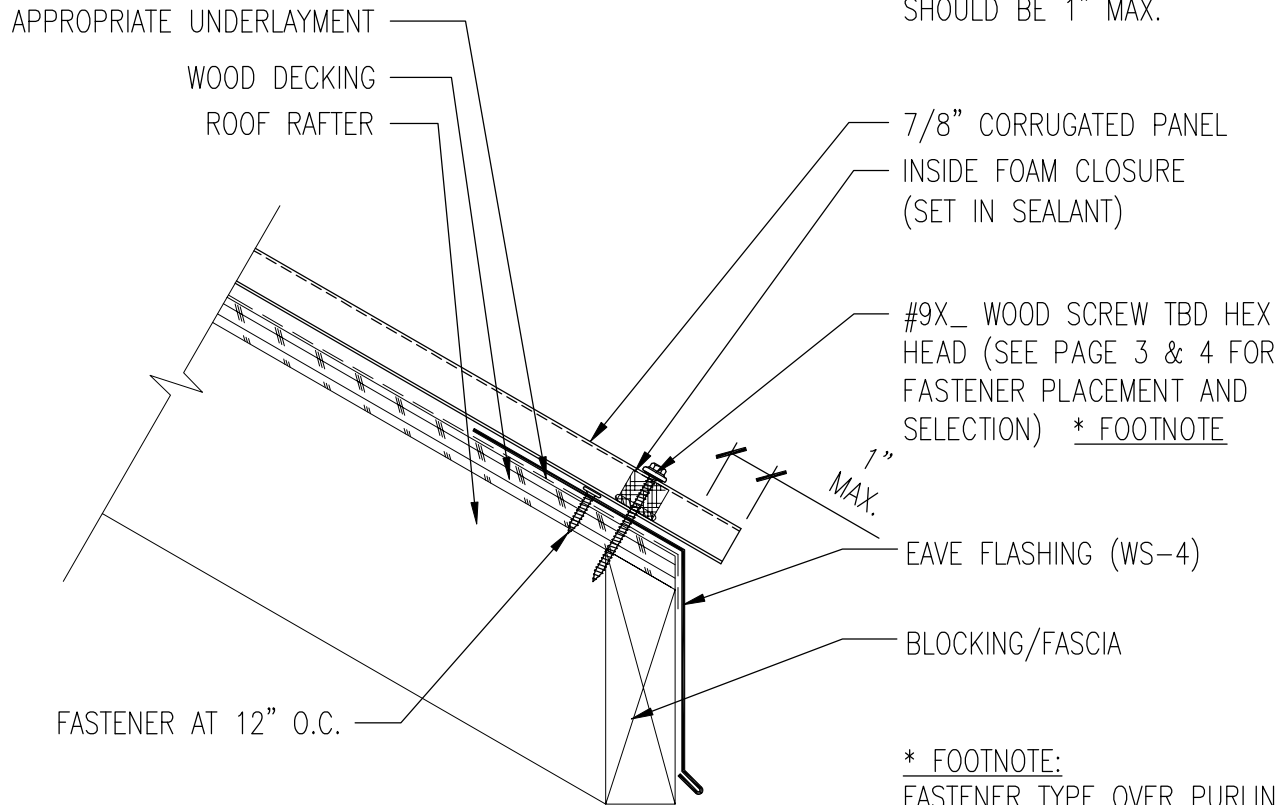

\* FOOTNOTE:  
FASTENER TYPE OVER PURLINS  
TO BE #12X SELF DRILLER  
FASTENER

EAVE FLASHING (WS-4)  
\* DENOTES ANGLE

GAUGE: _____	COLOR: _____
BREAKS: _____	FINISH: _____
LENGTH: _____	STRETCH OUT: _____
MATERIAL: _____	

## Western States Metal Roofing

901 W. Watkins St.  
Phoenix, AZ 85007  
www.MetalForRoofing.com  
www.RustedRoofing.com  
www.MetalDeck.com

Phone: (602) 495-0048  
Fax: (602) 261-7726  
877-PURLINS (787-5467)

EAVE DETAIL	B	01-14-13
	A	06-01-12
PANEL TYPE: 7/8" Corrugated	REV:	DATE:
	DETAIL #:	WSD-E1

NOTE:  
FOR HIGH SNOW AREA THE OVERHANG  
SHOULD BE 1" MAX.

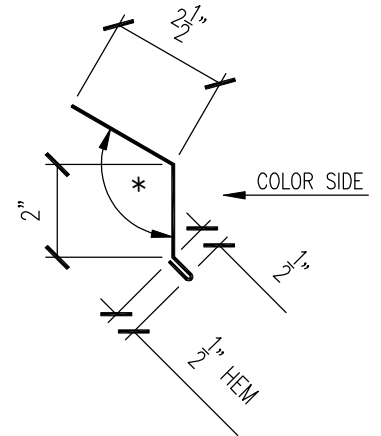
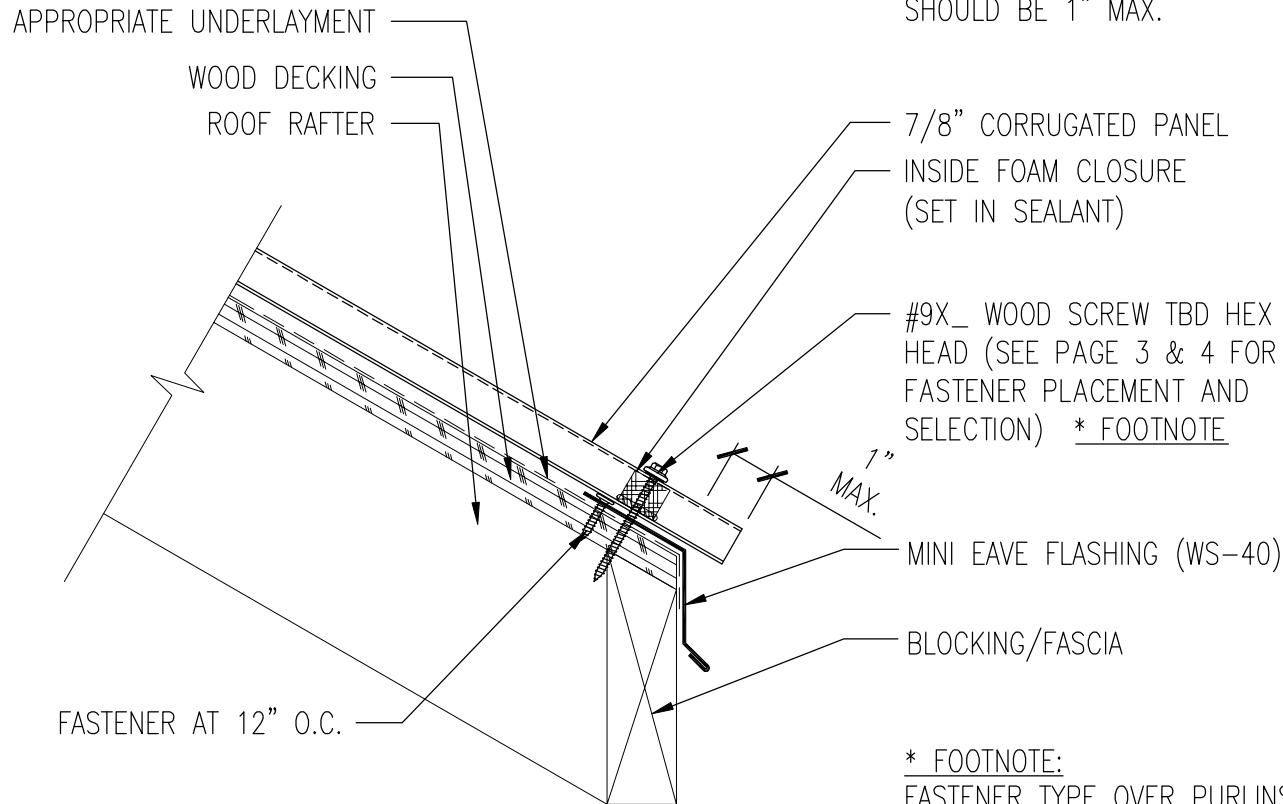

MINI EAVE FLASHING  
(WS-40)

\* DENOTES ANGLE

\* FOOTNOTE:  
FASTENER TYPE OVER PURLINS  
TO BE #12X SELF DRILLER  
FASTENER

GAUGE: _____	COLOR: _____
BREAKS: _____	FINISH: _____
LENGTH: _____	STRETCH OUT: _____
MATERIAL: _____	

## Western States Metal Roofing

901 W. Watkins St.  
Phoenix, AZ 85007  
www.MetalForRoofing.com  
www.RustedRoofing.com  
www.MetalDeck.com

Phone: (602) 495-0048  
Fax: (602) 261-7726  
877-PURLINS (787-5467)

MINI EAVE DETAIL	B	01-14-13
	A	06-01-12
PANEL TYPE: <b>7/8" Corrugated</b>	REV:	DATE:
	DETAIL #:	<b>WSD-ME2</b>

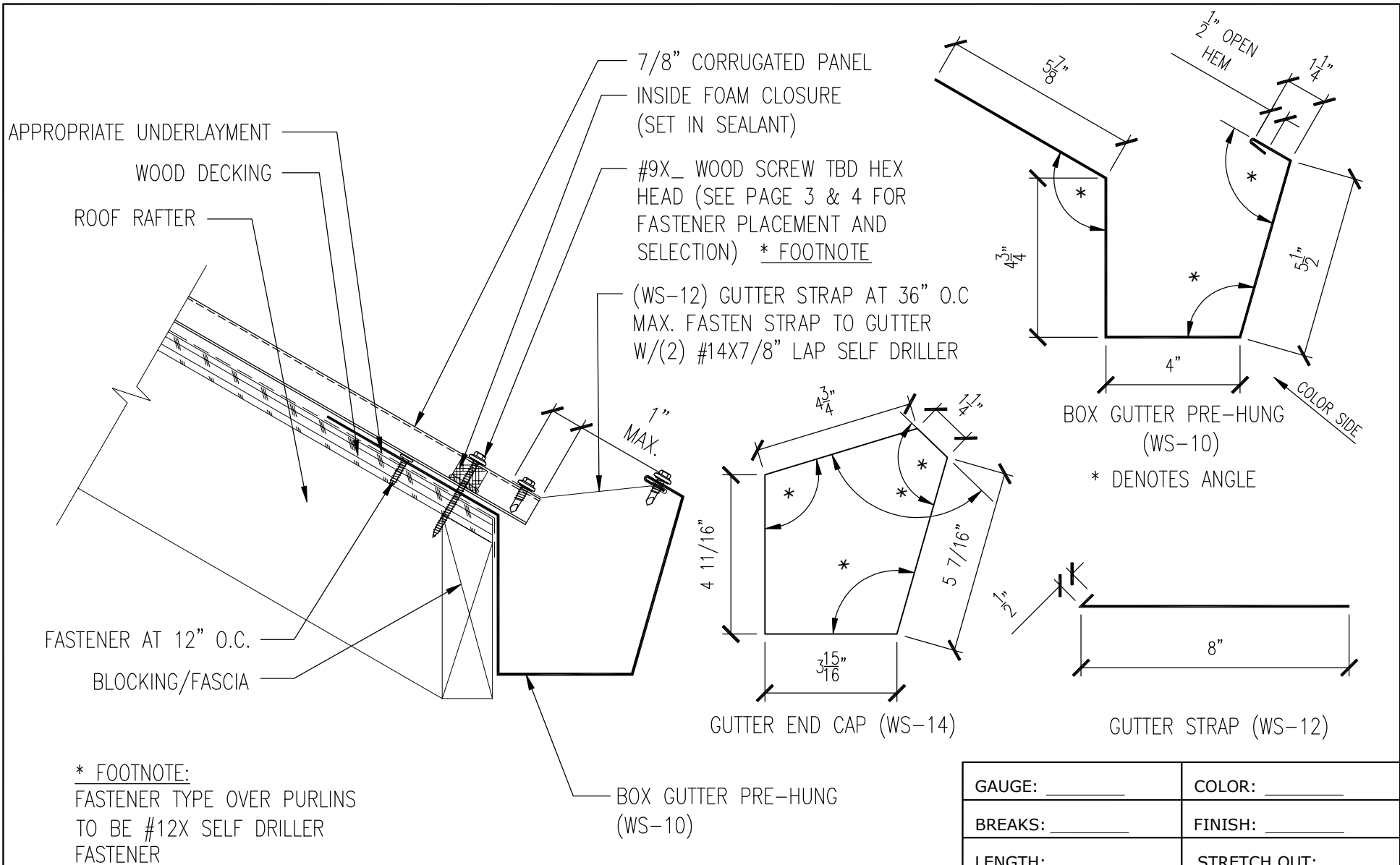

GAUGE: _____	COLOR: _____
BREAKS: _____	FINISH: _____
LENGTH: _____	STRETCH OUT: _____
MATERIAL: _____	

# Western States Metal Roofing

901 W. Watkins St.  
Phoenix, AZ 85007  
www.MetalForRoofing.com  
www.RustedRoofing.com  
www.MetalDeck.com

Phone: (602) 495-0048  
Fax: (602) 261-7726  
877-PURLINS (787-5467)

EAVE DETAIL PRE-HUNG GUTTER DETAIL	B	01-14-13
	A	06-01-12
PANEL TYPE: 7/8" Corrugated	REV:	DATE:
	DETAIL #:	WSD-EG1

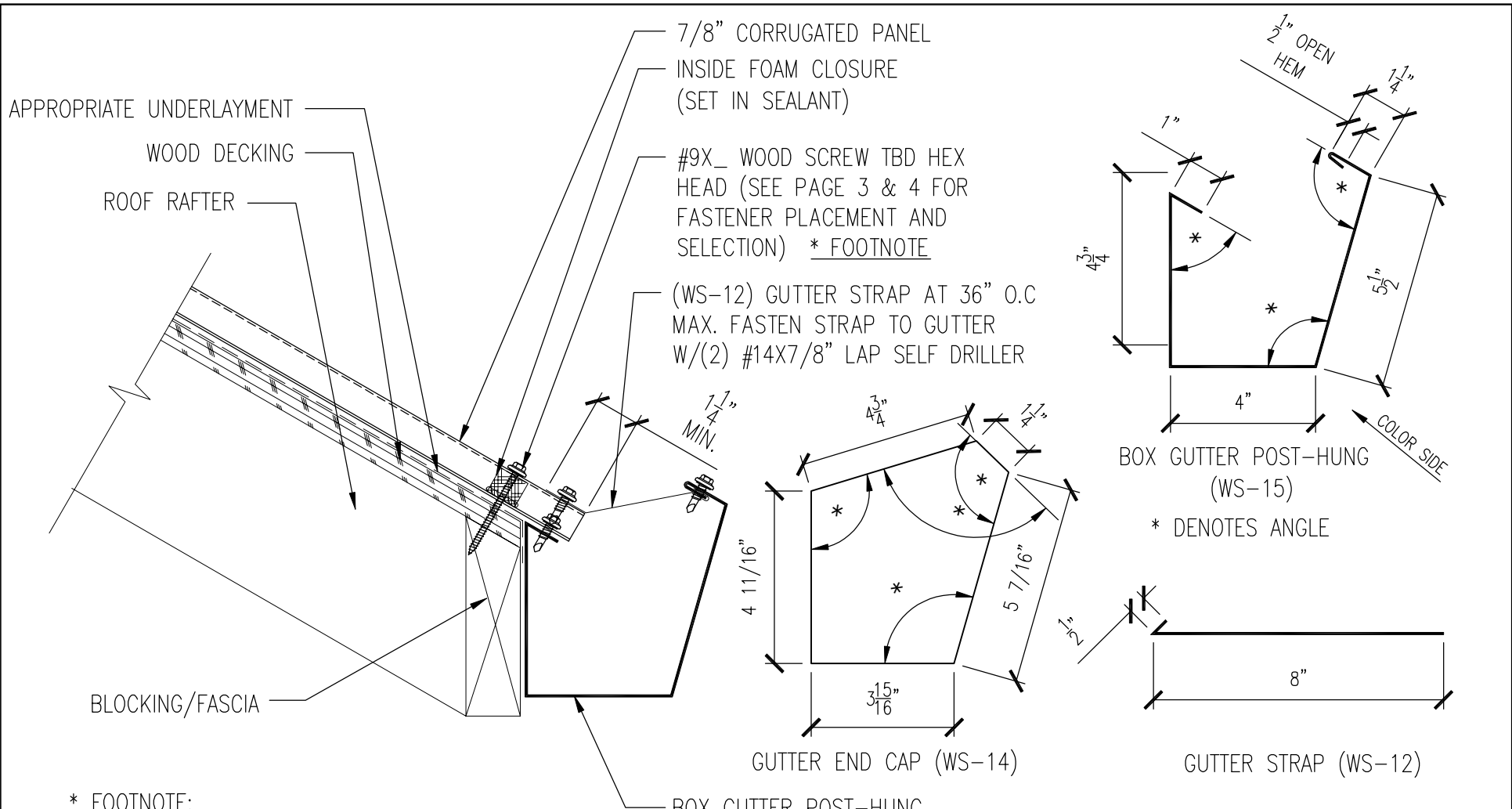

\* FOOTNOTE:  
 FASTENER TYPE OVER PURLINS  
 TO BE #12X SELF DRILLER  
 FASTENER

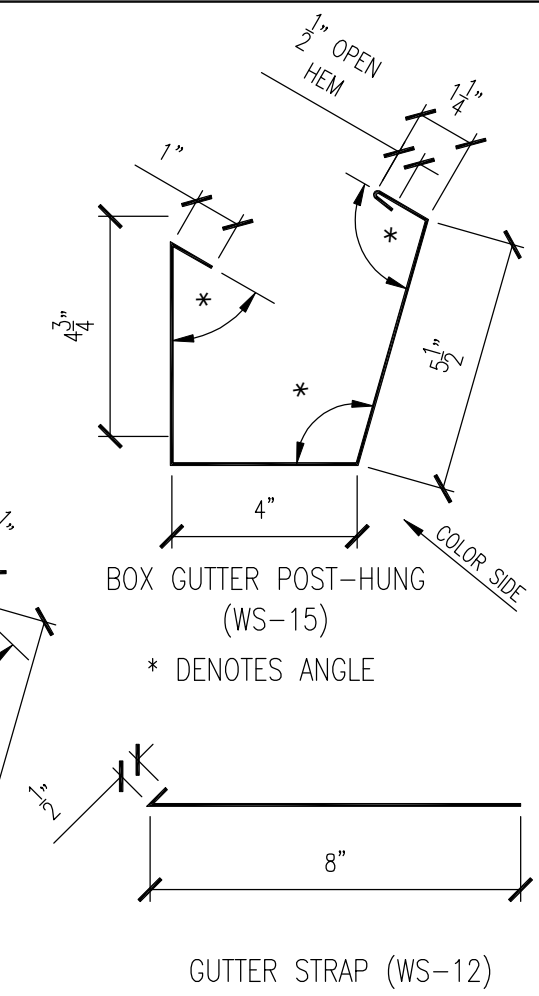

**Western States Metal Roofing**  
 901 W. Watkins St. Phone: (602) 495-0048  
 Phoenix, AZ 85007 Fax: (602) 261-7726  
 www.MetalForRoofing.com 877-PURLINS (787-5467)  
 www.RustedRoofing.com  
 www.MetalDeck.com

GAUGE: _____	COLOR: _____	
BREAKS: _____	FINISH: _____	
LENGTH: _____	STRETCH OUT: _____	
MATERIAL: _____		
EAVE DETAIL POST HUNG GUTTER DETAIL	B	01-14-13
	A	06-01-12
PANEL TYPE: 7/8" Corrugated	REV:	DATE:
	DETAIL #: WSD-EG2	

"FOR POST/PRE-HUNG GUTTER"

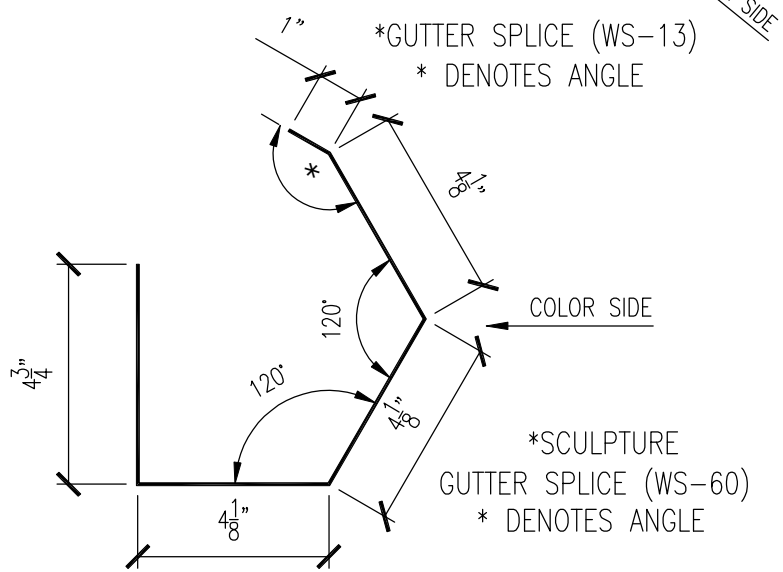
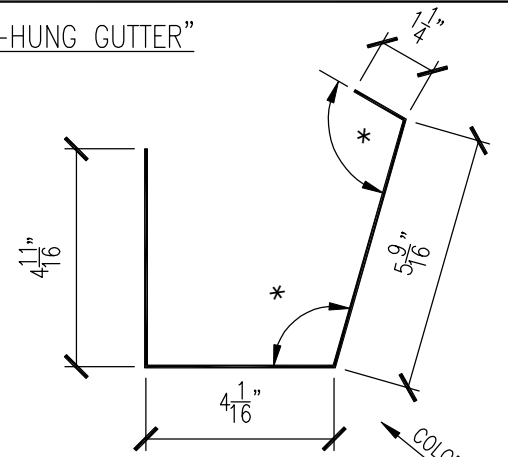
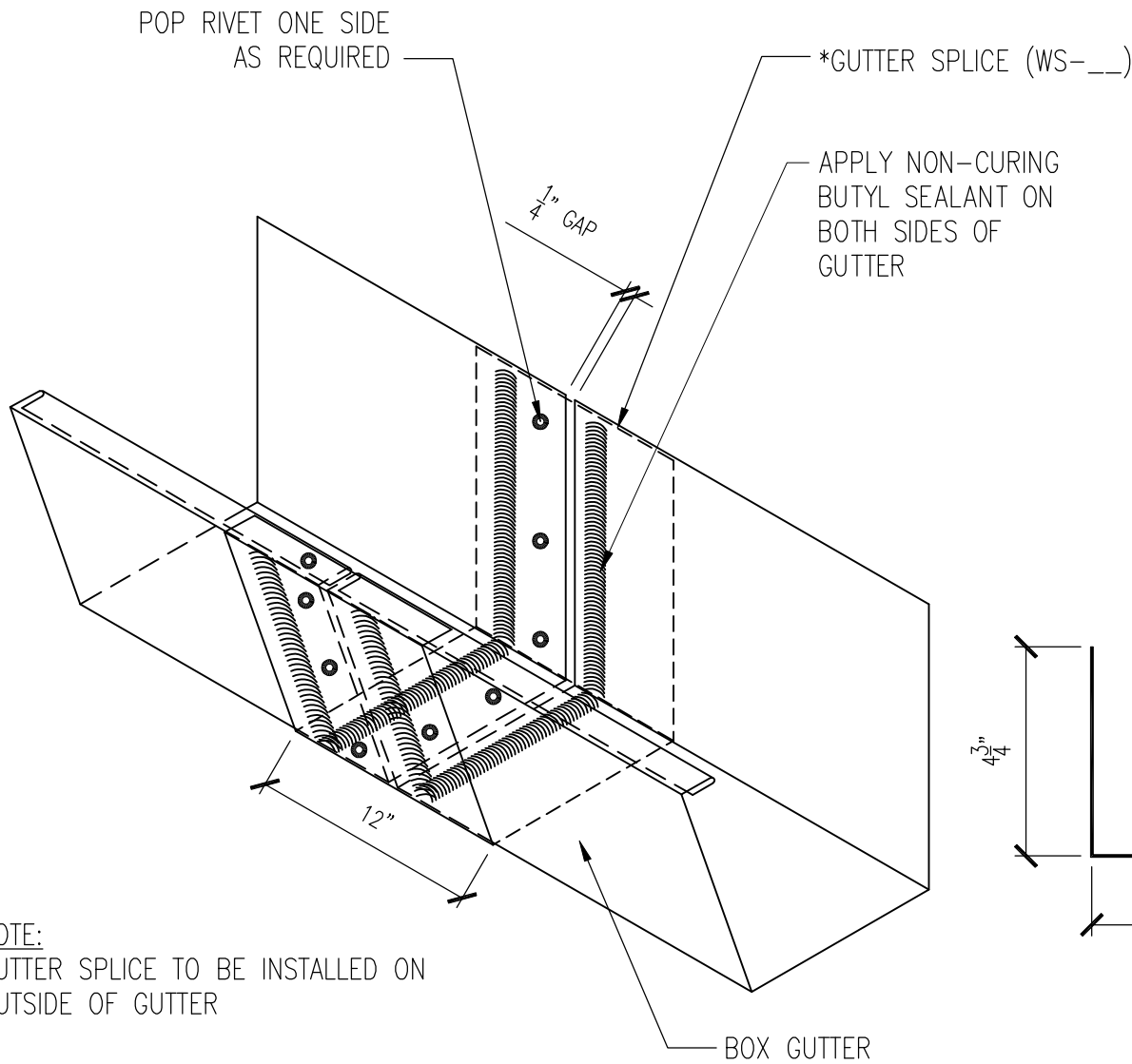

NOTE:  
GUTTER SPLICE TO BE INSTALLED ON  
OUTSIDE OF GUTTER

GAUGE: _____	COLOR: _____
BREAKS: _____	FINISH: _____
LENGTH: _____	STRETCH OUT: _____
MATERIAL: _____	

## Western States Metal Roofing

901 W. Watkins St.  
Phoenix, AZ 85007  
www.MetalForRoofing.com  
www.RustedRoofing.com  
www.MetalDeck.com

Phone: (602) 495-0048  
Fax: (602) 261-7726  
877-PURLINS (787-5467)

PRE-HUNG GUTTER SPLICE DETAIL	B	01-14-13
	A	06-01-12
PANEL TYPE: 7/8" Corrugated	REV:	DATE:
		DETAIL #: WSD-EG3



#14X7/8" LAP SELF DRILLER  
@ 12" O.C. MAX.

BUTYL TAPE SEAL

GABLE FLASHING  
(WS-16-UGF)

#9X\_ WOOD SCREW TBD HEX  
HEAD

BLOCKING/FASCIA

#9X\_ WOOD SCREW TBD HEX  
HEAD (SEE PAGE 3 & 4 FOR  
FASTENER PLACEMENT AND  
SELECTION) \* FOOTNOTE

7/8" CORRUGATED PANEL

COLOR SIDE

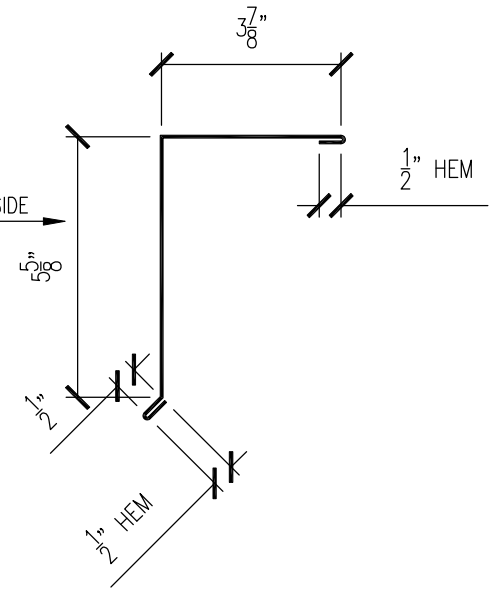

GABLE FLASHING  
(WS-16-UGF)

APPROPRIATE UNDERLAYMENT

WOOD DECKING

ROOF RAFTER

\* FOOTNOTE:  
FASTENER TYPE OVER PURLINS  
TO BE #12X SELF DRILLER  
FASTENER

GAUGE: _____	COLOR: _____
BREAKS: _____	FINISH: _____
LENGTH: _____	STRETCH OUT: _____
MATERIAL: _____	

## Western States Metal Roofing

901 W. Watkins St.  
Phoenix, AZ 85007  
www.MetalForRoofing.com  
www.RustedRoofing.com  
www.MetalDeck.com

Phone: (602) 495-0048  
Fax: (602) 261-7726  
877-PURLINS (787-5467)

GABLE FLASHING DETAIL	B	01-14-13
	A	06-01-12
PANEL TYPE: 7/8" Corrugated	REV:	DATE:
	DETAIL #: WSD-GF1	

#14X7/8" LAP SELF DRILLER  
@ 12" O.C. MAX.

BUTYL TAPE SEAL

MINI GABLE FLASHING  
(WS-41)

#9X\_ WOOD SCREW TBD HEX  
HEAD

BLOCKING/FASCIA

#9X\_ WOOD SCREW TBD HEX  
HEAD (SEE PAGE 3 & 4 FOR  
FASTENER PLACEMENT AND  
SELECTION) \* FOOTNOTE

7/8" CORRUGATED PANEL

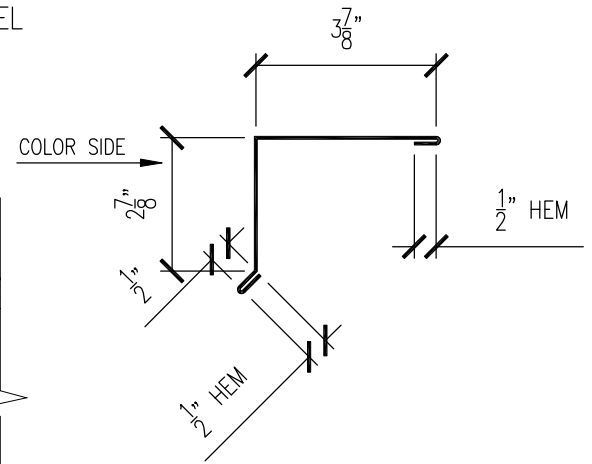

MINI GABLE FLASHING  
(WS-41)

APPROPRIATE UNDERLAYMENT

WOOD DECKING

ROOF RAFTER

\* FOOTNOTE:  
FASTENER TYPE OVER PURLINS  
TO BE #12X SELF DRILLER  
FASTENER

GAUGE: _____	COLOR: _____
BREAKS: _____	FINISH: _____
LENGTH: _____	STRETCH OUT: _____
MATERIAL: _____	

## Western States Metal Roofing

901 W. Watkins St.  
Phoenix, AZ 85007  
www.MetalForRoofing.com  
www.RustedRoofing.com  
www.MetalDeck.com

Phone: (602) 495-0048  
Fax: (602) 261-7726  
877-PURLINS (787-5467)

MINI GABLE FLASHING DETAIL	B	01-14-13
	A	06-01-12
PANEL TYPE: 7/8" Corrugated	REV:	DATE:
	DETAIL #:	WSD-MGF2

#14X7/8" LAP SELF DRILLER  
@ 12" O.C. MAX.

BUTYL TAPE SEAL

PEAK FLASHING  
(WS-19)

BUTYL TAPE SEAL

#9X\_ WOOD SCREW TBD HEX  
HEAD

BLOCKING/FASCIA

APPROPRIATE UNDERLAYMENT

WOOD DECKING

ROOF RAFTER

OUTSIDE FOAM CLOSURE  
(SET IN SEALANT)

7/8" CORRUGATED PANEL

#9X\_ WOOD SCREW TBD HEX  
HEAD (SEE PAGE 3 & 4 FOR  
FASTENER PLACEMENT AND  
SELECTION) \* FOOTNOTE

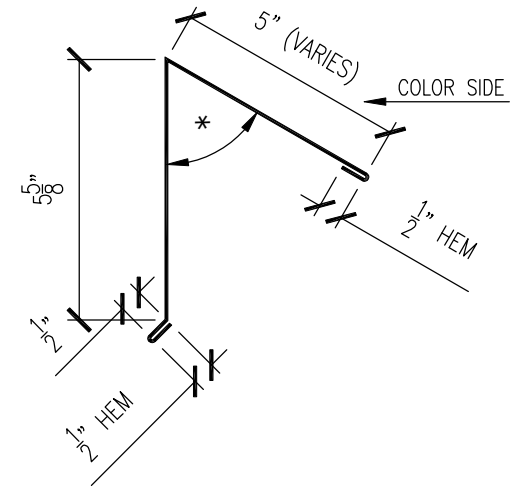

PEAK FLASHING/HIGH EAVE FLASHING  
(WS-19)

\* DENOTES ANGLE

\* FOOTNOTE:  
FASTENER TYPE OVER PURLINS  
TO BE #12X SELF DRILLER  
FASTENER

GAUGE: _____	COLOR: _____
BREAKS: _____	FINISH: _____
LENGTH: _____	STRETCH OUT: _____
MATERIAL: _____	

## Western States Metal Roofing

901 W. Watkins St.  
Phoenix, AZ 85007  
www.MetalForRoofing.com  
www.RustedRoofing.com  
www.MetalDeck.com

Phone: (602) 495-0048  
Fax: (602) 261-7726  
877-PURLINS (787-5467)

PEAK FLASHING/ HIGH EAVE DETAIL	B	01-14-13
	A	06-01-12
PANEL TYPE: 7/8" Corrugated	REV:	DATE:
	DETAIL #: WSD-PK3	

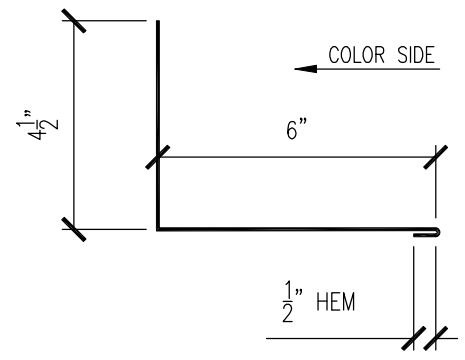
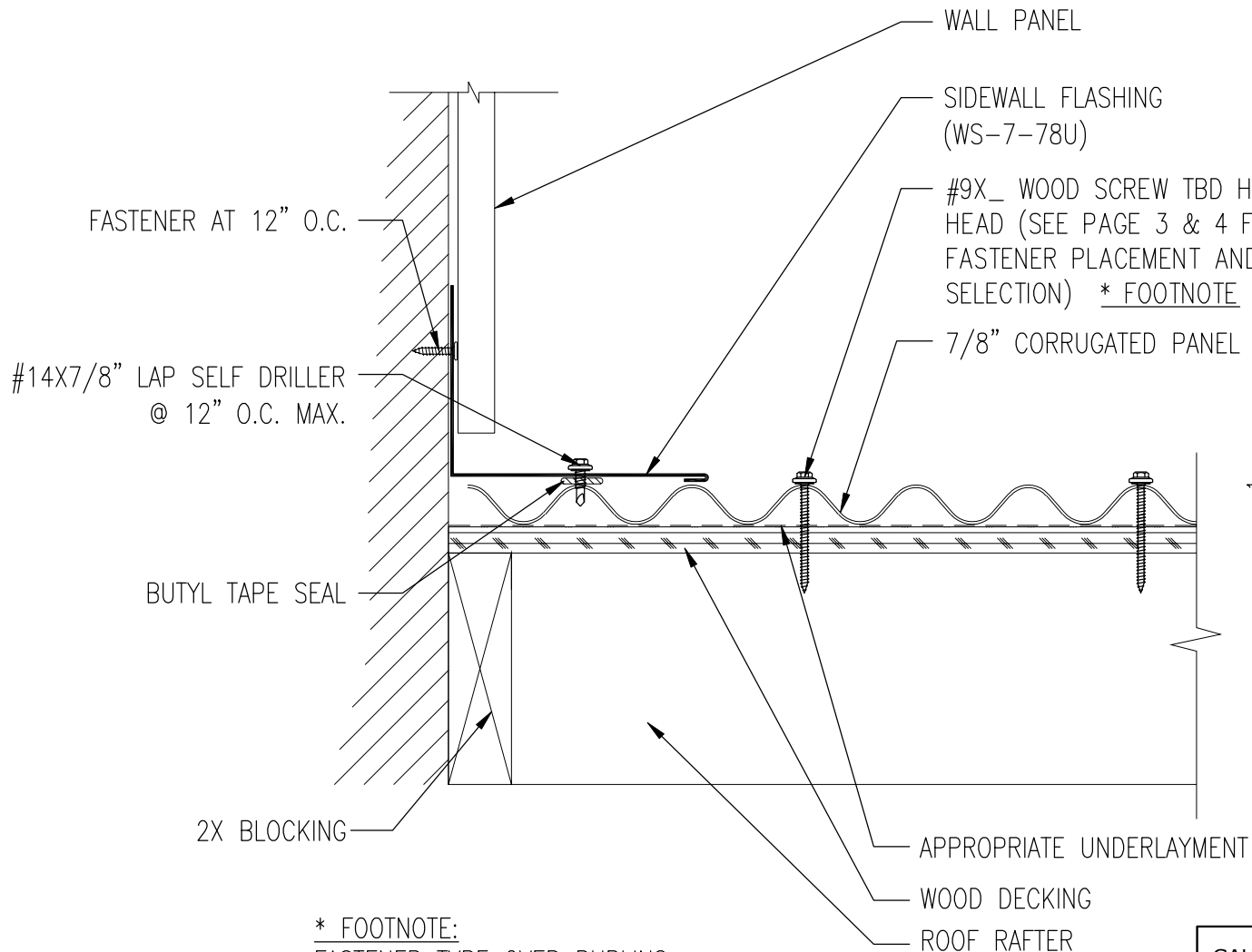

SIDEWALL FLASHING  
(WS-7-78U)

\* FOOTNOTE:  
FASTENER TYPE OVER PURLINS  
TO BE #12X SELF DRILLER  
FASTENER

GAUGE: _____	COLOR: _____
BREAKS: _____	FINISH: _____
LENGTH: _____	STRETCH OUT: _____
MATERIAL: _____	

## Western States Metal Roofing

901 W. Watkins St.  
Phoenix, AZ 85007  
www.MetalForRoofing.com  
www.RustedRoofing.com  
www.MetalDeck.com

Phone: (602) 495-0048  
Fax: (602) 261-7726  
877-PURLINS (787-5467)

SIDEWALL FLASHING DETAIL	B	01-14-13
	A	06-01-12
PANEL TYPE: <b>7/8" Corrugated</b>	REV:	DATE:
	DETAIL #:	<b>WSD-SW4</b>

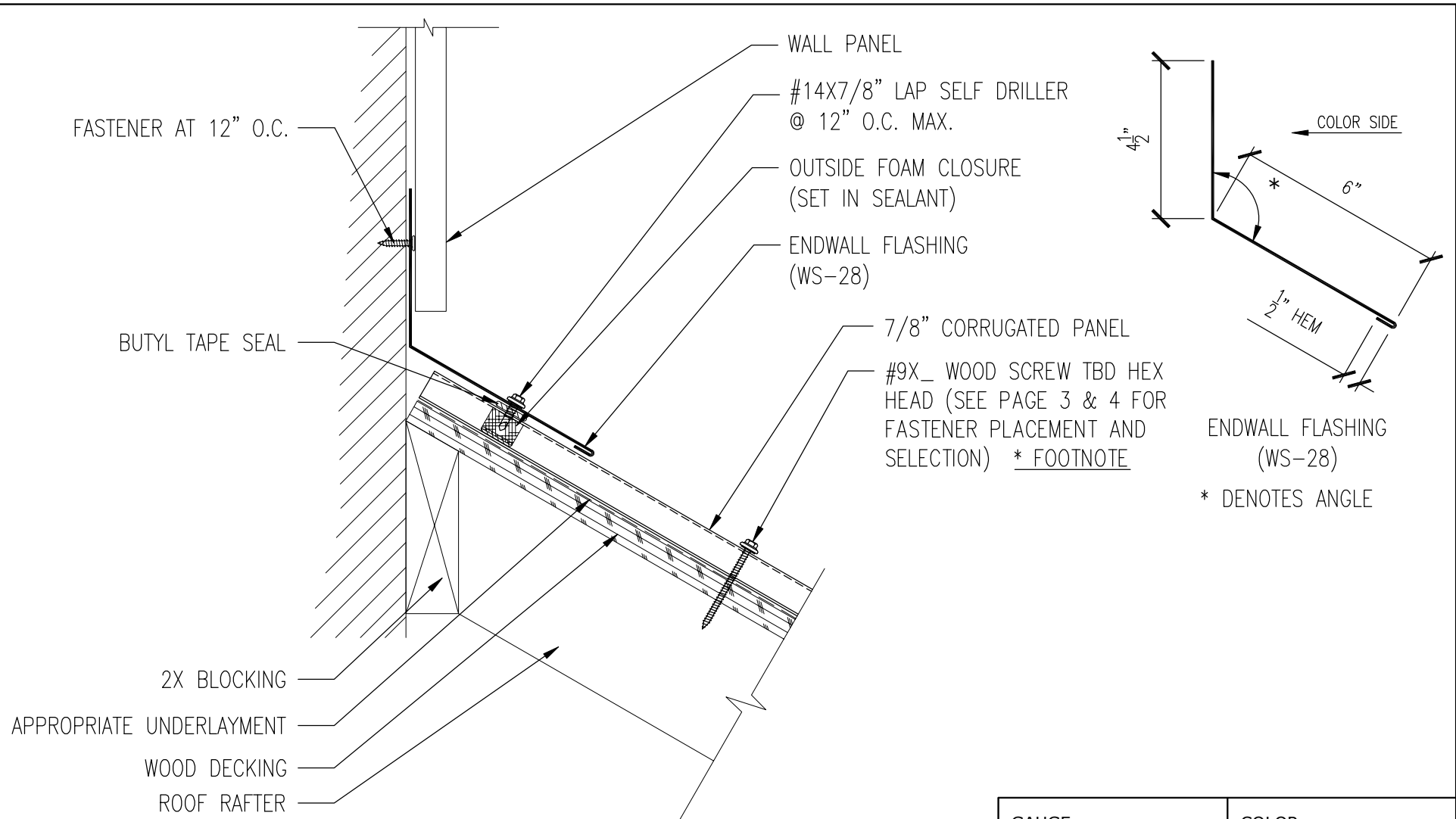

FASTENER AT 12" O.C.

WALL PANEL  
 #14X7/8" LAP SELF DRILLER  
 @ 12" O.C. MAX.

OUTSIDE FOAM CLOSURE  
 (SET IN SEALANT)

ENDWALL FLASHING  
 (WS-28)

7/8" CORRUGATED PANEL  
 #9X\_ WOOD SCREW TBD HEX  
 HEAD (SEE PAGE 3 & 4 FOR  
 FASTENER PLACEMENT AND  
 SELECTION) \* FOOTNOTE

BUTYL TAPE SEAL

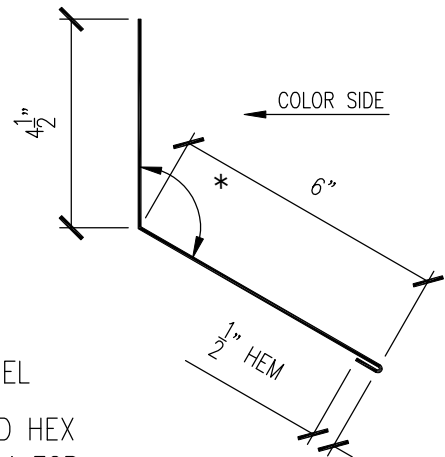

ENDWALL FLASHING  
 (WS-28)

\* DENOTES ANGLE

2X BLOCKING

APPROPRIATE UNDERLAYMENT

WOOD DECKING

ROOF RAFTER

\* FOOTNOTE:  
 FASTENER TYPE OVER PURLINS  
 TO BE #12X SELF DRILLER  
 FASTENER

GAUGE: _____	COLOR: _____
BREAKS: _____	FINISH: _____
LENGTH: _____	STRETCH OUT: _____
MATERIAL: _____	

## Western States Metal Roofing

901 W. Watkins St.  
 Phoenix, AZ 85007  
[www.MetalForRoofing.com](http://www.MetalForRoofing.com)  
[www.RustedRoofing.com](http://www.RustedRoofing.com)  
[www.MetalDeck.com](http://www.MetalDeck.com)

Phone: (602) 495-0048  
 Fax: (602) 261-7726  
 877-PURLINS (787-5467)

ENDWALL FLASHING DETAIL	B	01-14-13
	A	06-01-12
PANEL TYPE: 7/8" Corrugated	REV:	DATE:
	DETAIL #: WSD-EW5	

\* 6:12 PITCH MAX.

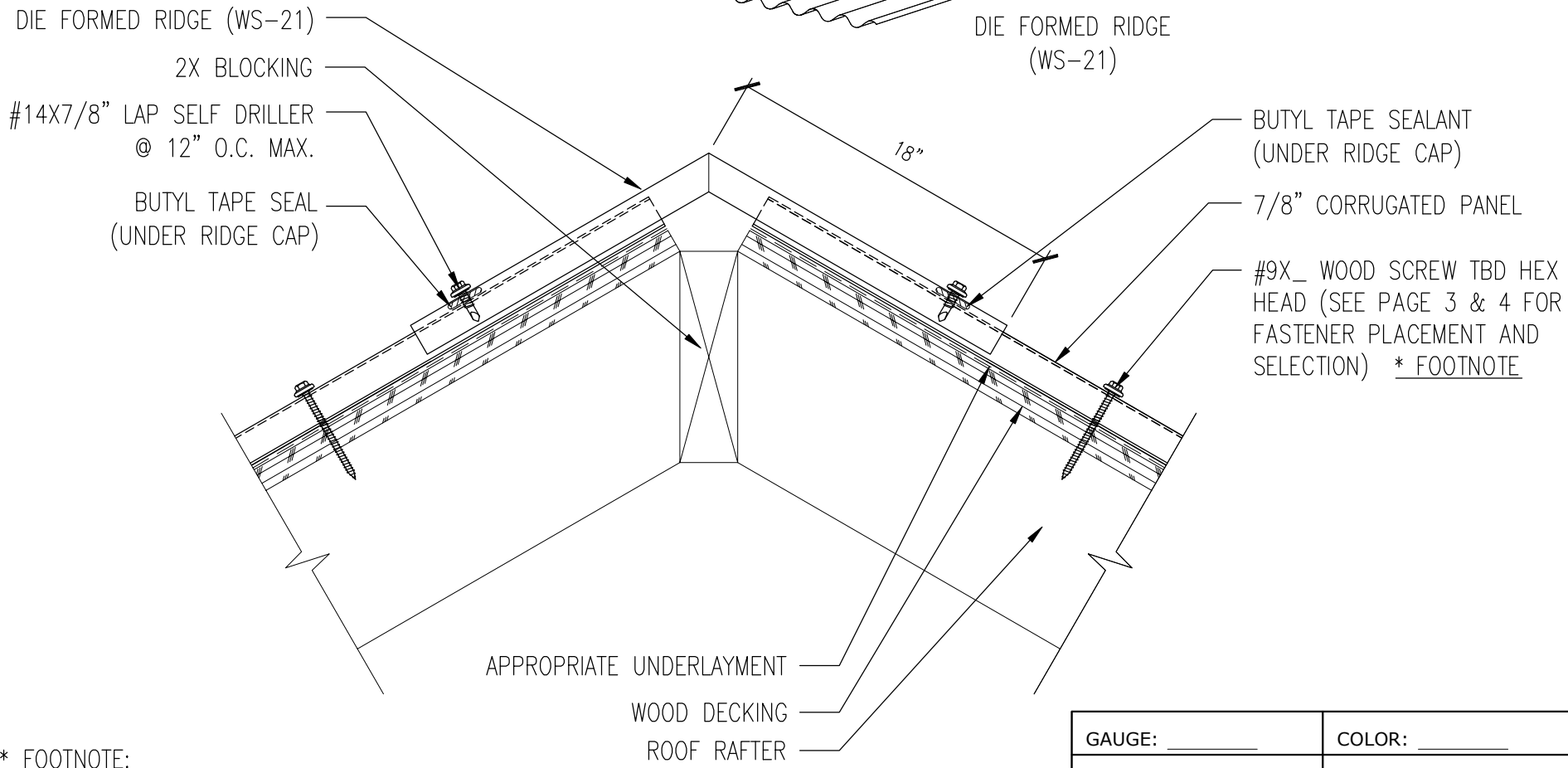

\* FOOTNOTE:  
FASTENER TYPE OVER PURLINS  
TO BE #12X SELF DRILLER  
FASTENER

GAUGE: _____	COLOR: _____
BREAKS: _____	FINISH: _____
LENGTH: _____	STRETCH OUT: _____
MATERIAL: _____	

**Western States Metal Roofing**  
 901 W. Watkins St. Phone: (602) 495-0048  
 Phoenix, AZ 85007 Fax: (602) 261-7726  
 www.MetalForRoofing.com 877-PURLINS (787-5467)  
 www.RustedRoofing.com  
 www.MetalDeck.com

<b>FORMED RIDGE DETAIL</b>	B	01-14-13
	A	06-01-12
PANEL TYPE: <b>7/8" Corrugated</b>	REV:	DATE:
	DETAIL #: <b>WSD-FR6</b>	

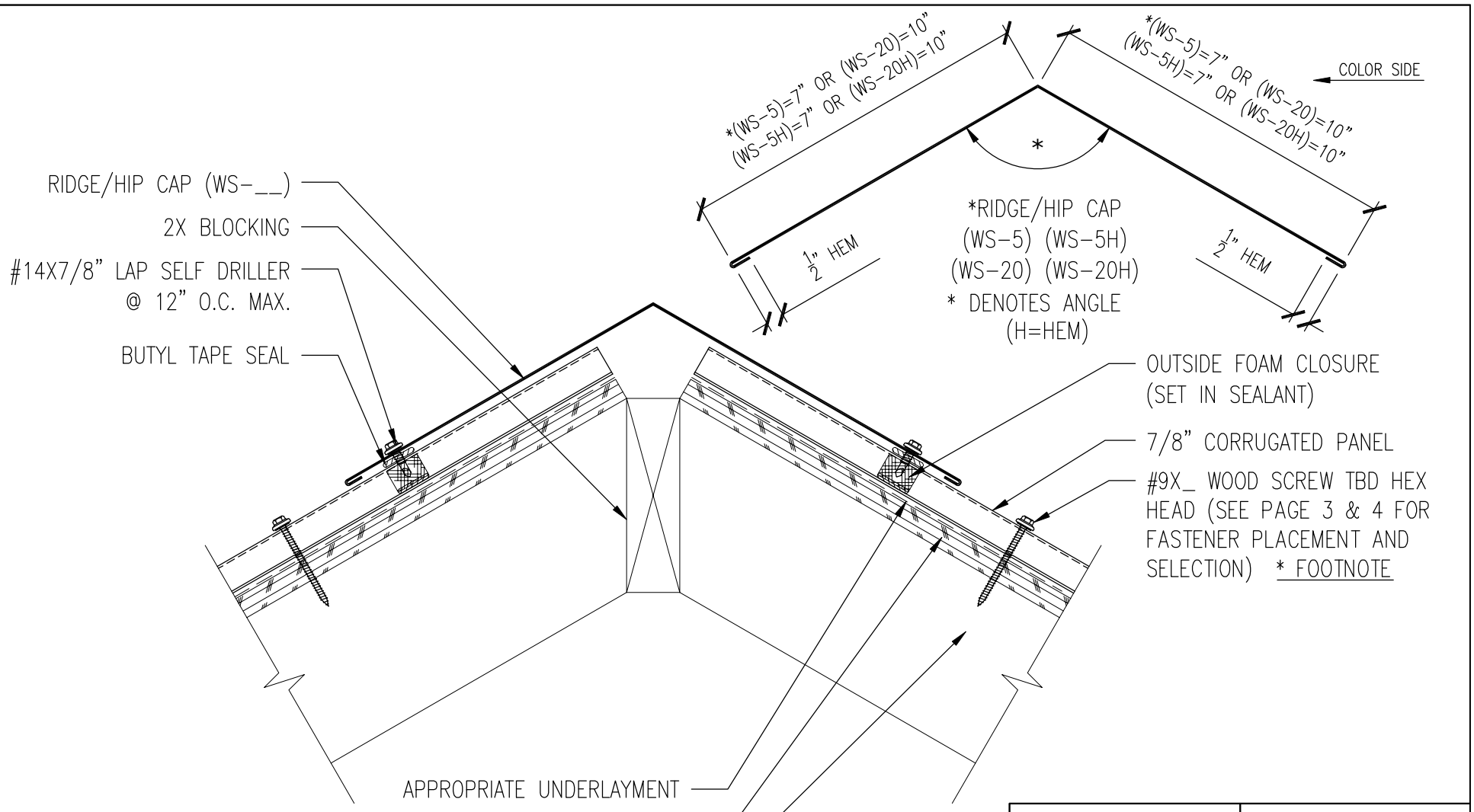

RIDGE/HIP CAP (WS-\_\_\_)  
 2X BLOCKING  
 #14X7/8" LAP SELF DRILLER  
 @ 12" O.C. MAX.  
 BUTYL TAPE SEAL

\* (WS-5)=7" OR (WS-20)=10"  
 (WS-5H)=7" OR (WS-20H)=10"  
 \* (WS-5)=7" OR (WS-20)=10"  
 (WS-5H)=7" OR (WS-20H)=10"  
 \*RIDGE/HIP CAP  
 (WS-5) (WS-5H)  
 (WS-20) (WS-20H)  
 \* DENOTES ANGLE  
 (H=HEM)  
 1/2" HEM  
 1/2" HEM  
 COLOR SIDE

OUTSIDE FOAM CLOSURE  
 (SET IN SEALANT)  
 7/8" CORRUGATED PANEL  
 #9X\_ WOOD SCREW TBD HEX  
 HEAD (SEE PAGE 3 & 4 FOR  
 FASTENER PLACEMENT AND  
 SELECTION) \* FOOTNOTE

APPROPRIATE UNDERLAYMENT  
 WOOD DECKING  
 ROOF RAFTER

\* FOOTNOTE:  
 FASTENER TYPE OVER PURLINS  
 TO BE #12X SELF DRILLER  
 FASTENER

GAUGE: _____	COLOR: _____
BREAKS: _____	FINISH: _____
LENGTH: _____	STRETCH OUT: _____
MATERIAL: _____	

## Western States Metal Roofing

901 W. Watkins St. Phone: (602) 495-0048  
 Phoenix, AZ 85007 Fax: (602) 261-7726  
 www.MetalForRoofing.com 877-PURLINS (787-5467)  
 www.RustedRoofing.com  
 www.MetalDeck.com

RIDGE/HIP CAP DETAIL	B	01-14-13
	A	06-01-12
PANEL TYPE: 7/8" Corrugated	REV:	DATE:
	DETAIL #: WSD-RH6	

\*VALLEY FLASHING  
(WS-23, WS-24, WS-25)

\* DENOTES ANGLE

COLOR SIDE

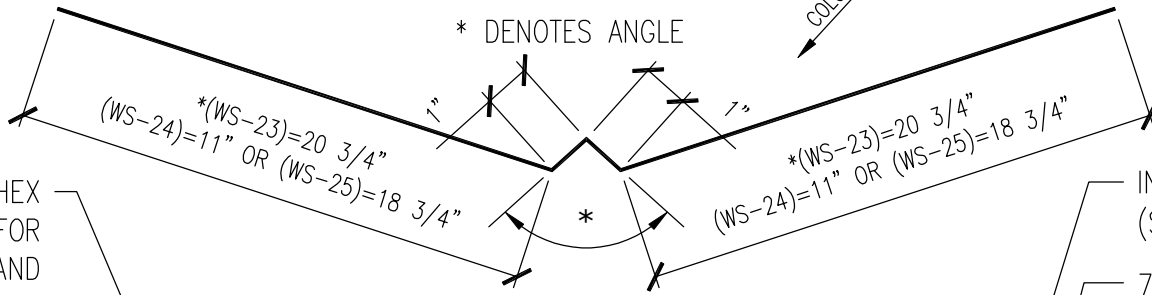

#9X\_ WOOD SCREW TBD HEX HEAD (SEE PAGE 3 & 4 FOR FASTENER PLACEMENT AND SELECTION) \* FOOTNOTE

NOTE:  
ICE AND WATER SHIELD 3' EACH SIDE  
AVALANCHE VALLEY FOR HIGH SNOW  
AND ICE AREAS

INSIDE FOAM CLOSURE  
(SET IN SEALANT)

7/8" CORRUGATED PANEL

\*VALLEY FLASHING (WS-\_\_)

FASTENER AT 12" O.C.

\* FOOTNOTE:  
FASTENER TYPE OVER PURLINS TO BE  
#12X SELF DRILLER FASTENER  
  
16GA VALLEY SUPPORT PLATE REQUIRED  
WHEN INSTALLED OVER PURLINS

APPROPRIATE UNDERLAYMENT

WOOD DECKING

ROOF RAFTER

GAUGE: _____	COLOR: _____
BREAKS: _____	FINISH: _____
LENGTH: _____	STRETCH OUT: _____
MATERIAL: _____	

## Western States Metal Roofing

901 W. Watkins St.  
Phoenix, AZ 85007  
www.MetalForRoofing.com  
www.RustedRoofing.com  
www.MetalDeck.com

Phone: (602) 495-0048  
Fax: (602) 261-7726  
877-PURLINS (787-5467)

VALLEY DETAIL	B	01-14-13
	A	06-01-12
PANEL TYPE: 7/8" Corrugated	REV:	DATE:
	DETAIL #: WSD-V7	



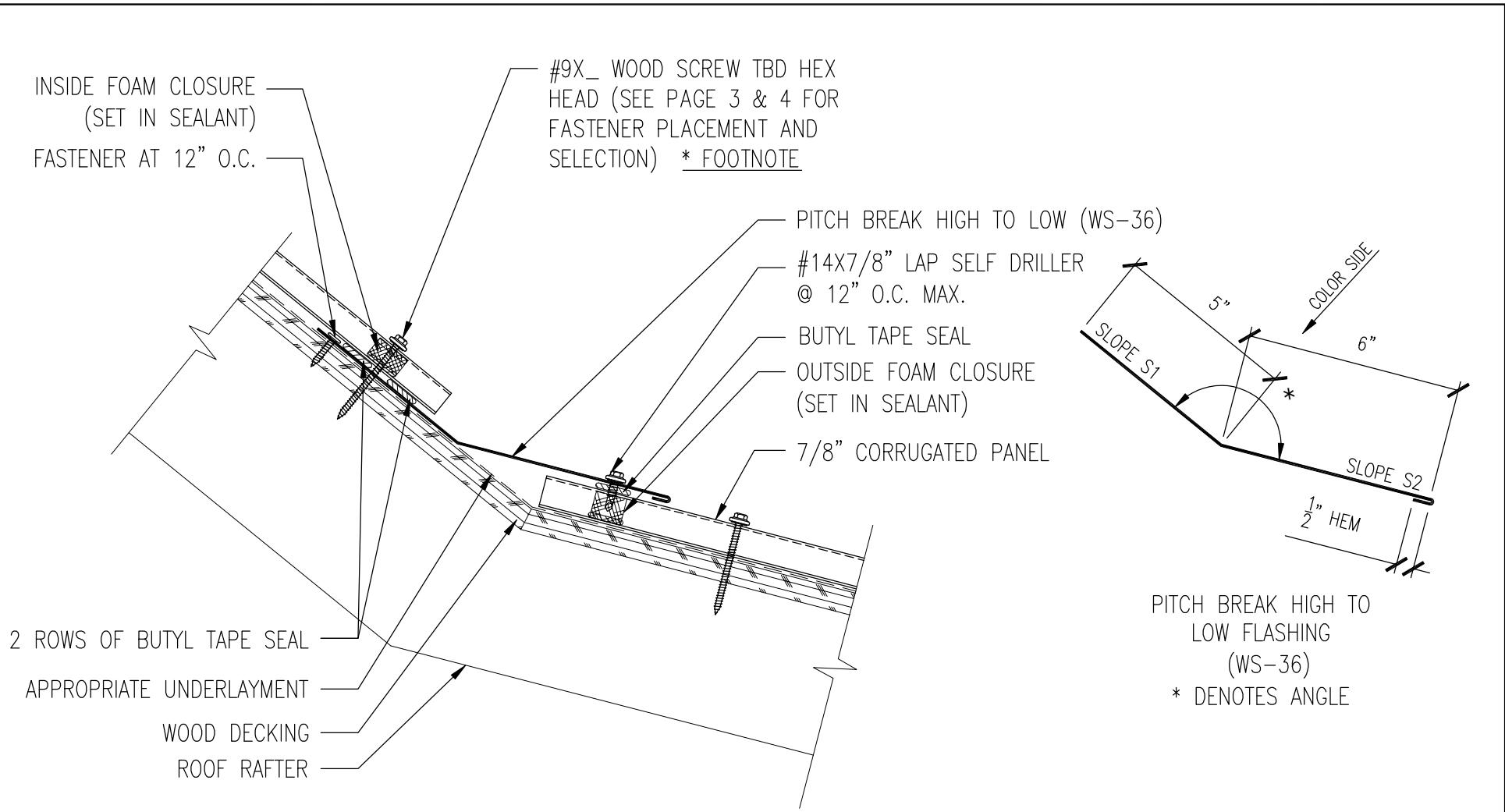

\* FOOTNOTE:  
FASTENER TYPE OVER PURLINS  
TO BE #12X SELF DRILLER  
FASTENER

GAUGE: _____	COLOR: _____
BREAKS: _____	FINISH: _____
LENGTH: _____	STRETCH OUT: _____
MATERIAL: _____	

## Western States Metal Roofing

901 W. Watkins St.  
Phoenix, AZ 85007  
www.MetalForRoofing.com  
www.RustedRoofing.com  
www.MetalDeck.com

Phone: (602) 495-0048  
Fax: (602) 261-7726  
877-PURLINS (787-5467)

PITCH BREAK HIGH TO LOW DETAIL	B	01-14-13
	A	06-01-12
PANEL TYPE: 7/8" Corrugated	REV:	DATE:
	DETAIL #: WSD-PB8	

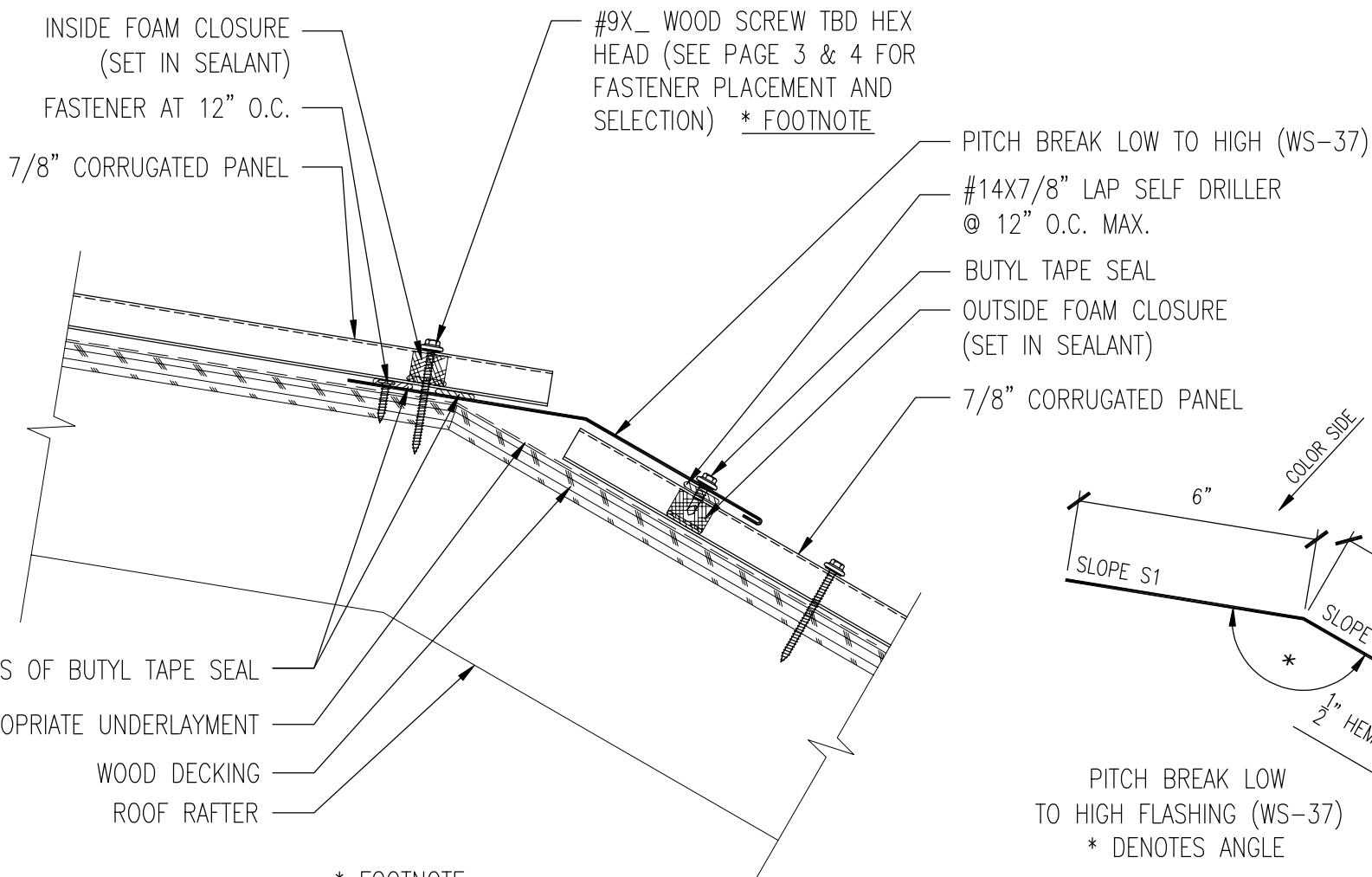

\* FOOTNOTE:  
 FASTENER TYPE OVER PURLINS  
 TO BE #12X SELF DRILLER  
 FASTENER

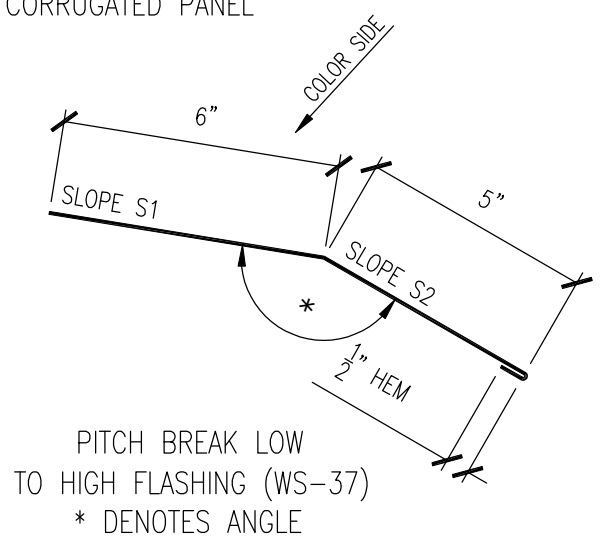

PITCH BREAK LOW  
 TO HIGH FLASHING (WS-37)  
 \* DENOTES ANGLE

GAUGE: _____	COLOR: _____
BREAKS: _____	FINISH: _____
LENGTH: _____	STRETCH OUT: _____
MATERIAL: _____	

## Western States Metal Roofing

901 W. Watkins St.  
 Phoenix, AZ 85007  
[www.MetalForRoofing.com](http://www.MetalForRoofing.com)  
[www.RustedRoofing.com](http://www.RustedRoofing.com)  
[www.MetalDeck.com](http://www.MetalDeck.com)

Phone: (602) 495-0048  
 Fax: (602) 261-7726  
 877-PURLINS (787-5467)

PITCH BREAK LOW TO HIGH DETAIL	B	01-14-13
	A	06-01-12
PANEL TYPE: 7/8" Corrugated	REV:	DATE:
	DETAIL #: WSD-PB9	

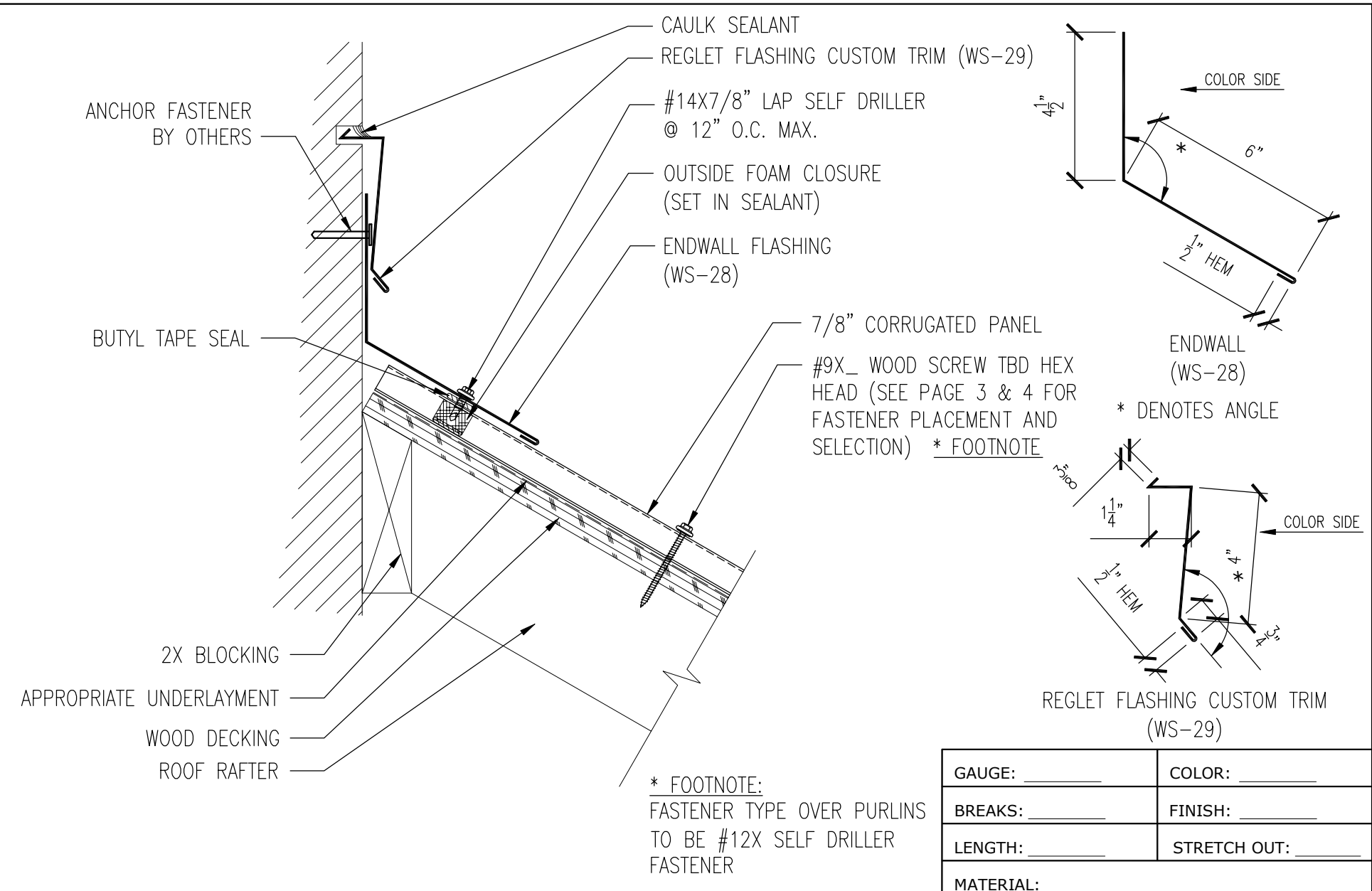

**Western States Metal Roofing**  
 901 W. Watkins St. Phone: (602) 495-0048  
 Phoenix, AZ 85007 Fax: (602) 261-7726  
 www.MetalForRoofing.com 877-PURLINS (787-5467)  
 www.RustedRoofing.com  
 www.MetalDeck.com

GAUGE: _____	COLOR: _____
BREAKS: _____	FINISH: _____
LENGTH: _____	STRETCH OUT: _____
MATERIAL: _____	
<b>CHIMNEY FLASHING DETAILS</b>	B 01-14-13
	A 06-01-12
PANEL TYPE: <b>7/8" Corrugated</b>	REV: _____ DATE: _____
DETAIL #: <b>WSD-CF10</b>	

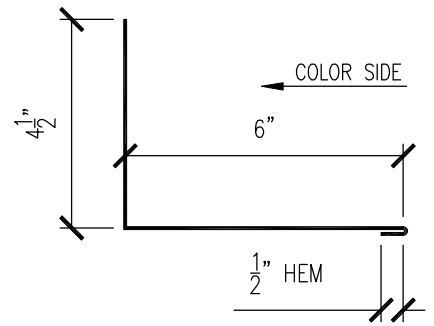
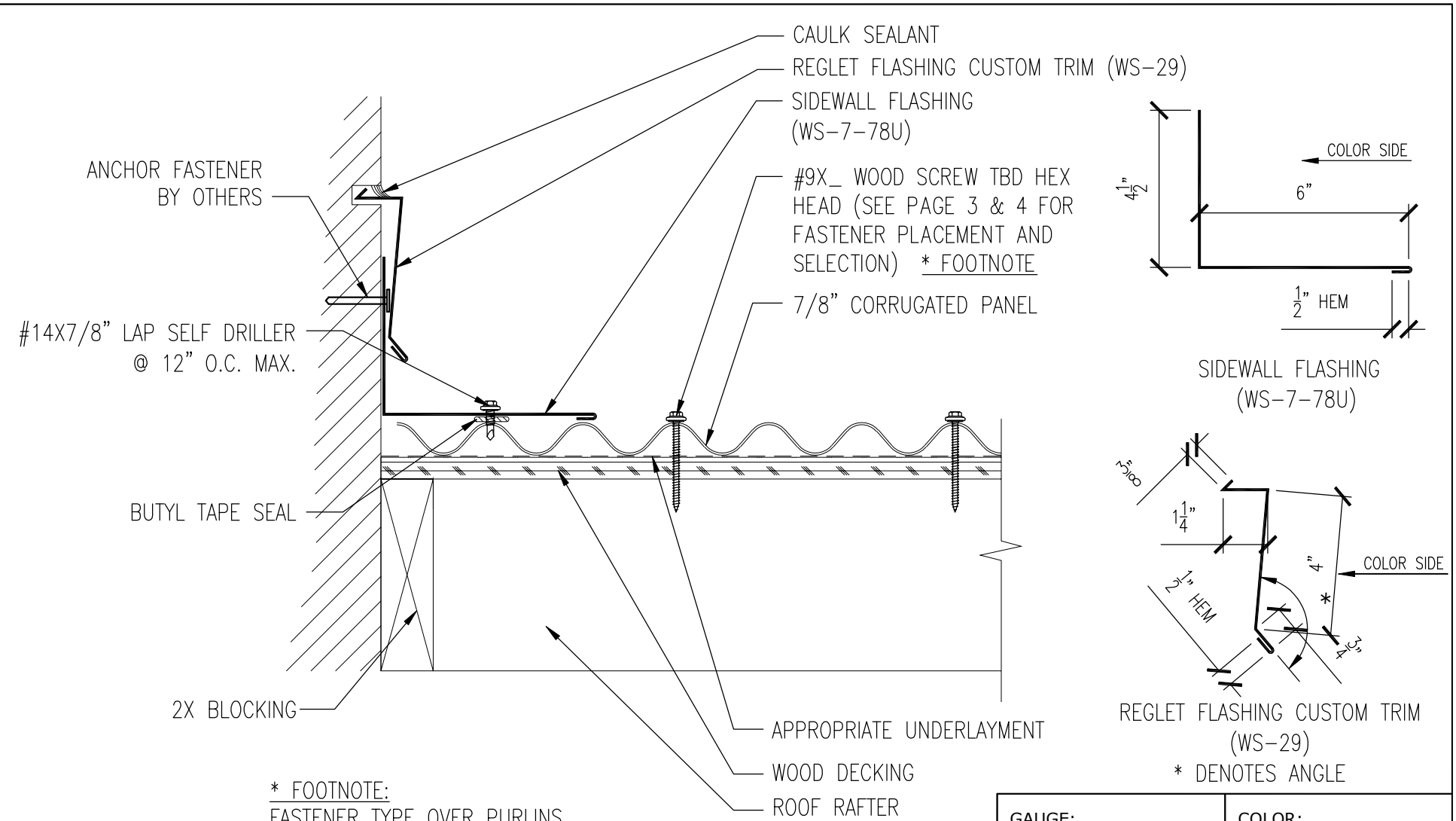

SIDEWALL FLASHING (WS-7-78U)

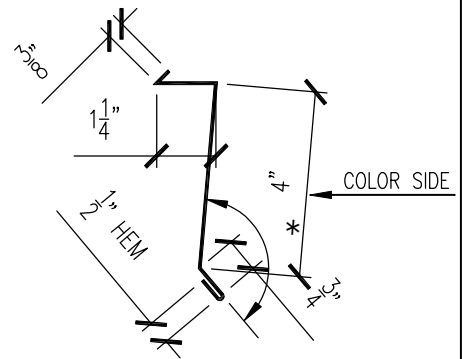

REGLET FLASHING CUSTOM TRIM (WS-29)

\* DENOTES ANGLE

\* FOOTNOTE:  
FASTENER TYPE OVER PURLINS  
TO BE #12X SELF DRILLER  
FASTENER

GAUGE: _____	COLOR: _____
BREAKS: _____	FINISH: _____
LENGTH: _____	STRETCH OUT: _____
MATERIAL: _____	

## Western States Metal Roofing

901 W. Watkins St.  
Phoenix, AZ 85007  
www.MetalForRoofing.com  
www.RustedRoofing.com  
www.MetalDeck.com

Phone: (602) 495-0048  
Fax: (602) 261-7726  
877-PURLINS (787-5467)

CHIMNEY FLASHING DETAILS	B	01-14-13
	A	06-01-12
PANEL TYPE: 7/8" Corrugated	REV:	DATE:
	DETAIL #:	WSD-CF11

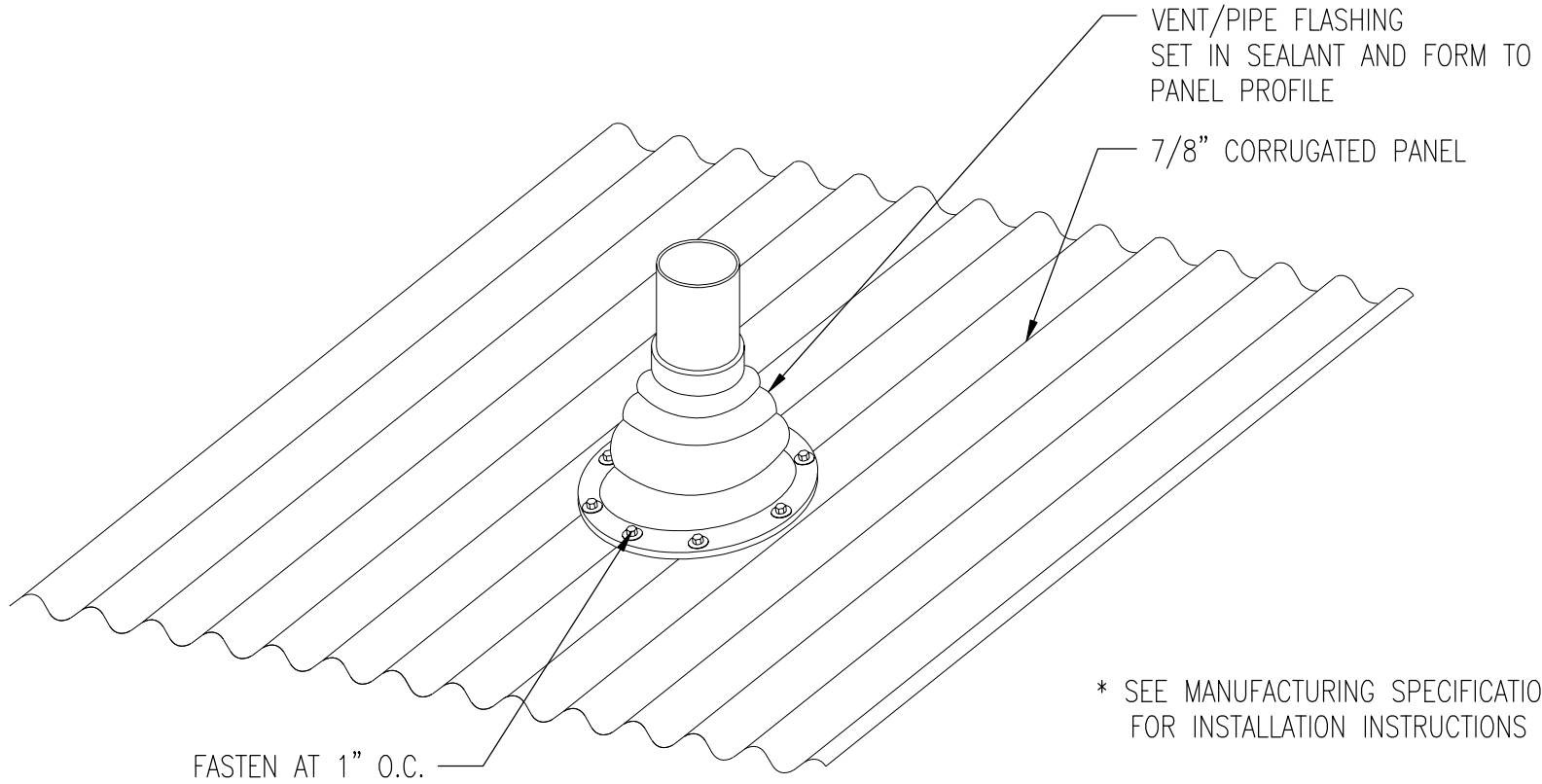

\* SEE MANUFACTURING SPECIFICATIONS FOR INSTALLATION INSTRUCTIONS

GAUGE: _____	COLOR: _____
BREAKS: _____	FINISH: _____
LENGTH: _____	STRETCH OUT: _____
MATERIAL: _____	

## Western States Metal Roofing

901 W. Watkins St.  
 Phoenix, AZ 85007  
[www.MetalForRoofing.com](http://www.MetalForRoofing.com)  
[www.RustedRoofing.com](http://www.RustedRoofing.com)  
[www.MetalDeck.com](http://www.MetalDeck.com)

Phone: (602) 495-0048  
 Fax: (602) 261-7726  
 877-PURLINS (787-5467)

PIPE FLASHING DETAIL	B	01-14-13
	A	06-01-12
PANEL TYPE: 7/8" Corrugated	REV:	DATE:
	DETAIL #: WSD-PF12	

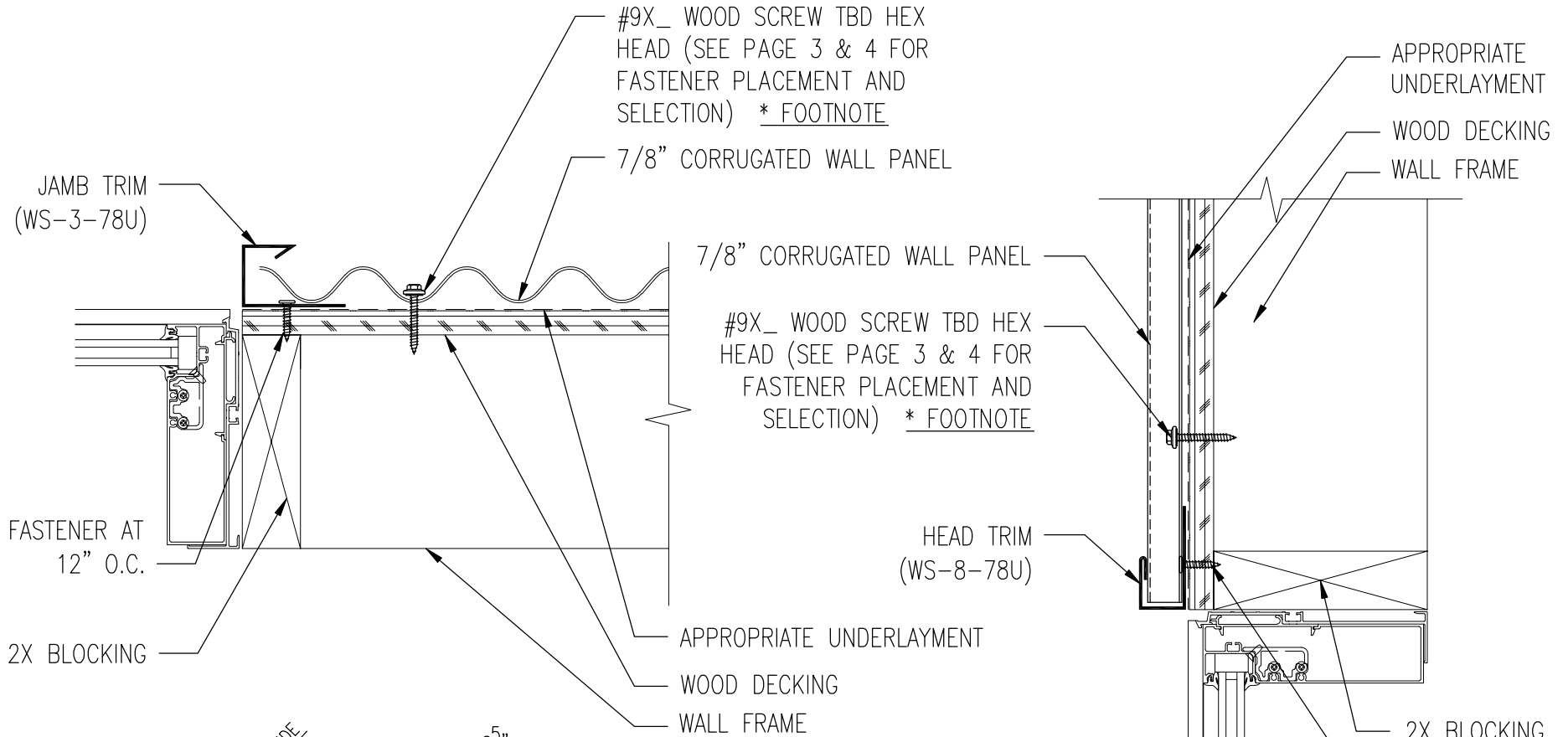

\* FOOTNOTE:  
FASTENER TYPE OVER PURLINS  
TO BE #12X\_ SELF DRILLER  
FASTENER

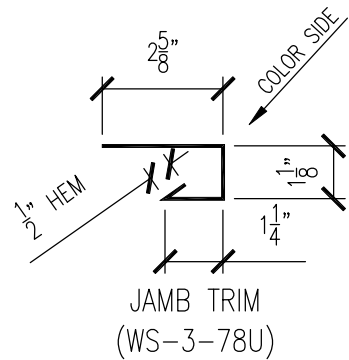

JAMB TRIM  
(WS-3-78U)

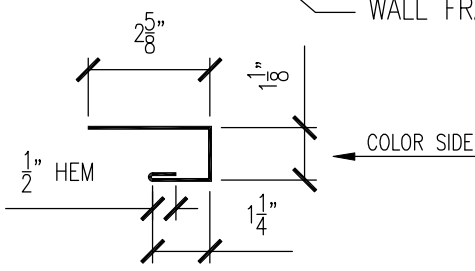

HEAD TRIM  
(WS-8-78U)

GAUGE: _____	COLOR: _____
BREAKS: _____	FINISH: _____
LENGTH: _____	STRETCH OUT: _____
MATERIAL: _____	

## Western States Metal Roofing

901 W. Watkins St.  
Phoenix, AZ 85007  
www.MetalForRoofing.com  
www.RustedRoofing.com  
www.MetalDeck.com

Phone: (602) 495-0048  
Fax: (602) 261-7726  
877-PURLINS (787-5467)

HEAD AND JAMB DETAILS	B	01-14-13
	A	06-01-12
PANEL TYPE: 7/8" Corrugated	REV:	DATE:
	DETAIL #: WSD-W13	

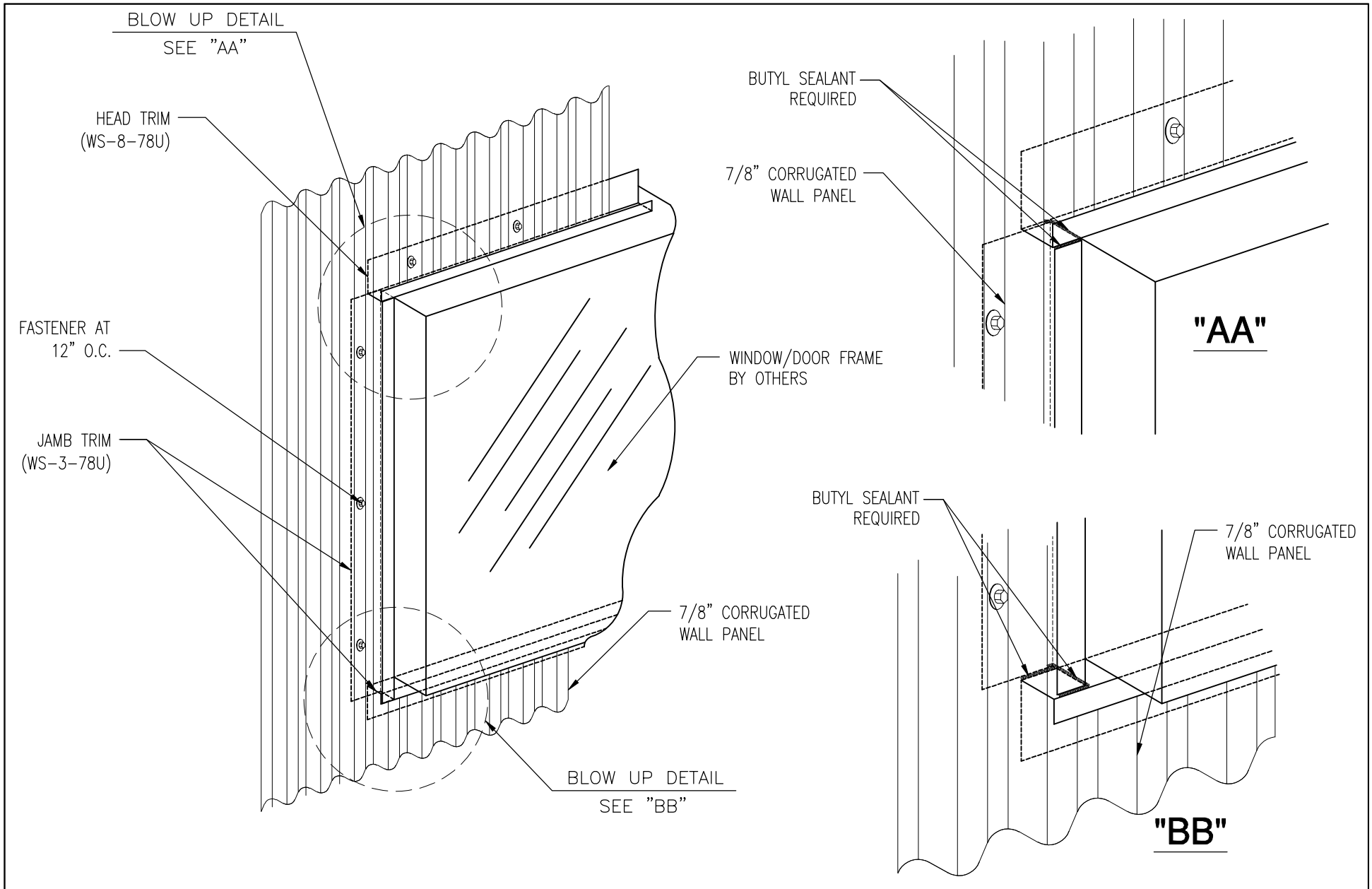

# Western States Metal Roofing

901 W. Watkins St.  
 Phoenix, AZ 85007  
[www.MetalForRoofing.com](http://www.MetalForRoofing.com)  
[www.RustedRoofing.com](http://www.RustedRoofing.com)  
[www.MetalDeck.com](http://www.MetalDeck.com)

Phone: (602) 495-0048  
 Fax: (602) 261-7726  
 877-PURLINS (787-5467)

<b>ISOMETRIC WALL DETAIL</b>	B	01-14-13
	A	06-01-12
PANEL TYPE: <b>7/8" Corrugated</b>	REV:	DATE:
	DETAIL #: <b>WSD-W14</b>	

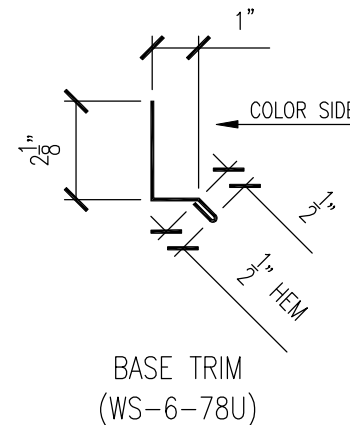
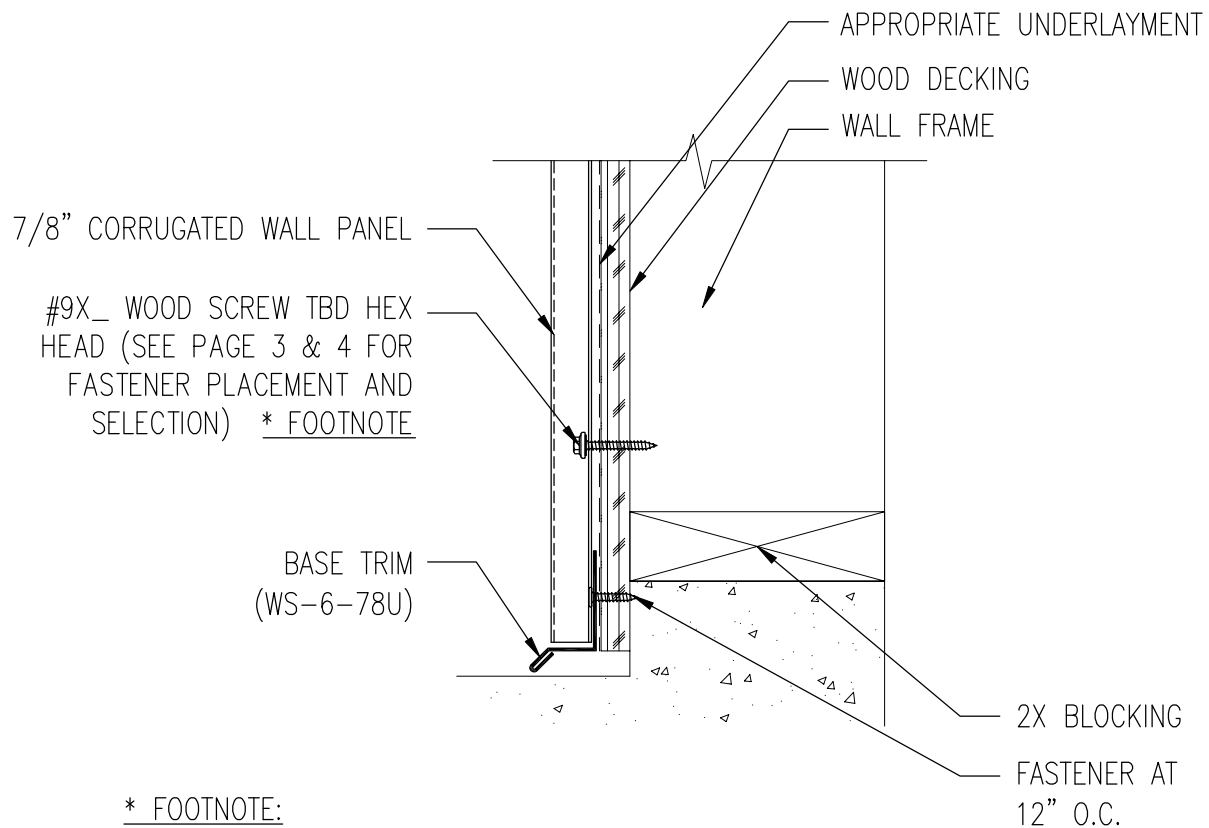

\* FOOTNOTE:  
FASTENER TYPE OVER PURLINS  
TO BE #12X SELF DRILLER  
FASTENER

GAUGE: _____	COLOR: _____
BREAKS: _____	FINISH: _____
LENGTH: _____	STRETCH OUT: _____
MATERIAL: _____	

## Western States Metal Roofing

901 W. Watkins St.  
Phoenix, AZ 85007  
www.MetalForRoofing.com  
www.RustedRoofing.com  
www.MetalDeck.com

Phone: (602) 495-0048  
Fax: (602) 261-7726  
877-PURLINS (787-5467)

BASE DETAIL	B	01-14-13
	A	06-01-12
PANEL TYPE: 7/8" Corrugated	REV:	DATE:
	DETAIL #: WSD-W15	



#14X7/8" LAP SELF DRILLER  
@ 12" O.C. MAX.

BUTYL TAPE SEAL

\*OUTSIDE CORNER  
(WS-\_\_\_-UOC)

#9X\_ WOOD SCREW TBD HEX  
HEAD (SEE PAGE 3 & 4 FOR  
FASTENER PLACEMENT AND  
SELECTION) \* FOOTNOTE

7/8" CORRUGATED WALL PANEL

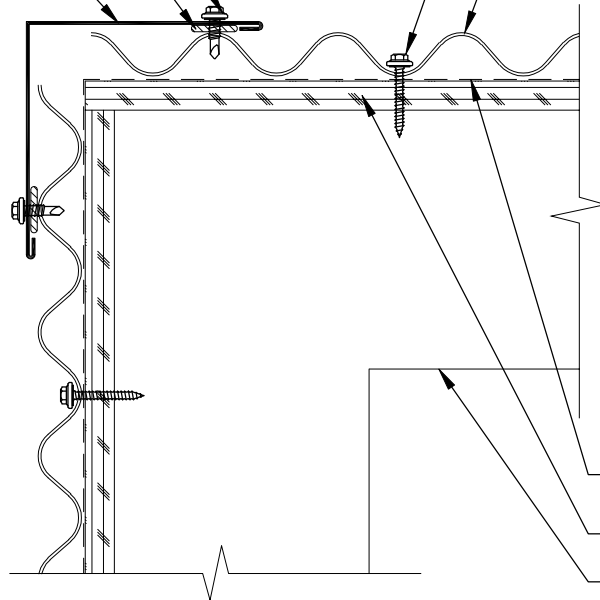

APPROPRIATE UNDERLAYMENT

WOOD DECKING

WALL FRAME

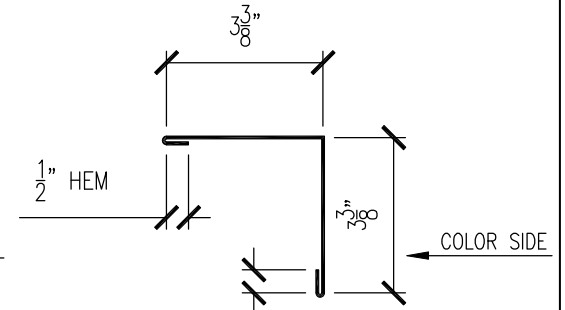

\*OUTSIDE CORNER  
(WS-47-UOC)

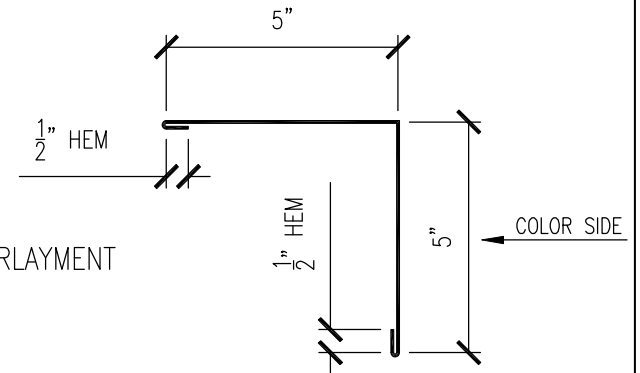

\*OUTSIDE CORNER  
(WS-55-UOC)

\* FOOTNOTE:  
FASTENER TYPE OVER PURLINS  
TO BE #12X SELF DRILLER  
FASTENER

GAUGE: _____	COLOR: _____
BREAKS: _____	FINISH: _____
LENGTH: _____	STRETCH OUT: _____
MATERIAL: _____	

## Western States Metal Roofing

901 W. Watkins St.  
Phoenix, AZ 85007  
www.MetalForRoofing.com  
www.RustedRoofing.com  
www.MetalDeck.com

Phone: (602) 495-0048  
Fax: (602) 261-7726  
877-PURLINS (787-5467)

OUTSIDE CORNER  
WALL DETAIL

B 01-14-13

A 06-01-12

REV: DATE:

PANEL TYPE:

7/8" Corrugated

DETAIL #:  
WSD-W16

#9X\_ WOOD SCREW TBD HEX HEAD (SEE PAGE 3 & 4 FOR FASTENER PLACEMENT AND SELECTION) \* FOOTNOTE

BUTYL TAPE SEAL  
 #14X7/8" LAP SELF DRILLER @ 12" O.C. MAX.  
 INSIDE CORNER (WS-56-UIC)  
 7/8" CORRUGATED WALL PANEL  
 APPROPRIATE UNDERLAYMENT  
 WOOD DECKING  
 WALL FRAME

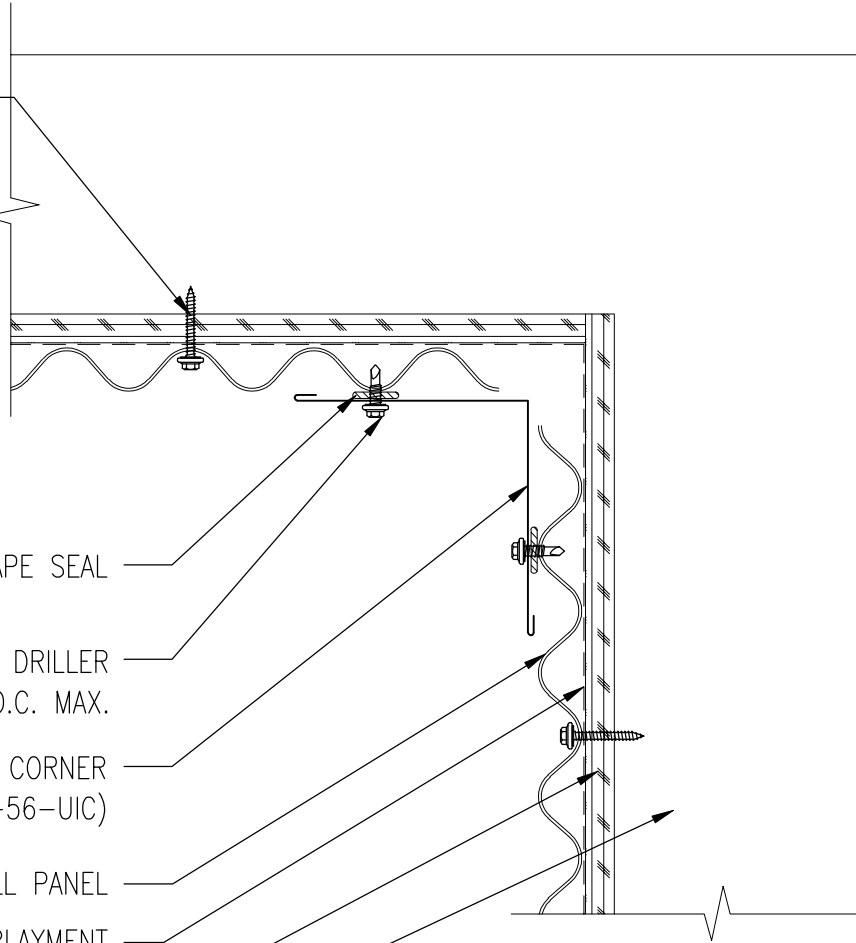

\* FOOTNOTE:  
 FASTENER TYPE OVER PURLINS TO BE #12X SELF DRILLER FASTENER

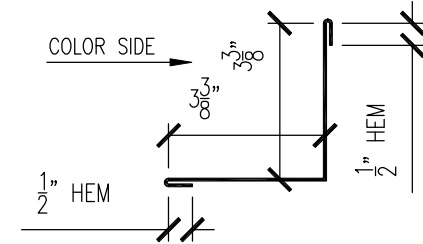

\*INSIDE CORNER (WS-46-UIC)

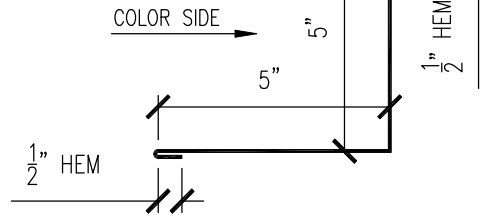

\*INSIDE CORNER (WS-56-UIC)

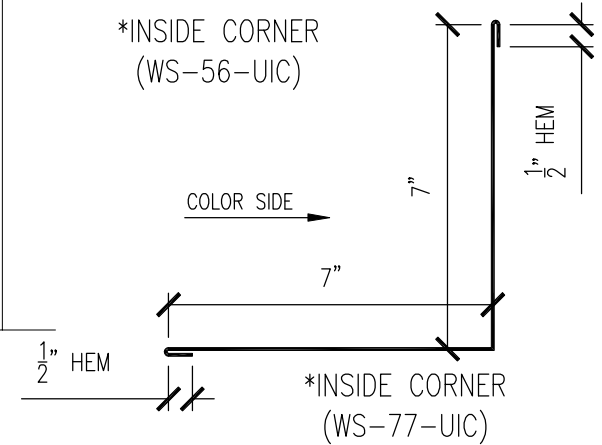

\*INSIDE CORNER (WS-77-UIC)

GAUGE: _____	COLOR: _____
BREAKS: _____	FINISH: _____
LENGTH: _____	STRETCH OUT: _____
MATERIAL: _____	

## Western States Metal Roofing

901 W. Watkins St.  
 Phoenix, AZ 85007  
[www.MetalForRoofing.com](http://www.MetalForRoofing.com)  
[www.RustedRoofing.com](http://www.RustedRoofing.com)  
[www.MetalDeck.com](http://www.MetalDeck.com)

Phone: (602) 495-0048  
 Fax: (602) 261-7726  
 877-PURLINS (787-5467)

INSIDE CORNER WALL DETAIL	B	01-14-13
	A	06-01-12
PANEL TYPE: 7/8" Corrugated	REV:	DATE:
	DETAIL #: WSD-W17	

# NOTES:

## Western States Metal Roofing

901 W. Watkins St.  
Phoenix, AZ 85007  
[www.MetalForRoofing.com](http://www.MetalForRoofing.com)  
[www.RustedRoofing.com](http://www.RustedRoofing.com)  
[www.MetalDeck.com](http://www.MetalDeck.com)

Phone: (602) 495-0048  
Fax: (602) 261-7726  
877-PURLINS (787-5467)

NOTES

PANEL TYPE:

7/8" Corrugated

B 01-14-13

A 06-01-12

REV: DATE:

DETAIL #:  
WSD-MN18

# CUSTOM TRIM

GAUGE: _____	COLOR: _____	
BREAKS: _____	FINISH: _____	
LENGTH: _____	STRETCH OUT: _____	
MATERIAL: _____		
CUSTOM TRIM NAME: _____	B	01-14-13
	A	06-01-12
PANEL TYPE: <b>7/8" Corrugated</b>	REV:	DATE:
	DETAIL #: <b>WSD-CT19</b>	

## Western States Metal Roofing

901 W. Watkins St.  
Phoenix, AZ 85007  
[www.MetalForRoofing.com](http://www.MetalForRoofing.com)  
[www.RustedRoofing.com](http://www.RustedRoofing.com)  
[www.MetalDeck.com](http://www.MetalDeck.com)

Phone: (602) 495-0048  
Fax: (602) 261-7726  
877-PURLINS (787-5467)

## Western States 7/8" Corrugated Panel

Installation, Flashings & Shop Drawing Detail Guide

### Special Design Considerations

The details contained in this guide are proven industry details and are intended to be used as a design aid and installation guide. It does not depict all situations that may be encountered on all projects. Modifications are the responsibility of the designer/ owner/ installer.

Consideration should be given for Fit for Purpose, Building use, Climate conditions such as temperature, snow, wind, and moisture, Governing Building Codes, and Maintenance.

It is highly recommended that all trims and flashings be of the same material as the panels (metal, gauge, finish) to ensure long term performance and durability. Where possible, flashing edges should be hemmed to strengthen the edge and protect the cut edge from exposure.

### Acceptance

**Use of this manual is strictly voluntary.** Details that are provided are to be used as a guide only. Details may not be applicable for all situations. This guide provides one standard detail and WSDI accepts that other installation details may be needed and other details may exist. WSDI makes no guarantee as to the Weather Tightness of the system or details found with in this guide. The information in this manual is believed to be correct and accurate at the time of printing. WSDI reserves the right to change details, discontinue products, change designs at any time without incurring obligation. It is best to consult your Design Engineer for recommendations.

### Underlayment

There are many types of underlayment's on the market today. All designed with a special purpose depending on the type of Metal and profile. Many different types of metal will require a different type of underlayment, such as A606-4 (Corten) which requires a High Temperature underlayment. It is best to consult your Design Engineer for recommendations.

### Valley and Snow Design

Valley design and dimension must be the proper width to accommodate high snow, rain, ice, and slope conditions. If possible, splices, penetrations, valleys, roof elevation changes, should be minimized in areas of high snow and ice accumulations. Details found in this manual may not pertain in areas of high snow and ice accumulations.

### Panel coverage and fastening

Normal panel width of 7/8" corrugated panel is 36". However depending on the finish selected and the required coil feed, it may be necessary for WSDI to shorten the width of the panel. Please consult with your WSDI representative for details and fastening recommendations.

### Safety and Maintenance

Walking on and installing any roof is dangerous! Extreme care should always be used when walking on roofs. Safety should always be a top priority and approved fall protection and equipment as approved by OSHA should always be used.

No roof is immune to severe weather or is completely maintenance free. To keep your roof performing as it was designed; an inspection and comprehensive maintenance program should be implemented.

### References

For other installation techniques and details, The Sheet Metal and Air Conditioning Contractors National Association Inc. (SMACNA) and NRCA manuals are great resources for working with sheet metal.

### Technical Assistance

Contact your WSDI sales or technical representative for any additional information or assistance. To insure you have the latest information available, please inquire or visit our web sites at [www.metaldeck.com](http://www.metaldeck.com) or [Rustedroofing.com](http://Rustedroofing.com)

**WESTERN STATES  
METAL ROOFING**



Office:  
Western States Metal Roofing  
901 W. Watkins Street  
Phoenix, AZ 85007

Phone:  
(877) 787-5467  
(855) 426-7836

Email:  
[sales@cortenroofing.com](mailto:sales@cortenroofing.com)  
[sales@metalforroofing.com](mailto:sales@metalforroofing.com)

For More Information:  
[www.cortenroofing.com](http://www.cortenroofing.com)  
[www.metalforroofing.com](http://www.metalforroofing.com)