

BERTRAM 58

CONVERTIBLE

A WORD OF WELCOME

We are please that you have chosen a Bertram, and know that her unique design will give you outstanding performance and many years of boating pleasure.

Your Bertram is built of the finest, most modern materials and is manufactured under rigid quality controls. Her hull is of high-impact, multi-laminate fiberglass. Her deck and cabin is of welded marine aluminum with thermal insulation. High pressure laminates and vinyl throughout further reduce maintenance. She comes to you as the most thoroughly tested and trouble-free boat on the market today.

As durable as her construction is, your Bertram will benefit with reasonable care. And, as is always true with things mechanical, maintenance, adjustments, or repairs may be required from time to time for certain components. Thus, this Owner's Manual, containing a wealth of detailed information, has been specially prepared for your particular model to guide you in keeping her in yacht condition.

To fully enjoy your Bertram, you should understand her competely. To this end, we suggest that you read this manual thoroughly. If any points arise that you do not completely understand, your Bertram Dealer will be glad to assist you. Included are warranties, ours and those of manufacturers of engines and accessories.

When your boat requires service, contact your Bertram dealer. He has been factory trained to help you and our factory service representatives are available to help him if need be.

We wish you many years of pleasurable yachting on your new Bertram.

TABLE OF CONTENTS

| | |
|---|-----------|
| Welcome | PREFACE |
| Data Sheet | |
| Technical Data, Main Engines Main Generator Auxiliary Generator | |
| <u>CONTENTS</u> | Section A |
| Table of Contents | A-1 |
| List of Illustrations | A-2 |
| <u>CONTROLS and INSTRUMENTS</u> | Section B |
| Control Stations | B-1 |
| On-Stop & Starter Switches | B-1 |
| Accessory Switches | B-2 |
| Horn Switch | B-2 |
| Battery Paralleling Switch | B-2 |
| Importance of Instruments | B-2 |
| Gauges | B-2 |
| Ammeter | B-3 |
| Fuel Gauges | B-3 |
| Lube Oil Pressure Gauge | B-4 |
| Temperature Gauge | B-4 |
| Tachometer | B-4 |
| Drive Oil Pressure Gauge | B-4 |
| Hour Meter | B-5 |
| Water Gauges | B-5 |

| | |
|---------------------------|-----|
| Safety Alarm System | B-5 |
| Bridge Controls | B-6 |
| Clutch & Reverse Control | B-6 |
| Throttle-Governor Control | B-6 |
| Steering Control | B-6 |

PROPULSION EQUIPMENT

SECTION C

| | |
|------------------------------------|-----|
| Engines | C-1 |
| Marine Gears (Standard) | C-1 |
| Marine Gears (Optional) | |
| Propeller Shafts | C-1 |
| Shaft Alignment | C-1 |
| Shaft Log & Stuffing Box | C-2 |
| Propellers | C-3 |
| Installation of Propellers | C-3 |
| Exhaust System | C-3 |
| Boat Speed | C-4 |
| Engine Efficiency | C-4 |
| Atmospheric Conditions | C-4 |
| Personal Equipment and Accessories | C-4 |
| Testing | C-4 |
| Test Cond. I | C-5 |
| Test Cond. II | C-5 |
| Marine Growth | C-5 |
| Water in Bilge | C-5 |
| Damaged Underwater Equipment | C-5 |

ELECTRICAL EQUIPMENT

SECTION D

| | |
|---------------------|-----|
| General Description | D-1 |
| 32 V.D.C. System | D-1 |

| | |
|-------------------------------|-----|
| 120/240 V.A.C. System | D-1 |
| Electronic Distribution Panel | D-1 |
| Distribution Panels | D-1 |
| Safety Pre-Caution | D-2 |
| Optional A.C. Equipment | D-2 |
| Bonding System | D-2 |

| | |
|------------------------------|-----------|
| <u>32 V.D.C. SYSTEM</u> | SECTION E |
| Ungrounded System | E-1 |
| 32 Volt Batteries | E-1 |
| Starter Relays | E-1 |
| Main Fuses | E-2 |
| Ammeter Shunts & Fuses | E-2 |
| 32 V.D.C. Distribution Panel | E-2 |
| Optional D.C. Equipment | E-3 |
| Operation of 32 V.D.C. Panel | E-4 |

| | |
|---------------------------------------|-----------|
| <u>120/240 V.A.C. SYSTEM</u> | SECTION F |
| Introduction | F-1 |
| Shore Power Lines (Standard) | F-1 |
| Cablemaster Shore Lines | F-2 |
| Caution - 220 V.A.C. HZ Operation | F-2 |
| 120 V.A.C. Shore Power Panel | F-3 |
| 120/240 V.A.C. Shore Power Panel | F-4 |
| 120/240 V.A.C. System - Operation | F-5 |
| 120 V.A.C. Panel (Shore Power Mode) | F-5 |
| 120/240 V.A.C. Panel Shore Power Mode | F-5 |
| Outlet Circuits | F-6 |

| | |
|--|-----------|
| Lighting Circuits | F-6 |
| Cold Cathode Lighting | F-6 |
| <u>GENERATOR</u> | SECTION G |
| 120/240 V.A.C. Generator Panel | G-1 |
| 120/240 V.A.C. Generator Panel Operation | G-2 |
| <u>12 V.D.C. SYSTEM</u> | SECTION H |
| Battery | H-1 |
| Battery Charging | H-1 |
| Battery Switch | H-1 |
| Battery Fuses | H-1 |
| Electronic Distribution Panel | H-1 |
| <u>CONVERTORS (BATTERY CHARGERS)</u> | SECTION I |
| 32 V.D.C. Converters | I-1 |
| 12 V.D.C. Converters | I-1 |
| Converter Operation | I-1 |
| <u>AIR CONDITIONING SYSTEM</u> | SECTION J |
| Power Sources | J-1 |
| Mechanical | J-1 |
| Initial Control Check | J-2 |
| Initial Start-Up | J-2 |
| Temperature Adjustment | J-3 |
| Power Interruption | J-3 |
| How to Stop Unit | J-4 |
| <u>FUEL SYSTEM</u> | SECTION K |
| Fueling Instructions | K-1 |
| Fuel Tanks | K-1 |

| | |
|-----------------------------|-----|
| Fuel Supply & Return System | K-1 |
| Constant Trim | K-2 |

| | |
|------------------------------|-----------|
| <u>FRESH WATER SYSTEM</u> | SECTION L |
| Tank | L-1 |
| Deck Fill | L-1 |
| Tank Gauge | L-1 |
| Water Pressure Pump | L-1 |
| Expansion Tank | L-2 |
| Water Heater | L-2 |
| Heater Controls | L-2 |
| Dockside Water Supply | L-3 |
| Laundry Equipment (Optional) | L-3 |
| Ice Maker | L-3 |
| Winterizing Water System | L-3 |

| | |
|---------------------------------|-----------|
| <u>TOILET SYSTEM (STANDARD)</u> | SECTION M |
| Toilets | M-1 |
| Operation | M-1 |
| Salt Tank | M-2 |
| Location of Components | M-2 |

| | |
|--------------------------------------|-----------|
| <u>VENTILATION SYSTEMS</u> | SECTION N |
| Engine Room Heat Removal System | N-1 |
| Engine Room Bilge Blowers | N-1 |
| Generator Bilge Blowers | N-2 |
| Toilet Blowers | N-2 |
| Galley Range Vent | N-3 |
| Laundry Vent (Optional Washer/Dryer) | N-3 |

BILGE AND MISCELLANEOUS PUMPS

SECTION O

| | |
|----------------------------|-----|
| Electric Bilge Pumps | 0-1 |
| Mechanical Bilge Systems | 0-2 |
| Shower Sump Pump | 0-2 |
| Master Stateroom Bath Sump | 0-2 |
| Deck Wash Down Pump | 0-3 |
| Windshield Wipers | 0-3 |

FIRE EXTINGUISHER SYSTEM

SECTION P

| | |
|---------------------|-----|
| | P-1 |
| Agent | P-2 |
| Detectors | P-2 |
| Cylinders | P-2 |
| Alarm System | P-2 |
| Cylinder Check | P-2 |
| Manual Pull Control | P-3 |

PNEUMATIC SYSTEM

SECTION Q

| | |
|--------------|-----|
| Fuel Gauging | Q-1 |
|--------------|-----|

COMMANDING YOUR BERTRAM

SECTION R

| | |
|---------------------------------|-----|
| Pre-starting Instructions | R-1 |
| Starting Instructions | R-1 |
| Maneuvering | R-2 |
| Stopping Engines | R-2 |
| Cruising Speeds | R-2 |
| Cruising | R-3 |
| Calling at ports away from home | R-4 |
| Leaving your Bertram | R-5 |

MAINTENANCE

SECTION S

| | |
|----------------------|-----|
| Periodic Maintenance | S-1 |
| Daily | S-1 |

100 Hour or 60 Day Service

| | |
|--------------------|-----|
| Exterior | S-2 |
| Interior | S-2 |
| Stateroom & Salon | S-3 |
| Galley | S-3 |
| Engine Compartment | S-3 |
| As Required | S-4 |

STORING YOUR BERTRAM

| | |
|-----------------------|-----|
| Dry Storage | S-5 |
| Wet Storage | S-6 |
| Fitting Out | S-6 |
| Pre-Launch | S-6 |
| After Launch | S-6 |
| Electric System Check | S-7 |
| Engine Check | S-7 |
| Controls Check | S-7 |

MAINTAINING YOUR BERTRAM

| | |
|-----------------------------------|------|
| Care of Fiberglass Construction | S-8 |
| Seasonal Care | S-8 |
| Loss of Gloss | S-8 |
| Stains | S-8 |
| Scratches and Abrasions | S-9 |
| Painting Fiberglass Surfaces | S-10 |
| Care of Awl-Grip Painted Surfaces | S-10 |
| Painting Aluminum Surfaces | S-10 |

ILLUSTRATIONS

| | |
|--------------------------------------|------|
| Steering Installation | B-8 |
| Engine Controls | B-9 |
| Propulsion System | C-6 |
| Exhaust System | C-7 |
| Bonding System | D-3 |
| Fuel System | K-3 |
| Fresh Water System | L-4 |
| Drainage System | L-5 |
| Toilet System - Raritan w/Lectra San | N-4 |
| Horn and Fuel Gauge System | Q-2 |
| Dock Plan | S-12 |

CONTROLS AND INSTRUMENTS

Control Stations

On the Bertram 58' Convertible the primary control station is located on the "flying bridge". Additional stations are available as options.

On-Stop and Starter Switches

Prior to starting, check the engines for servicing of oil and water. After the corresponding engine circuit breaker is turned on, the engines are started by first turning the engine on-stop switch to the "on" position; thereby energizing the electrical system. If your boat has more than one station, all the engine switches must be "on". The pilot light will indicate when circuit is energized. Press engine "start" switch until the engine starts; as soon as the engine starts, release the starter switch. This starter should not be operated for prolonged periods which may result in draining the battery or overheating the starter motor or solenoid.

To stop the diesel engine, the on-stop switch should be pushed and held in the "stop" position until the engine is stopped. This shutdown cuts off the fuel supply to the engine. Diesel installations are also equipped with an "emergency stop" handle for each engine, located near the clutch and throttle controls on the bridge. These handles should be pulled only to stop engines in an emergency situation.

Before attempting to restart the engine, after an emergency shutdown, it is necessary to manually reset the air shut-off valve located at the aft end of the engine on the blower-inlet air silencer case. (See Engine Operating Manual.)

ACCESSORY SWITCHES

Each of these toggle switches operates lights or electrical accessories as marked and get their power from the engine starting batteries through the 32 V.D.C. Panel. Excessive use when the engine is not charging the battery could make engine starting difficult.

HORN SWITCH

This switch activates a solenoid which controls the air supply to the horn from the air tank. The entire unit, with the exception of the trumpets, is located in the engine room, on the starboard side.

BATTERY PARALLELING SWITCH

The battery paralleling switch may be held in the starboard or port position when operating the starter switch. The paralleling switch will enable you to use either battery bank to assist the other when starting.

THE IMPORTANCE OF INSTRUMENTS

To avoid mechanical damage, become accustomed to checking your instruments frequently when running and particularly when first starting the engine.

GAUGES

Mechanical gauges are: engine oil pressure, gear oil pressure and engine temperature.

Electrical gauges are: tachometer, ammeter, and fuel.

For the GM 12V71T engines, the normal gauge readings are as follows:

Oil Pressure: 8 to 10 PSI @ 600 R.P.M.

50 to 70 PSI @2300 R.P.M.

Drive Oil Pressure: (MG-514 Gear)

60 to 65 PSI in Neutral @1800 R.P.M.

185 to 215 PSI Engaged @1800 R.P.M.

Cooling Water Temperature: 160 to 185 F.

Ammeter: 0 to "Charging " +

AMMETER

This is an indicator which measures the rate of electrical current charging or discharging the storage battery. The ability of the alternator to maintain a charge depends on the ratio of current generated and the rate of consumption by the electrical equipment. A low charging rate indicates the batteries are at full charge and the accessory demand is low.

FUEL GAUGES

The fuel gauges are located at the primary control station on the fly-bridge. There are four tanks, each has a capacity of 325 gallons (U.S.) for the standard fuel capacity of 1300 gallons (U.S.). The four tanks have a capacity of 500 gallons (U.S.) when 2000 gallons (U.S.) is ordered.

The port gauge is for the aft tanks and the starboard gauge is for the forward tanks. The system is Hydrostatic Levelometer and gives a constant reading as long as there is an air supply from the air tank.

LUBE OIL PRESSURE GAUGE

Almost all serious engine trouble will be reflected by the oil pressure gauge. Therefore, if a radical change in pressure should occur, turn the engine off immediately and check the engine for leaks, proper oil level or other apparent malfunctions. During operation, there may be some slight fluctuation in gauge reading. This is normally due to the nature of the lubricating oil and the temperature variation. Consult your engine manual for operating pressure.

TEMPERATURE GAUGE

The temperature gauge records the temperature of the water circulating through the engine. All engines are equipped with a thermostat that controls the water flow, thus determining the temperature. The temperature and oil pressure gauge should be observed simultaneously as most malfunctions will be reflected in both gauges. Consult engine manual for further information.

NOTE: If water temperature rises, oil pressure will drop.

TACHOMETER

This instrument registers the revolutions per minute of the engine. There is no direct correlation of R.P.M. to speed of the boat due to the reduction gear and propeller slippage.

DRIVE OIL PRESSURE GAUGE (MG-514 Gear)

This gauge records only gear oil pressure applicable to the transmission. Consult your transmission manual for operating pressure. Dual control boats will have gauges at the flybridge control only.

HOUR METER

This instrument records the number of hours that the engine has been operating, regardless of engine speed (R.P.M.). Meters are energized by the On-Stop circuits and are located in the engine room.

WATER GAUGE

The water level gauge is located in the galley. It is electrically operated by a sender in the tank. The fresh water pump circuit breaker must be turned "on" before gauge will operate. A single tank is located in the lazarette with a capacity of 300 gallons (U.S.)

SAFETY ALARM SYSTEM

This system gets its power from Breaker #32 of the 32 V.D.C. panel. This breaker should be "on" at all times.

The engine section of the system has red warning lights to indicate excessive engine temperature or insufficient oil pressure. Test switches are provided to check operation of lights and bells. Test should be made prior to starting engines. These lights are located on the main panel, on the flybridge.

The bilge alarm has 3 float switches located above any normal bilge water, but low enough to signal any flooding condition.

These float switches should be checked periodically to be sure they are free of debris and that they will sound the alarm when float is raised.

The fire alarm has three heat activating detectors located in the main engine room and generator room, to signal in case of excessive heat that would normally be generated by a fire.

CONTROLS

The Flybridge Control

The flybridge control panel contains all controls, gauges, and switches necessary for the control of the boat. Included on the control panel are engine throttle control, marine gear control, blower switches, navigation light switches, fuel gauges, compass light, horn switch and bilge pump switches.

Clutch and Reverse Control

Clutch controls are installed on the control panel within easy reach of the helmsman's left hand. They use Controlex push-pull cables directly connected to the marine gear.

Throttle-Governor Control

These controls are at the helmsman's right hand. Moving the control lever transmits motion from this control head to the control unit in the engine room by means of Controlex push-pull cables.

Additional controls may be added without appreciable increase in control effort.

Steering Control (Hynautic-Hydraulic)

The steering system consists of hydraulic pump and pilot check valve, to which the steering wheel is attached. When the wheel is turned, hydraulic fluid is pumped to the steering cylinder attached to the rudder arm. There is a hydraulic fluid reservoir installed in the system. The reservoir contains 2 quarts of fluid under about 30 PSI air pressure. This prevents outside air from entering the system. The reservoir has a sight glass indicating the fluid

level. Normal level is about 2" from the top. The air pressure can be recharged by using an ordinary tire pump. The tire valve is on top of the reservoir, to which the pump can be attached. The reservoir is located in the lazarette on the starboard side, against the transom.

The steering cylinder is a double acting type with direct mechanical linkage to the tiller arm. The system gives instant rudder response and will provide a hydraulic lock against any rudder forces.

Additional steering controls or automatic pilot may be added without adding additional steering effort.

The rudder indicator gets it's power from the port engine ignition switch. The indicator should be adjusted to read full scale, each side of of center. The controls are located inside the flybridge console.

| REVISIONS | | |
|-----------|-------------|---------|
| NO. | DESCRIPTION | BY DATE |
| | | |

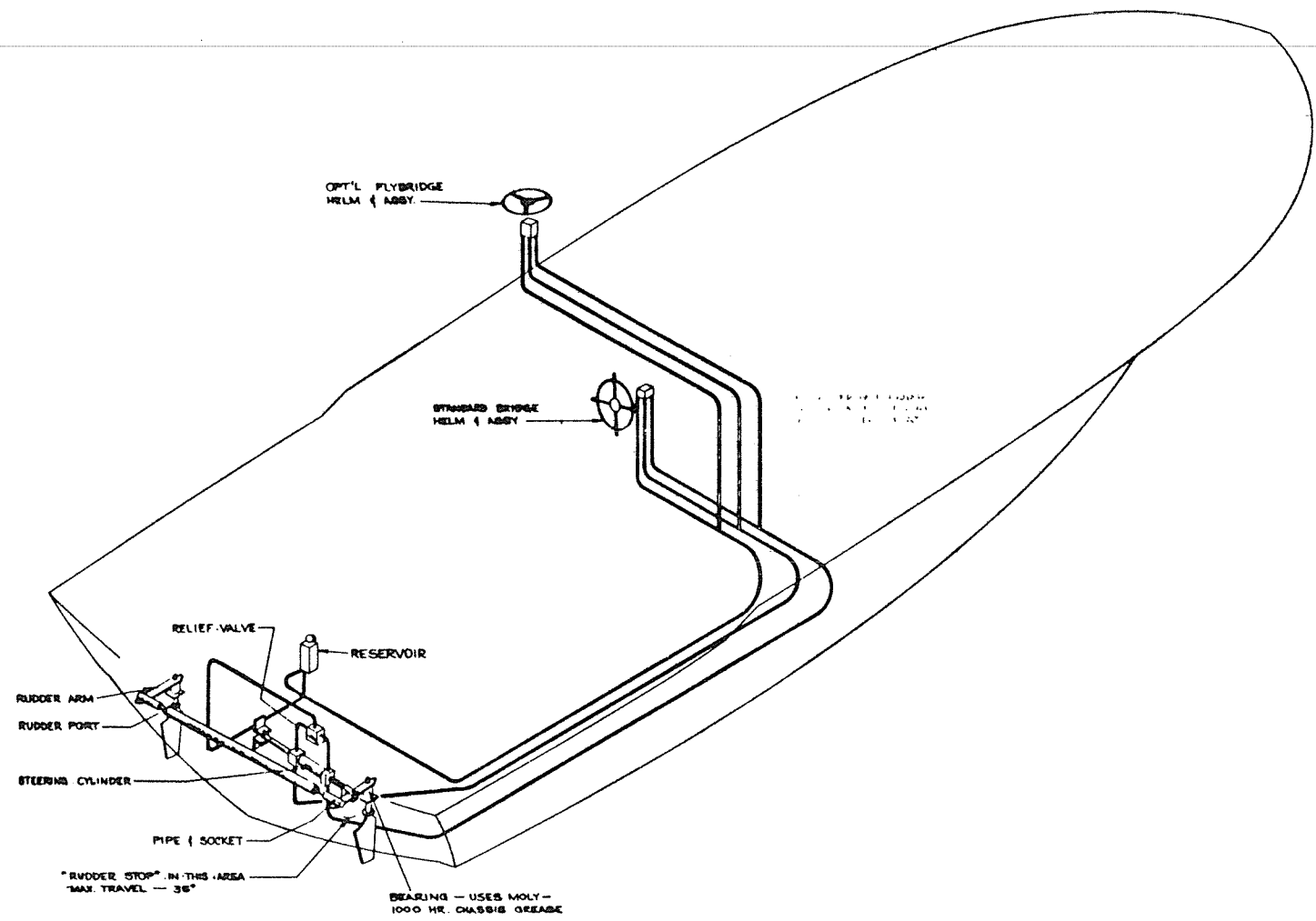

| | | | |
|--|----------|-----------|------|
| BERTRAM YACHT MIAMI, FLORIDA, U.S.A. A SUBSIDIARY OF WHITTAKER CORPORATION | | | |
| WOL 587 & 585 | | | |
| STEERING SYSTEM | | | |
| SCALE N.T.S. | PLAN NO. | REV. | |
| 0-16 | 4235 | 1 | 4235 |
| 01-11-74 | 10/27/74 | PWA 50 21 | |

| REVISIONS | | | |
|-----------|-------------|----|------|
| NO. | DESCRIPTION | BY | DATE |
| | | | |
| | | | |

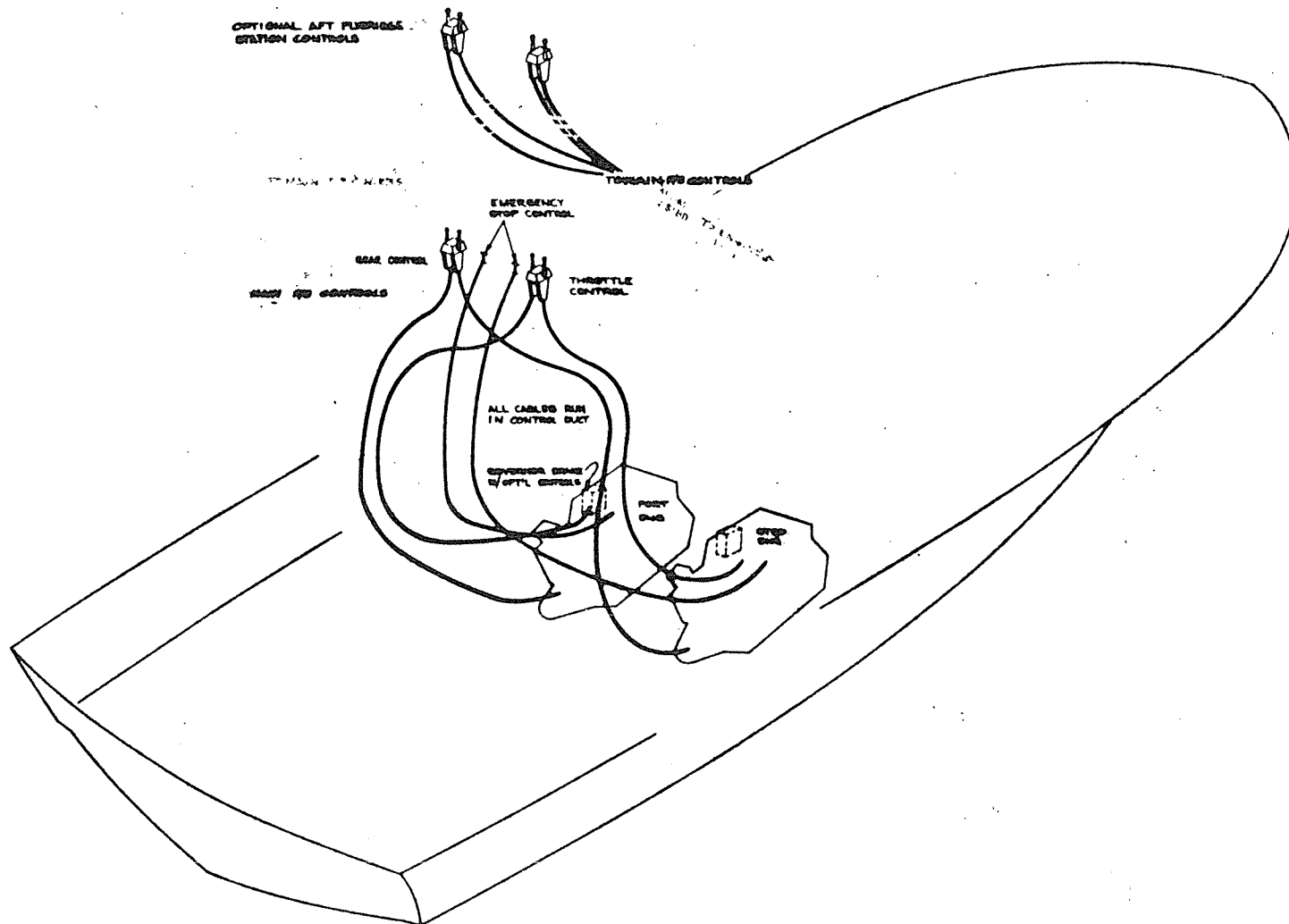

| | | | |
|-----------------------------------|----------|----------|------|
| BERTRAM YACHT | | | |
| MIAMI, FLORIDA, U.S.A. | | | |
| A DIVISION OF BERTRAM CORPORATION | | | |
| MODEL 58 J | | | |
| TITLE | | | |
| ENGINE CONTROLS | | | |
| DATE | BY | PLAN NO. | REV. |
| MAY 1964 | W. J. W. | 6083 | |
| NO. 58 JT | | | |

REVISIONS

| LET. | DESCRIPTION | BY | DATE | APP. |
|------|-------------|----|------|------|
|------|-------------|----|------|------|

TILLER ARM BYD 06C3753, 2 REQD
 BALL SPHERE BYD 06.099, 2 REQD
 SOCKET ASSY BYD 06.093, 2 REQD
 ROD, COUN. BYD 06B4470-1, 1 REQD

STOP, RUDDER 2 REQD
 BYD 06.338
 HHMB 3/8-16 X 3/4" 8 REQD
 BYD 50.125
 WASHER, FLAT 3/8" 8 REQD
 BYD 50.036
 NUT 3/8-16 FLEXLOC 8 REQD
 BYD 50.485

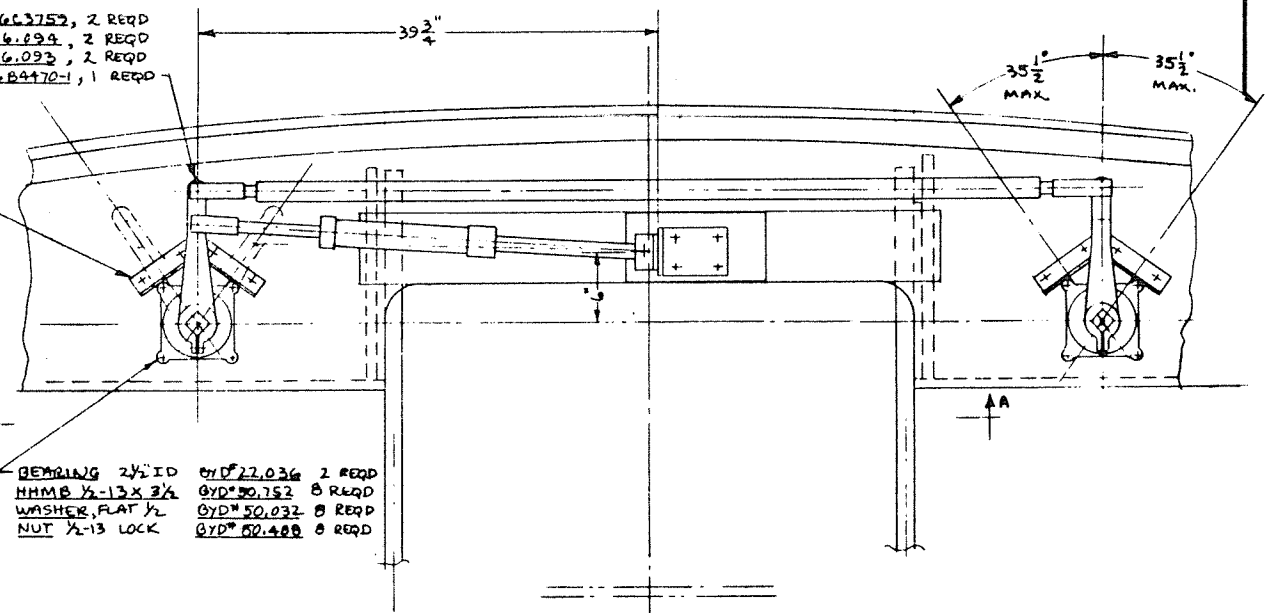

BEARING 2 1/2 ID BYD 22.036 2 REQD
 HHMB 1/2-13 X 3/4" BYD 50.153 8 REQD
 WASHER, FLAT 1/2" BYD 50.032 8 REQD
 NUT 1/2-13 LOCK BYD 50.488 8 REQD

RUDDER BYD 06E3752 2 REQD
 NUT, 2 1/4-4 BYD 06C3790-1 4 REQD

PORT RUDDER BYD 06C3753, 2 REQD
 GLAND BYD 06C3755 2 REQD
 PACKING BYD 25.007 6 FT
 BOLT 3/8-16 BYD 08.125 4 REQD
 WASHER 3/8" BYD 50.355 12 REQD
 NUT 3/8-16 BYD 51.237 4 REQD
 BOLT 3/8-16 X 4 BYD 50.165 8 REQD
 NUT 3/8-16 BYD 50.475 16 REQD

BRACKET (PART OF PACKAGED KIT)
 HHMB 1/2-13 X 6" BYD 50.711, 4 REQD
 WASHER, FLAT 1/2" BYD 50.032, 4 REQD
 NUT 1/2-13 LOCK BYD 50.488, 4 REQD

MANG BLOCK 2 5/8" X 6" X 12"

1" X 6" X 52" P/W STIFFNER
 SECURE TO RUDDER SHELF W/
 RESORSEVAL GLUE & WOOD SCREWS.

VIEW A-A
 VIEW LOOKING AFT

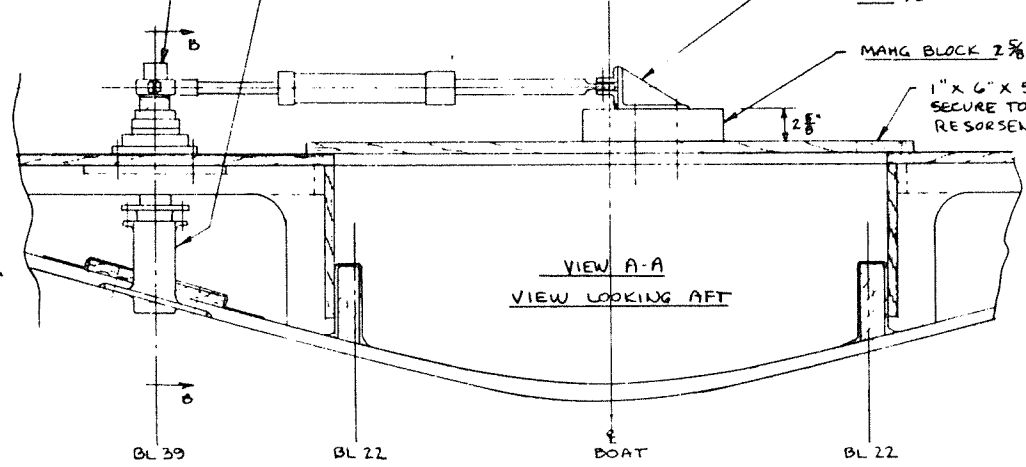
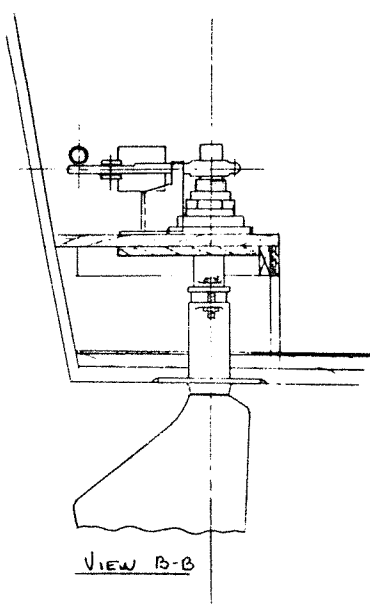

REF. PLAN # 33E3772 FOR INSTL OF SHAFT,
 SHAFT LOG, MAIN & INTERMEDIATE STRUTS.

| | | | |
|---|----------------------------------|---------|-----|
| BERTRAM YACHT MIAMI, FLORIDA, U.S.A. A SUBSIDIARY OF WHITTAKER CORPORATION | | | |
| MODEL | 585 | | |
| TITLE | STEERING INSTALLATION - AFT - | | |
| SCALE | 1/2" = 1'-0" | PLAN NO | REV |
| BY | APPROVED | DATE | |
| DATE | 3-2-76 | | |
| 33C 5145 | | | |
| FILE INSTL. | | | |

33C5145

PROPULSION EQUIPMENT

Engines

All necessary data and information about the engines are contained in the Engine Operator's Manual, so they are not repeated here. Just a reminder, the life and performance of the engines are dependent on the way they are cared for, so follow the manufacturers instructions and watch the instruments carefully to obtain many hours of pleasurable boating.

Marine Gears (Twin Disc MG-514)

The gear unit, affixed to the after end of your engine, is a hydraulically operated forward and reverse transmission and reduction gear. Information and maintenance procedures can be found in the Transmission Manual.

Propeller Shafts

Information as to size, length, and material of shaft will be found on the Technical Data page at the front of this book.

Shaft Alignment

At the factory, your propeller shafts were aligned properly, but it should be checked periodically to insure continued proper alignment and performance. To check alignment, first remove the bolts in the coupling flanges at the end of the marine gear. Using a .010 feeler gauge, press the flanges together by hand. The feeler gauge should be inserted at 90° intervals to assure equal clearance at all faces. If the alignment is correct, the .010 or .013 feeler gauge will be tightly gripped at all

points around the edges of the coupling. In other words, the faces when touching should be no more than .003 inch apart at any other point.

Shaft Log and Stuffing Box

The shaft log is the tunnel that the propeller shaft turns in and is of fiberglass construction. On the inside end of the shaft log, there is a stuffing box attached by a flexible rubber hose and held in place by hose clamps. This flexible hose allows for a misalignment of .010 inch without undue wear of the packing gland itself. The stuffing box is packed with braided flax packing and is kept fairly tight to keep water from leaking past the packing. It is normal and necessary to have a slight drip of water from the stuffing box as this serves as a lubricant, but if the leaking is excessive, the packing gland should be tightened. Be careful not to tighten too much as this will glaze the packing, and score the shaft. If the packing is too tight, the gland will get too hot to hold with your hand. Normally, when running at full speed, the gland will be warm.

If necessary to repack the gland, remove the boat from the water, back off both lock nuts and slide the packing gland forward on the shaft. Be sure that the old packing is removed and install five $\frac{1}{4}$ " x $\frac{1}{4}$ " rings of new packing. Slide packing gland aft and tighten to a point where there is a slight drip of water. Tighten so shaft will not move. This will seat packing. Back off until shaft is free. Run shaft for awhile and reset. Always use Tallow flax packing. Do not spiral around the shaft, each ring must be separate.

CAUTION: Always tighten packing gland evenly. One turn on each nut at a time will avoid any problems.

Propellers

Information on propellers will be found on the Technical Data page of this book. The propellers recommended are those with which your boat was tested. If weight has been added or the operating characteristics have been changed due to addition of special equipment, it may be necessary to change the pitch to suit existing conditions.

Installation of Propellers

Propeller bore and the end taper of the shaft must be clean and free of any obstructions. In order that the propeller seats securely on the shaft, the keyways must be free from burrs and corrosion. Insert the key with its round end forward on the shaft, aligning the keyway. The key should fit snugly on each side of the keyway, but clearance at the top is essential so as not to pull the propeller off center and thereby cause vibration. After proper fitting, assemble the propeller nut, locking nut and cotter pin on the shaft. The key must go on the shaft first.

Exhaust System

The aluminum main engine exhaust mufflers are located in the engine room aft of the main engines.

Boat Speed

Boat speed is dependent on many variable factors, so no catalogue or advertised speed can be guaranteed. A short discussion of some of the more important factors affecting boat speeds are presented below.

Engine Efficiency

With normal care and maintenance, the engines will maintain peak efficiency; however, if they are neglected, the power will fall off and expensive repairs could become necessary. Take care of the engines!

Atmospheric Conditions

Engines will develop more power when the ambient air and water temperatures are cool, in fact the power variations due to temperature can be as much as ten percent. For this reason greater speeds are generally obtained in the spring and fall, rather than in the summer.

Personal Equipment and Accessories

All personal equipment and accessories added to the boat will tend to decrease the speed, just as adding passengers will. Often the effect of this added weight is not taken into consideration on the performance of the boat.

Testing

All new models when first launched undergo an extensive testing program to test systems reliability, boat performance and optimum propeller size. All testing is carried out with the boat in two conditions of displacement and trim.

Test Condition I (Normal)

Two-thirds fuel and water, all optional equipment, provision for a crew of six and approximately 2000 pounds extra.

Test Condition II (Heavy)

Same as Condition I, but with full fuel and water tanks. The propeller selection is usually determined with the boat in normal condition, providing the selection will allow for the additional weight as found in condition heavy.

Marine Growth

In order to obtain maximum speed, the bottom of the boat must be kept free of marine growth, including moss. Any growth on the boat's bottom will increase the resistance of the boat as it moves through the water, thus decreasing speed by as much as 20%.

Water in the Bilge

Water weighs approximately 8.5 pounds per gallon, so even one barrel of water in the bilge adds over 400 pounds to your boat. The bilges must be kept dry in order to keep excess weight down. As mentioned before, added weight will reduce boat speed.

Damaged Underwater Equipment

Loss of speed and excessive vibration can result from damaged propellers, shafts, or struts. Any damage to the underwater gear should be repaired as soon as possible.

| REVISIONS | | | |
|-----------|-----------------|----|------|
| NO. | DESCRIPTION | BY | DATE |
| 1 | REVISED DRAWING | | |
| 2 | REVISED DRAWING | | |
| 3 | REVISED DRAWING | | |
| 4 | REVISED DRAWING | | |
| 5 | REVISED DRAWING | | |

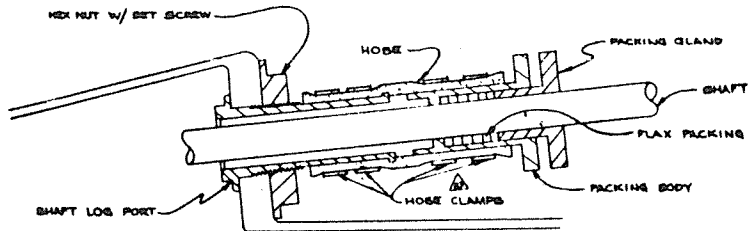

SHAFT LOG ASSEMBLY

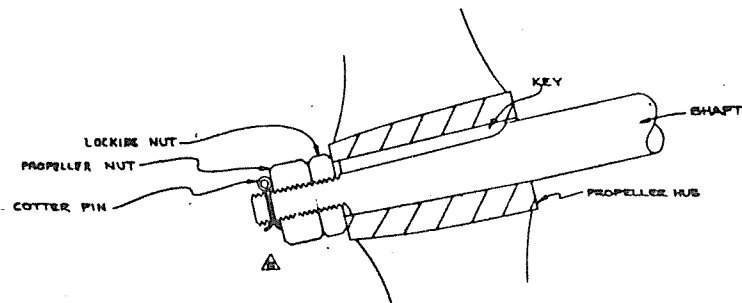
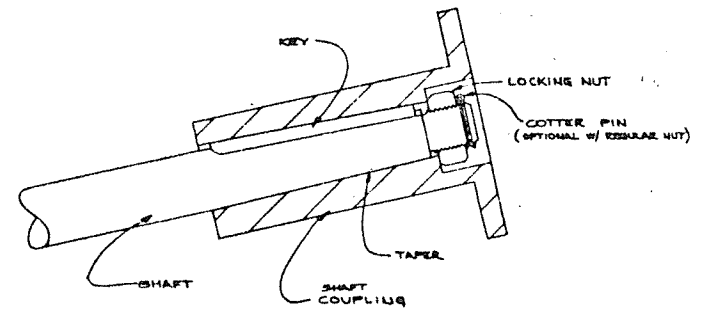
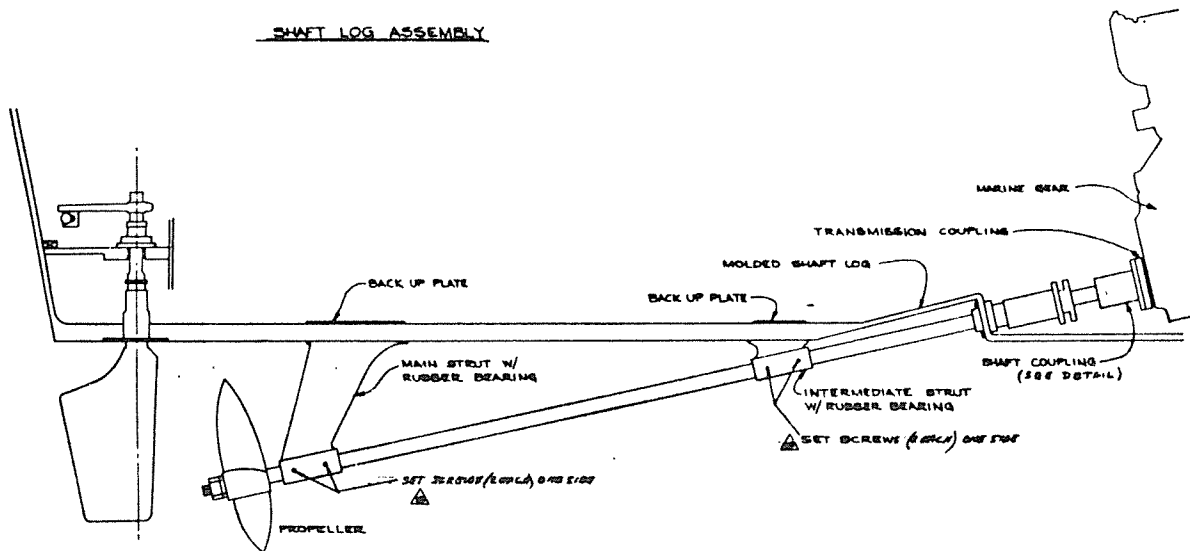

| | | | |
|-----------------------------------|-----|----------|---|
| BERTRAM YACHT | | | |
| MIAMI, FLORIDA, U.S.A. | | | |
| A DIVISION OF BERTRAM CORPORATION | | | |
| MODEL 58 | | | |
| PROPULSION SYSTEM | | | |
| DATE | BY | PLAN NO. | |
| 11-78 | RAY | 04271 | A |
| 1/4" = 1'-0" | | | |

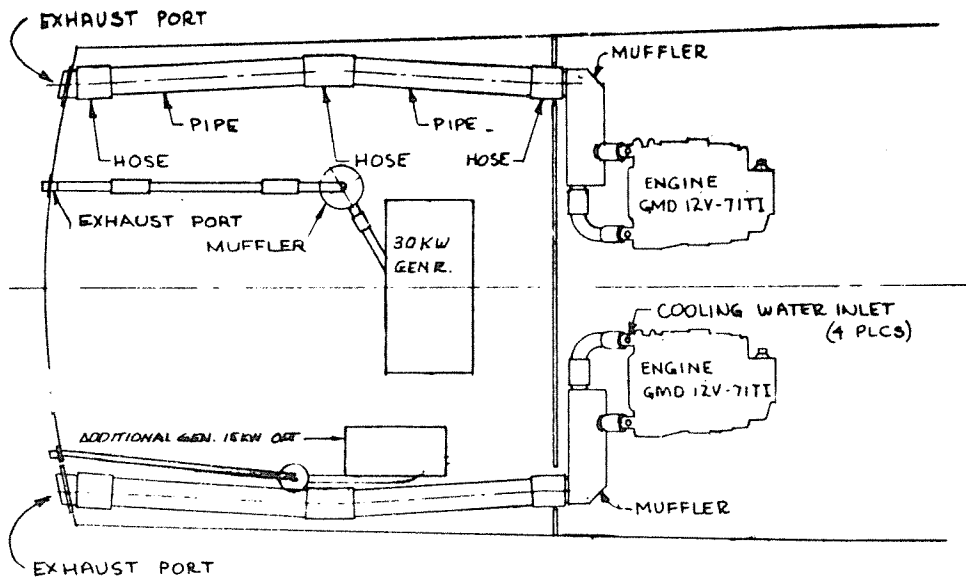

| LET. | DESCRIPTION | BY | DATE | APPV. |
|---|--------------------------|----------|------|-------|
| REVISIONS | | | | |
| BERTRAM YACHT MIAMI, FLORIDA, U.S.A. A SUBSIDIARY OF WHITTAKER CORPORATION | | | | |
| MODEL 585 | | | | |
| TITLE EXHAUST SYSTEM | | | | |
| SCALE NONE | | PLAN NO. | | REV. |
| BY EDV | APPVD <i>[Signature]</i> | B | 6084 | |
| DATE 3-26-79 | DATE 1/27/79 | | | |
| FILE 585 | | | | |

801-20-101-101

ELECTRICAL

General Description

Your Bertram yacht is equipped with three basic electrical systems. They are unique in many ways.

32 V.D.C. System

This is powered by the engine starting batteries and engine alternators. It is an ungrounded system and both positive and negative conductors are protected by circuit breakers or fuses.

120/240 V.A.C. System

This system is powered by two shore lines, one 120 V.A.C., the other 120/240 V.A.C. and by a ship generator. Converters are provided to keep engine and generator batteries charged when the engines are not running.

Electronic Distribution Panel

The generator starting battery is also used to supply power to the Electronic Distribution Panel. This system is 12 V.D.C., negative grounded which is standard. An option is available for 32 V.D.C. ungrounded.

Distribution Panels

Each system has its own distribution panel. Each circuit breaker is identified by name and number. These numbers are used to trace all circuits shown in the Wiring Diagram Section of this manual. Complete details will be found in the Electrical Sections that follow.

Safety Precaution

If for any reason it should be necessary to open the 120/240 V.A.C. Panel, the shore lines should be disconnected at the dock. The generator should be stopped and the Generator Main Breaker (#43 for single generator) turned "off".

Breaker #111 will also have to be turned off when optional dual generator is installed.

Optional A.C. Equipment

Optional equipment that is not installed by the factory may be added by the dealer or the owner.

Blank covers are used to conceal the holes and engraved names for unused optional circuits.

Bonding System

Your Bertram is fitted with a bonding system to minimize electrolysis. This system consists of copper strips running fore and aft through the bilge area. All underwater fittings and hardware are connected with wire jumpers to these strips.

All A.C. equipment and devices (other than lights) are connected with a green wire to the bonding system. This is done to reduce danger of an electrical shock from high voltage equipment.

| REVISIONS | | | |
|-----------|-------------|----|------|
| NO. | DESCRIPTION | BY | DATE |
| | | | |
| | | | |

50/50 MCM WHITE WIRE (NEUTRAL) MUST BE
ISOLATED FROM BONDING SYSTEM

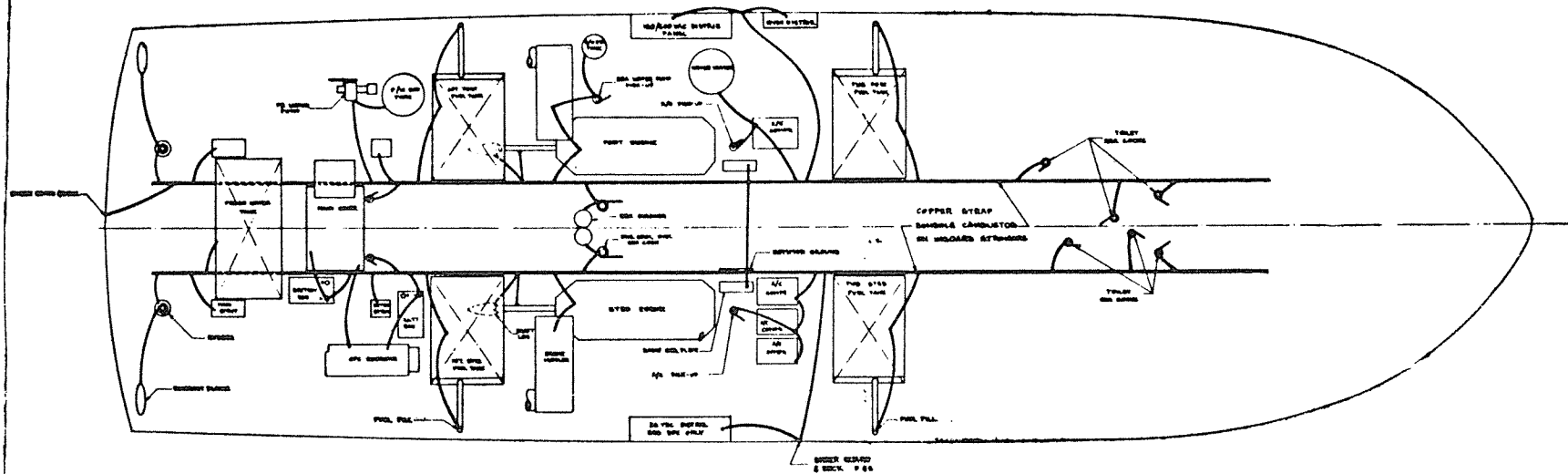

1. 20 VOLT BATTERIES ARE NOT GROUNDING.
2. 12 VOLT SYSTEM IS NEGATIVE GROUNDING.

| | | | |
|---|---------------------|------|--------|
| BERTRAM YACHT MIAMI, FLORIDA, USA <small>A Subsidiary of WESTYAC CORPORATION</small> | | | |
| MODEL | 585 | | |
| TITLE | BONDING & GROUNDING | | |
| SCALE | NONE | | |
| BY | DATE | BY | DATE |
| | 5-7-77 | | 5-1-77 |
| | | 5289 | |
| | | 50P | |

32 V.D.C. SYSTEM

UNGROUNDING SYSTEM

This boat has an ungrounded system, neither the negative or positive sides of batteries are grounded. It is called an "isolated system" or "floating system" and provides maximum protection from electrolysis. It is most important that this isolated condition be maintained and that your boat yard, marina and service people are so advised.

32 VOLT BATTERIES

Each engine has a bank of four 8-volt batteries. The starboard bank is for the starboard engine, and the port bank is for the port engine. Each bank has a capacity of 175 amp/hours (20 hour rate). These can be put in parallel by activating the Battery Paralleling switch in the console when starting the engines. This closes a relay (contactor) that is located between the starting relays near the batteries.

Water in all batteries should be kept $\frac{1}{4}$ " above the top of the plates to insure maximum service.

STARTER RELAYS

Between the positive battery cable and the engine starter is a relay (contactor) that is actuated by the 'start' switch on the console. Thus, the starter cables in the engine room are "hot" only while the engines are being cranked.

Main Fuses

In a metal box on the forward bulkhead, starboard side of the generator room are four 60 amp cartridge fuses that protect the main feed lines to the 32 V.D.C. electrical panel. These fuses supply all 32 V.D.C. power to the panel and other equipment.

Ammeter Shunts and Fuses

On the load side of each positive main fuse is an ammeter shunt. On each side of each shunt is a 10 amp in-line fuse that protects the leads to the ammeter. Never allow anyone to connect any accessory or light to one of the ammeters.

32 V.D.C. Distribution Panel

On the starboard side of the deckhouse is the 32 V.D.C. distribution panel. Power from the batteries comes through the main fuses and shunts (in the engine room) to the Port and Starboard Battery Main circuit breakers, #7 & 8, on each side of the Battery Condition meter.

These breakers (50 amp) not only protect the battery feed from overload but replace the "master switches" usually located in the engine room. They should be turned "off" when the boat is left unattended.

At the top of the panel are the Bilge Pump and Safety Alarm breakers #31, 33, 32, and 34. These are normally left "on" at all times and since they are connected to the battery side of the main breakers they are still "hot" even when main breakers are "off".

The Battery Condition meter reads the voltage of either engine battery by using the selector switch. The meter consumes so little current that it can be left permanently connected. It can thus monitor the converter,

even though the main breakers may be "off.

The remaining circuit breakers, #41 to 76, are controlled by the main breakers.

Notice that all the circuits on the Port Battery are red and have odd numbers. Starboard Battery circuits are green and even numbered. These numbers correspond to the numbers in wiring diagrams and wire markings.

At the bottom of the 32 V.D.C. Panel are the remote controls for the converters. See Converter Section for details.

OPTIONAL D.C. EQUIPMENT (not installed at the factory)

Optional equipment that is not installed by the factory may be added by the dealer or by the owner.

Blank covers are used to conceal the holes and engraved names for unused optional circuits. Check page 32 DC #2 in the wiring diagrams.

All 32 V.D.C. circuit breakers on this boat are of the two pole, common trip type that disconnect both current carrying conductors usually red and brown wires. The brown wire (except on certain switch legs) is the negative wire and like the positive red wire is isolated from the boat ground. It is mandatory that any breakers added to the panel be installed in the same manner and be of the proper size and type.

NOTE: If equipment is added by the factory and not covered by the manual, please check additional equipment literature that comes with your boat.

OPERATION OF 32 V.D.C. PANEL

After having read the complete description of the 32 V.D.C. System and compared it with all the actual parts, you will find the following step-by-step procedure helpful in the actual operation.

1. Be sure the four main fuses are in place (in the generator room).
2. Turn "On" Main Port and Starboard Breakers.
3. Turn "On" breakers for bilge pumps (#31,33,34) and Safety Alarm 32.

These are always left "On" while the boat is in service.

4. Turn "On" the breaker that controls the unit or circuit you're to use, each is clearly labeled. You may find it helpful when at the dock with guests aboard, to be sure that all breakers controlling equipment used only when the boat is underway are turned off.

Example:

5. To run engines. Turn "On" mains 7 & 8. Turn "On" port and starboard engines 41 & 42. Go to each station and turn the ON-STOP switch to "on" position. Signal next to each switch will light when circuit is energized. (Press start switch until engine cranks.)
6. Remote converter controls at bottom of panel.
 - A. Turn switch to "On" position.
 - B. Turn other switch to "Auto" position.
 - C. It is best to leave both switches in these positions at all times.
(See converter Operation for exceptions and complete details)
 - D. The 120 V.A.C. power must be available and the converter circuit breaker #101 and 104.
 - E. The Full Charge indicator will light when batteries are fully charged. The converter will then automatically shut itself off completely.

120/240 VOLT A.C. SYSTEM

Introduction

The 120/240 V.A.C. Panel is simple and logical once you have studied the description that follows.

Work with this panel for awhile and you will be able to operate and make the desired selections with speed and precision.

If you are hesitant to start with a "hot" panel, we suggest you make a few dry runs with all power disconnected.

We also suggest that you study the 120/240 Distribution System -- Block Diagram in the Wiring Diagram Section (page 585 AC-1). This will help you visualize the "flow" of AC power to all parts of the panel.

Shore Power Lines (Standard Equipment)

Your Bertram has two shore connections on the port side and two on the starboard, located in the cockpit pilaster. Each has 50 amp capacity; one is for 120 Volt, the other for 120/240 Volt.

The two 50' cord sets are made to fit 50 amp outlets and inlets. The 120 Volt set has a 3 wire cable and the 120/240 Volt set has a 4 wire cable. See page 585- AC#4 in Wiring Diagrams.

Bertram shore lines are wired in accordance with current industry standards, however, you may find some dock outlets improperly wired.

Always attach the cord set to the boat first, twist-locking it carefully, then attached other end to the shore outlet. This will prevent the accidental dropping of a "hot" cord into the water. For the same reason when disconnecting the shore line, remove the end at the dock outlet first.

CABLEMASTER SHORE LINES (OPTIONAL EQUIPMENT)

If your boat is so equipped, you will need to have the 120 V.A.C. circuit breaker at the bottom of the 120 volt panel turned on before the cablemaster shore lines can be used. A switch beside each hullside inlet is used to expel the cable. When fully extended, the drive unit will shut itself off. To retract cable, turn switch in opposite direction. Drive unit will shut off automatically when cable end is fully housed. Before getting underway be sure to close covers by lifting up on the hinges joint.

CAUTION: 220 V.A.C. - 50HZ operation

Unless your boat has been especially equipped it cannot operate on 220 V.A.C. shore power that is of the "two wire" type which is common in many other countries.

Our standard electrical system requires "three wire" shore power. That is, there should be a neutral wire (ground potential) and two "hot" wires. In addition, there should be a 4th wire that is the safety ground (green wire).

Between the neutral wire and either "hot" wire is a potential of 110 to 125 volts. Between the two "hot" wires is a potential of 220 to 250 volts.

Our special (optional) system for 220 V.A.C. 50Hz operation employs a step-down transformer for the 120 V.A.C. shore supply and an isolation transformer for the 220 V.A.C. shore supply that has a center tap on the secondary to provide a neutral wire for 110/220 voltages within the boat's system.

Most of the boat's standard electrical equipment is compatible with either 50 or 60 Hz power. However, some changes must be made unless your boat was especially built to operate on 50Hz power.

120 VOLT A.C. SHORE POWER PANEL

This section of the alternating current distribution panel (left side) is to supply power only to branch circuit breakers #101 to #112 (and 113 to 116 if added).

Power can come from either the 120 V.A.C. shore line or from the generator.

The 90-130 voltmeter and 0-60 ammeter on this panel will register only when the 120 V.A.C. shore line is in use.

There are two polarity lights for the 120 V.A.C shore line. If the safe (amber) light is lit, the polarity is correct and you may safely turn on the Shore Main Breaker (100).

If the "Rev.Pol." (red) light should light, the polarity is reversed and corrections must be made on the dock before turning on the circuit breaker. If the pair of lights (red and amber) should light, this indicates an extremely dangerous situation: that the "Hot" shore wire (usually black and red) has been connected to the ground connection. If this should happen, remove the cord from the shore outlet immediately and have the outlet corrected.

On this 120 V.A.C. panel we provide power to those equipment items that are essential to maintain the boat for long periods when no one is living aboard or when 220 V.A.C. shore power is not available.

It is possible in some cases to plug into a 30 ampere shore outlet, by using a proper adapter (pigtail), but it will be necessary to turn off those branch breaker that might cause an overload condition.

An overload that caused voltage to drop below 110 volts can cause overheating and damage to electric motors.

120/240 VOLT A.C. SHORE POWER PANEL

This section of the alternating current distribution panel (right side) is to supply 120 volt power to branch breakers #121 to 126 (and 127,128 if added) and 240 volt power to branch breakers #201 to 208.

Power can come from either the 120/240 V.A.C. shore line or from the generator.

The 180 to 260 voltmeter and the two 0-60 ammeters on this panel will register only when the 120/240 V.A.C. shore line is in use.

Since the shore power for this panel is only 50 amperes, it is quite easy to overload the Main Breaker (#200) causing it to trip. Keep in mind that the total running load for the air conditioning system alone is about 31 amps. If it is necessary to use the other high amperage equipment, it is best to use the generator for power.

120/240 V.A.C. SYSTEM - OPERATION

Read the preceding description of the 120/240 V.A.C. System and study the actual parts and arrangement on the boat. The following step-by-step procedure will place your panel in operation.

120 V.A.C. Panel (Shore Power Mode)

1. Shore-Ship switch should be "off".
2. Connect 120 V.A.C. shore line to either port or starboard inlet.
3. Connect shore line to dock outlet.
4. Turn port-starboard switch to correct position.
5. Check polarity lights to see that only the "safe" (amber) light is lit.
6. Voltmeter should show "no-load" voltage of shore power.
7. Turn Main Breaker (# 100) to "on" position.
8. Turn Shore-Ship switch to "shore".
9. The breakers (101- 112) are now energized and may be turned "on" as required. Normally, all of the breakers are left "on" most of the time.

120/240 V.A.C. Panel (Shore Power Mode)

1. Shore-Ship switch should be "off".
2. Connect 120/240 V.A.C. shore line to either port or starboard inlet.
3. Connect shore line to dock outlet.
4. Turn port-starboard switch to correct position.
5. Voltmeter should show "on-load" voltage of shore power.
6. Turn Main Breaker (# 200) to "on" position.

7. Turn Shore-Ship switch to "shore".
8. The breakers (#121-129) are now energized and may be turned on as required. Normally, all of the breakers are left "on" most of the time.

Outlet Circuits

There are special service outlet circuits with their own circuit breakers, each breaker is marked.

The breakers #109 and 112 are for Port and Starboard outlets, respectively. There are a number of outlets on each circuit and their location may vary from boat-to-boat. We suggest that you make a list of the outlets on each of these circuits and add it to this manual. A test lamp and plug will make the job easy, if you turn on only one circuit at a time.

Lighting Circuits

There are two circuits #150 and 108 that feed all the A.C. lighting; they are roughly divided as to Port or Starboard. However, like the outlet circuits, they can vary from boat to boat, so another list for each breaker may be helpful.

Cold Cathode Lighting

There are two such systems in your boat. One in the deckhouse, the other in the galley. The light tubing is behind the curtain valances and since they operate on 9000 volts, care must be taken to avoid touching them unless the system is turned off.

There is a high voltage transformer and low-current fuse for each system. In the deckhouse they are located in the locker port side aft. In the galley they are located under the dinette in the locker starboard.forward corner.

NOTE: This type system is similar to neon lighting, except argon gas is used. A neon sign maker can repair or service it, if necessary.

120/240 V.A.C. GENERATOR PANEL

The center section of the A.C. distribution panel is to supply ship power to all the 120 and 240 volt branch circuits on the entire panel.

The generator can be started and stopped with the remote controls at top of the panel. The blower should be run for at least two minutes before and during generator starting.

If the generator engine does not run smoothly (RPM varies) when started, momentarily move switch to "stop" position and then return to "on". This should remedy the situation.

The 180 to 260 voltmeter will indicate when the generator is running. The two 0 to 150 ammeters will indicate the amount of current used in each "hot" line.

Notice that all odd numbered 120 V.A.C. branch breakers receive generator power through the left hand 0-150 ammeter. All even numbers get power through the right hand 0-150 ammeter. This is why one ammeter may register different than the other. All 240 V.A.C. branch breaker draw equal current through both 0-150 ammeters.

The branch circuits "Anchor Windlass" (#131) and optional "Fresh Water Maker" (#132) can be powered only by the generator. There should never be any need to use shore power for such equipment.

Since the standard 30 KW generator has ample capacity it is not necessary to use shore power when the generator is running.

120/240 V.A.C. GENERATOR PANEL
OPERATION

For more details on starting and running the generator, see separate generator section.

1. Generator Selector Switch should be "off".
2. Run blower for at least two minutes.
3. Turn "On-Stop" switch to "on".
4. Hold "Start" switch on until engine starts. Voltmeter will indicate when unit is running.
5. Turn Generator Selector Switch to "on".
6. To transfer 120 V.A.C. Panel load to generator, turn "Shore-Ship" switch to "Ship" position. It does not matter whether shore line is connected or not or whether Shore Main Breaker #100 is "on" or "off".
7. To transfer 120/240 V.A.C. Panel load to generator, turn "Shore-Ship" switch to "Ship" position. It does not matter about position of the "Port-Starboard" switch or Shore Breaker #200.
8. It is best to remove load from generator before stopping. This can be done by transferring the "Shore-Ship" switched to "Shore" position and turning Generator Selector Switch to "off" position.
9. To stop generator, put "on-stop" switch in "stop" position. Voltmeter indicates when the generator has stopped.
10. It is recommended that "Anchor Windlass" circuit breaker #131 be kept turned off except while windlass is in operation.

120/240 V.A.C. GENERATOR PANEL

The center section of the A.C. distribution panel is to supply ship power to all the 120 and 240 volt branch circuits on the entire panel.

The generator can be started and stopped with the remote controls at top of the panel. The blower should be run for at least two minutes before and during generator starting.

If the generator engine does not run smoothly (RPM varies) when started, momentarily move switch to "stop" position and then return to "on". This should remedy the situation.

The 180 to 260 voltmeter will indicate when the generator is running. The two 0 to 150 ammeters will indicate the amount of current used in each "hot" line.

Notice that all odd numbered 120 V.A.C. branch breakers receive generator power through the left hand 0-150 ammeter. All even numbers get power through the right hand 0-150 ammeter. This is why one ammeter may register different than the other. All 240 V.A.C. branch breaker draw equal current through both 0-150 ammeters.

The branch circuits "Anchor Windlass" (#131) and optional "Fresh Water Maker" (#132) can be powered only by the generator. There should never be any need to use shore power for such equipment.

Since the standard 30 KW generator has ample capacity it is not necessary to use shore power when the generator is running.

120/240 V.A.C. GENERATOR PANEL
OPERATION

For more details on starting and running the generator, see separate generator section.

1. Generator Selector Switch should be "off".
2. Run blower for at least two minutes.
3. Turn "On-Stop" switch to "on".
4. Hold "Start" switch on until engine starts. Voltmeter will indicate when unit is running.
5. Turn Generator Selector Switch to "on".
6. To transfer 120 V.A.C. Panel load to generator, turn "Shore-Ship" switch to "Ship" position. It does not matter whether shore line is connected or not or whether Shore Main Breaker #100 is "on" or "off".
7. To transfer 120/240 V.A.C. Panel load to generator, turn "Shore-Ship" switch to "Ship" position. It does not matter about position of the "Port-Starboard" switch or Shore Breaker #200.
8. It is best to remove load from generator before stopping. This can be done by transferring the "Shore-Ship" switched to "Shore" position and turning Generator Selector Switch to "off" position.
9. To stop generator, put "on-stop" switch in "stop" position. Voltmeter indicates when the generator has stopped.
10. It is recommended that "Anchor Windlass" circuit breaker #131 be kept turned off except while windlass is in operation.

The switch marked "Automatic-Manual" should be in the "Automatic" position. This is the normal operating mode. When in automatic mode, the converter will shut itself off when the battery is fully charged (there will be no damaging trickle charge). It will also shut itself off when the engine is running.

The switch should never be placed in the "Manual" position unless:

- A. The battery is completely "dead", in which case, it should be placed in the "Manual" position until the converter will keep charging when switched back to "Automatic".
- B. The battery is weak and you need the help of the converter to start the engine. This will override the ignition shut-off feature. After starting, switch back to "Automatic" within one minute to prevent damage to the voltage regulators.

The automatic circuitry in the converter reads the voltage of the batteries. It cannot read the batteries capacity. If your boat is used for extended periods as a living area while tied to a dock, it is highly advisable to put the converter on "Manual" for a 24 hour period once a week, and after checking the batteries for liquid level, return to "Automatic" position. This will insure a "Deep Charge", and will extend battery life.

SENTRY OWNER'S MANUAL

For service and adjustments, see the manufacturer's manual.

AIR CONDITIONING SYSTEMS

Power Sources

All the air conditioning equipment is designed to operate on 220 to 240 V.A.C., single phase, 50 or 60 Hz power.

Power can come from either the generator or the 240 V.A.C. shore line.

All of the branch breakers, # 205 to # 209 should normally be "on".

Mechanical

The four condensers that supply the salon, foreward cabin, master stateroom, and guest stateroom are located on a flat just forward of the main engines. The three stateroom condensers are in front of the starboard engine and the salon condenser is in front of the port engine.

The seacocks, seawater strainers and pumps (2) are located one in front of each engine in the bilge area. The seacocks must be open before starting the system. The strainer should be clean and sealed. The starboard pump supplies the three staterooms and the port supplies the salon. It is automatically turned on by the pump relay, whenever any unit control is turned to "Start" or "Run".

Each condenser has its own seawater discharge through the hull side, the three on the starboard side share the same pump. There should be three streams out the starboard side about amidships. The one on the port discharges through the port side.

When starting systems, it is wise to observe the discharge streams to be sure that pumps are operating properly and that each condenser has its usual full flow. (Normally there may be a slight difference in streams.)

INITIAL CONTROL CHECK (USUALLY DONE BY THE DEALER)

- A. The air conditioner circuit breakers # 205 to # 209 must be "off".
- B. The "start-run" switch in each control must be in "off" position.
- C. Turn the thermostat control from right to left and listen very closely to the control by putting your ear close to it as you turn the knob. While turning the knob, two clicks should be heard about midway through the travel of the knob. If this is heard you will know that the thermostat bellows have not been ruptured and that you may proceed further. If no clicks are heard, contact your nearest service man for Cruisair equipment.
- D. Check the other thermostat control in the same manner.

INITIAL START-UP

- A. With the 120/240 V.A.C. Panel set up as explained previously, turn on the air conditioner circuit breakers.
- B. Turn deck house control to "start" and check overboard discharge outlets to be sure that the pump is circulating the seawater through the condenser/compressor units. When good-sized streams are flowing, you can be sure the pumping system is okay. Power for the pump is obtained from the "line" side of the air conditioner circuit breakers. There are two in-line glass fuses inside the 120/240 V.A.C. Panel that protect the wiring to the pump and another fuse at the pump relay.

- C. With fan set at midpoint (medium speed), check airflow from discharge grills. Adjust louvers, if necessary, to get more flow. Fans must be working properly before turning controls to "run", otherwise the evaporators may freeze.
- D. Repeat operations B & C with master stateroom control.
- E. You are now ready to test each unit fully. Start with deckhouse control.
- F. How to test operation:
 1. Turn control to "start".
 2. For cool, turn thermostat knob to far right (clockwise).
 3. Fan control may be at any setting, but for testing, set at midpoint (medium speed).
 4. Now turn control to "run".
 5. Check air flow from each discharge grill. In about 3 to 5 minutes, according to the temperature, the units should be discharging cold air.
 6. Turn control "off" and wait 10 or 15 minutes before turning thermostat to far left (counter-clockwise) for maximum heat. Never make quick changes from cool to heat or from heat to cool.
 7. Turn control to "start" and then to "run". Check each discharge for warm air after it has been running for a few minutes.
- G. Repeat these operations (1 to 7) with the master stateroom control.
- H. Check out the entire forward system in a similar manner.

Temperature Adjustment

After the unit has been in operation for about 1 hour, the thermostat knob may be moved, a little at a time, until the desired temperature is

obtained. Then, the unit will automatically maintain the temperature, adjusting itself to heat or cool as required.

Power Interruption

If, for any reason the 240 V.A.C. power is shut off momentarily, the unit should be turned "off" for about 10 to 15 minutes before putting it back in operation. Then the knob should be left in "start" for about 5 minutes to allow the water to circulate fully; it can then be turned to "run".

How to Stop Unit

Always use the local control to stop each unit. Never leave the control on "run" and use the circuit breakers on Electric Panel to stop the units.

If you do change the 240 V.A.C. Electric Panel, after air conditioner is stopped, be sure power is restored before turning any of the local controls to "start" or "run".

FUEL SYSTEM

Fueling Instructions

The forward tanks can be filled from either port or starboard fuel deck plates (nearest forward end of the deckhouse). The aft tanks can be filled, either port or starboard, through fuel fills nearest the aft end of the deckhouse.

Before filling, check contents of each tank, using the appropriate valve on the flybridge console.

While filling, tell the dock attendant the approximate amount of fuel to add to the forward and aft tanks. Avoid excessive overflow through the tank vents. Do not use gauges to determine when the tanks are full, their accuracy is limited, especially near the full mark.

The usual safety precautions should be taken while tanks are being filled. Any spills should be cleaned up immediately.

Fuel Tanks

The fuel tanks are welded marine aluminum, suitably baffled and vented. There are four tanks, located in the engine room. Two port and starboard forward, and two port and starboard aft. The usable capacity of each tank is 325 U.S. gallons (1,230 liters). Optional 500 U.S. Gallon tanks are available (1,892 liters.)







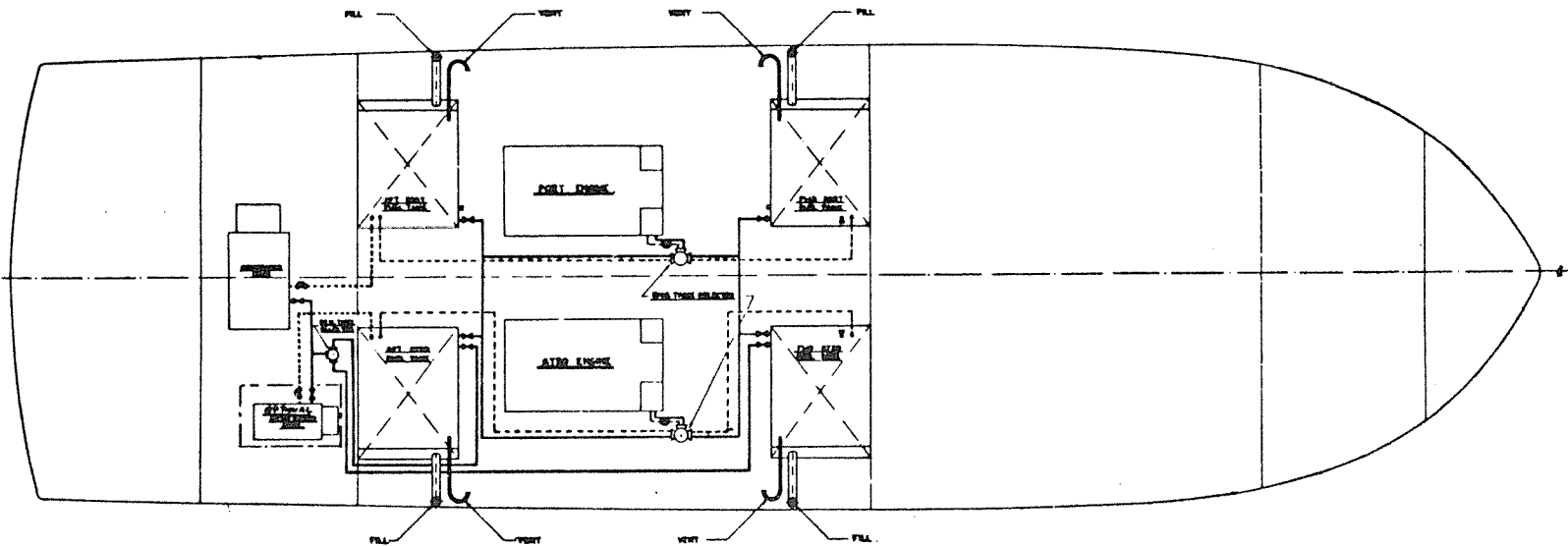



Fuel Supply and Return System

Fuel is supplied to main engines through 6-way valves located on the starboard side, forward of each engine. These allow the engines to be supplied from any tank or all tanks. Simultaneously each valve always returns fuel to the same tank from which it is drawing.

| REVISIONS | | | |
|-----------|-------------|----|------------|
| LET. | DESCRIPTION | BY | DATE APPL. |
| | | | |



NOTES:
 1. FOR FUEL TANK, FILL EVENT SEE SH * 0484065
 2. FOR FUEL CYST. ENG. SEE SH * 0488070
 3. FOR FUEL SVST. DUAL GEN. SEE SH * 0808288

-  4 WAY VALVE
-  3 WAY VALVE
-  2 WAY VALVE
-  CHECK VALVE
-  DIAPHRAGM VALVE
-  FUEL SUPPLY LINE
-  ENG. RETURN LINE
-  GEN. SUPPLY LINE
-  GEN. RETURN LINE
-  PLUG

| | | | |
|---|-------------|-----------|---------------------|
| BERTRAM YACHT MIAMI, FLORIDA, U.S.A. <small>A SUBSIDIARY OF WHITTAKER CORPORATION</small> | | | |
| MODEL | 383 | | |
| TITLE | FUEL SYSTEM | | |
| DESIGN | NONE | PLANT NO. | 5131 |
| DATE | 8/15/54 | BY | J. H. H. / J. H. H. |
| CHKD. | 8/15/54 | BY | J. H. H. / J. H. H. |
| PWA 585 | | | |

Constant Trim

Under normal conditions, the port engine should use the aft tanks and the starboard engine should use the forward tanks.

This will cause the least restriction in the supply lines and also keep the center of gravity where it is designed to be.

FRESH WATER SYSTEM

TANK

A single fresh water tank with a capacity of 300 gallons is located amidships in the lazaret, below the cockpit deck.

DECK FILL

The fresh water fill is located in the cockpit sole. It is not vented overboard, but vented inside the boat. There is also an access plate next to the deck fill for the sender.

TANK GAUGE

Fresh water tank gauge is located in the galley. It will not register unless the fresh water pump breaker #54, on the 32 V.D.C. Panel is turned on. The gauge is not accurate while the tanks are being filled.

WATER PRESSURE PUMP

Power for the pump is supplied by circuit breaker #125 on the 120/240 V.A.C. Panel. The pressure switch, near the pump is set to cut in at 30 pounds and to cut out at 50 pounds. The pump is normally located on the port side in the generator room. Depending on options installed the pump may be installed on the starboard side of generator room if necessary. It is a time-proven centrifical type that will give excellent service with minimum attention. The manufacturer's instructions for maintenance, lubrication and winterization should be followed.

A dry tank switch shuts off power to the pump. Tank should be re-filled before restarting the pump.

EXPANSION TANK

This tank has been pre-charged with air to the normal cut-in pressure 30 pounds, before the tank was filled with water.

To check this, turn off the pump circuit breaker, disconnect shore water supply if in use, and open the water fill line in generator room until the tank is drained. Measure air pressure with a standard tire gauge on top of the tank. It should be between 45-50 P.S.I. in the inner tank.

WATER TANK

The water heater is located in the engine room outboard of the port engine at the forward end. Capacity is 30 gallons.

Power is from the 240 V.A.C. Panel, breaker #202. Do not turn on power until the water system is pressurized and the heater is full of water (since this could have been drained for winterization).

To fill the heater, open one of the hot water faucets; when water begins to flow, you will know it is full.

You may want to purge the rest of the hot water and cold water systems. Just open the faucets individually, until all air is expelled.

HEATER CONTROLS

When ready to use, be sure circuit breaker #202, is "on" and that the switch on the heater is "on". Inside this switch box is a thermostat that is pre-set at 150°F. There is also a "reset" button that will require pressing if the heater overheats. A relief valve is also provided on top of the heater that will open if pressure exceeds 125 pounds or if it gets hotter than 212°F.

Dockside Water Supply

In the cockpit located on the pilaster, you will find a dockside water connection, one of each side of the boat. These are connected through a pressure regulator to the fresh water system, on the discharge side of the pump. When dock water is available, it is not necessary to use water in the tank or to operate the pump. Turn Fresh Water Pump circuit breaker "off". The tank cannot be filled by using this connection.

Laundry Equipment

The washer and dryer is optional. If installed, the washer is to the port side of the cabin step and the dryer is to the starboard side of the step, in the cockpit.

Washer drain is through the hull side; an air inlet must be maintained above washer outlet in order to break any siphon condition.

Ice Maker

When the boat is not in use and power to the ice maker is shut off, remove all ice cubes, otherwise, they will melt and drain onto the deck. Prop door open in order to dispel any orders.

Winterizing the Water Supply

Follow suggestions given in Pump Instruction Sheets and in Maintenance Section of this manual. If it is desired to drain the tank, disconnect the piping at the bottom of the tank. Water will drain into the bilge, where it can be pumped out with the bilge pump.

| REVISIONS | | | |
|-----------|-------------|----|------|
| NO. | DESCRIPTION | BY | DATE |
| | | | |

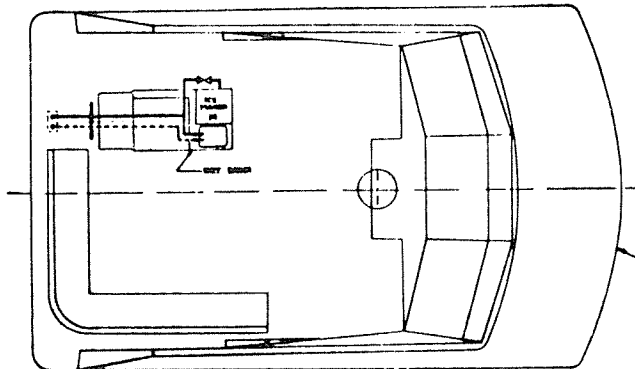

FLYBRIDGE

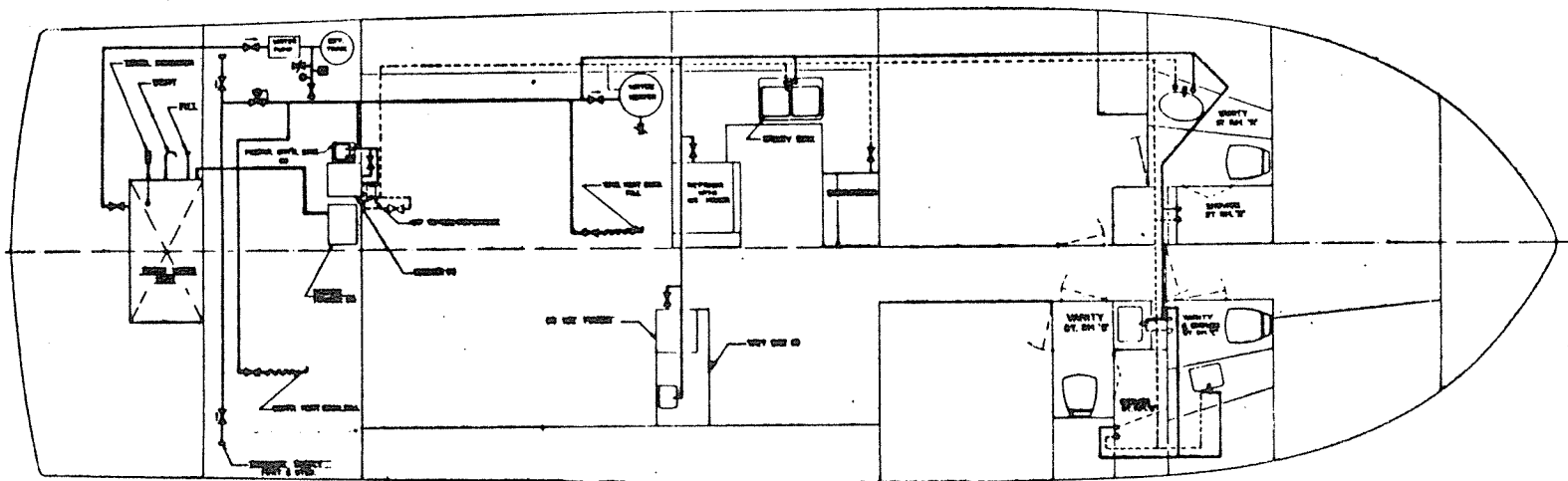

NOTES:
 1. MARK (H) INDICATES OPTION
 2. FOR 5/8" WATER W/WT USE 3/4" CONNECTION
 3. FOR 1/2" WATER USE 3/8" CONNECTION
 4. FOR FLYBRIDGE AND COCKPIT USE 1/2" CONNECTION
 5. FOR WASHING FROM SINK, USE 3/4" CONNECTION
 6. FOR WASHING FROM HOT WATER USE 3/4" CONNECTION
 7. FOR WATER PUMP USE 1/2" CONNECTION

- SAFETY VALVE
- VALVE
- CHECK VALVE
- PRESSURE REGULATOR
- COLD WATER LINE
- HOT WATER LINE
- SUPPLY/RETURN WATER LINE
- PRESSURE GAUGE
- PRESSURE SWITCH

| | | | |
|---------------------------------|-----|----------|------|
| BERTRAM YACHT | | | |
| MIAMI, FLORIDA, U.S.A. | | | |
| DESIGNED BY BERTRAM CORPORATION | | | |
| MODEL 183 | | | |
| TITLE | | | |
| FRESH WATER SYSTEM | | | |
| DATE | BY | PLAN NO. | REV. |
| 12/74 | WJH | 5091 | |
| DATE | BY | | |
| | | | |

TOILETS

The Crown toilet/Lectra-San units (standard equipment) installed on your 58' Convertible are a combination of two separate units to supply a flow-thru treatment that meets Coast Guard requirements.

The Crown head operation is controlled by a push button that starts and stops the head motor. The button needs to be depressed only long enough to complete a normal flushing cycle and the bowl is clean.

The Lectra-San treatment unit used in conjunction with the Crown head utilizes two operating principals:

1. Reduction of solid waste to indiscernable particles.
2. Oxidation of waste matter and destruction of odors and bacteria.

OPERATION

1. The Lectra-San unit operation is automatic, the knob on the control unit is turned clockwise a full 240° to engage the timer and turn on the flush/pre-treat light before flushing the toilet.

2. Flush the toilet using the push button with minimal amount of water required to clear the bowl. This will normally take six to ten seconds.

3. After about two and one-half minutes, the operating cycle will complete and the system will automatically shut down.

4. Toilet is now ready for the next use.

NOTE: The toilet can be used during the treatment cycle, but the flush must be deferred until the operating lights are "off" and the system is activated again by a clockwise turn of the knob on the control unit. IMPORTANT: Serious damage can occur to the system if the Lectra/San is operated without water in the treatment unit. If the boat has been out of the water for some time so that no water is in the Lectra/San unit for one reason or another, it is recommended to recharge the unit.

To recharge the unit with water once relaunched, depress the flushing button on the toilet for about 15 seconds or until sufficient amount of water has flowed into the system.

SALT TANK

The treatment in the Lectra/San unit utilizes salt from the saltwater of our oceans and bays to treat the waste. If the unit is in the treatment cycle and the needle of the control unit indicates in the low side of the gauge it means there is inadequate salt content in the treatment unit. This could be caused by being in brackish water or on fresh water. When this occurs it will be necessary to utilize the salt feed tank.

To fill salt feed tank:

1. Close off valve on the salt feed tank.
2. Disconnect tubing from tank and remove tank.
3. Add a five pound bag of ordinary table salt to the empty salt tank.
4. Fill the salt tank about one-half full with hot water and stir or shake for a minute or two to dissolve the major portion of the salt.
5. Fill salt tank to the neck with hot water and stir or shake for about three or four minutes to dissolve remaining salt.
6. Replace salt tank in its proper location and reconnect tubing.
7. Adjust feed control valve to position for your type of water.

Fresh water.....Full Open.

Brackish water.....3/4 Open.

Sea Water.....Closed

LOCATION OF COMPONENTS

The salt feed tank for the forward stateroom head and master stateroom head along with their corresponding Lectra/San units are located under the hatch in the forward companionway even with the forward head door.

Salt feed tank and Lectra/San unit for the guest head are located under

the hatch in the companionway just aft of doorway into the guest head.

For other general information and trouble shooting procedures refer to your Lectra/San owners manual that is part of your ships papers, brochures, and folders.

VENTILATION SYSTEMS

ENGINE ROOM HEAT REMOVAL SYSTEM

Control

Circuit breaker # 62 , marked "Auto Blowers" on the 32 V.D.C. Panel should be "on". A thermostatically controlled switch is located on the overhead near aft end of the main engines. The pointers on Fan Scale should be set at 100° Off and 110° On. The Limit switch is not used. On top of the control is a manual switch that permits turning on the blowers regardless of temperature. When leaving the engine room, be sure switch is set to "Auto" position.

Blowers

These blowers have intakes at the top of the engine room where they are most effective for heat removal. They discharge through the same vents on deck as the bilge blowers.

ENGINE ROOM BILGE BLOWERS

Control

These blowers receive their power from circuit breakers # 51 and # 52 marked Port Blower and Starboard Blower, on the 32 V.D.C. Panel. Switches are located at the flybridge console. Each switch has a blue pilot light that indicates the blowers are running.

Blowers

These are located in the engine room all the way forward. They discharge through the same vents on deck as the heat removal blowers.

Operation

Blowers should be run for about 2 to 5 minutes before starting main engines to remove any fuel oil fumes in the bilge.

GENERATOR BILGE BLOWER

Control

This blower receives its power from circuit breaker # 43 on the 32 V.D.C. Panel. Switch is located on the Generator Section of the 120/240 V.A.C. Distribution Panel.

Blower

This is located near the generator. The intake tube leads to the base of the engine. Discharge is through a louvered vent on the port side of the hull. If the optional 15 K.W. is installed, its discharge is through the starboard side of the hull.

Operation

Blower should be run for at least 2 minutes before starting generator to remove any fuel oil fumes in the enclosure.

TOILET BLOWERS

Each toilet space has a small exhaust blower. Switches have pilot lights to indicate blowers are operating. Blowers are all 32 V.D.C. and get their power locally from the lighting circuit.

GALLEY RANGE VENT

The range has a built-in exhaust fan and hood over the oven. The fan is activated by pulling the handle located at the top, in the center. The filter should be cleaned regularly.

LAUNDRY VENT

The dryer vent is ducted through the hull, starboard side.

REVISIONS

| LET. | DESCRIPTION | BY | DATE | APPV. |
|------|---|-------|----------|-------------|
| A | 1. ADDED ITEM 34 2. CHNG'D NOTE ON SHEET 2 3. ADDED SECTION -06 | A. E. | 10.25.76 | [Signature] |
| B | 1. P/N 14486 - CHNG'D QTY, WAS 1 2. P/N 14487 - CHNG'D QTY, WAS 1 3. ADDED P/N 14983 4. ADDED P/N 1A1216 | A. E. | 11.10.76 | [Signature] |

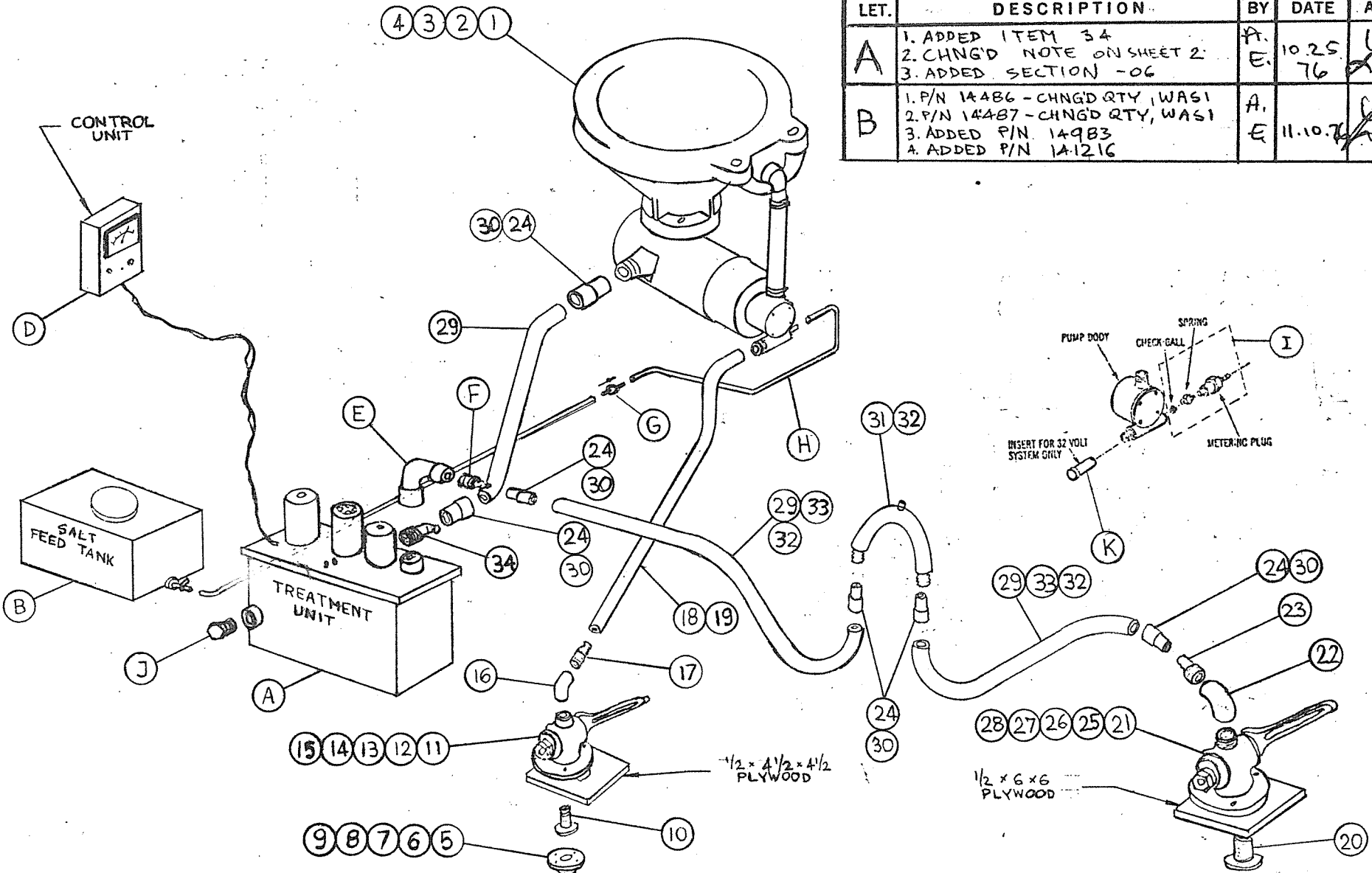

BERTRAM YACHT
MIAMI, FLORIDA, U.S.A.
A SUBSIDIARY OF WHITTAKER CORPORATION

MODEL 464, 467, 587, 585
TITLE
TOILET RARITAN
W/LECTRA/SAN 32V
BM 07A5049

| | | | |
|--------------------------------|-------------------------------|--------------|---------------------------------|
| <input type="checkbox"/> BASIC | <input type="checkbox"/> SUP. | POWER | <input type="checkbox"/> OPTION |
| ECN OR REL. NO. | | PLAN NO. | REV. |
| BY: Adam E. | APPVD: [Signature] | 07A 5049 | B |
| DATE: 5.28.76 | DATE: 6/15/76 | SHEET 1 OF 5 | |

FILE INST'L

BILGE AND MISCELLANEOUS PUMPS

ELECTRIC BILGE PUMPS

Automatic-Manual Pumps

The aft pump is located at the transom below the cockpit deck. The forward pump is under the passageway sole, forward of the engine room. Both pumps have float switches that permit automatic operation.

Power from above switches is from circuit breakers # 31 and # 34 on the 32 V.D.C. Panel. These breakers have power even if Main Breakers, # 7 and # 8 are off.

Switches for the pumps are located at the flybridge console. They are normally left in "Auto" position at all times. Pilot lights will indicate whenever pumps are running in either "Manual" or "Automatic" mode.

Pumps and float switches should be cleaned periodically and checked to assure proper operation.

Engine Room Bilge Pump

A small pump at the aft end of the engine room is connected by hose to a strainer in the sump above keel. There is also a float switch that will automatically keep the bilge dry.

Power comes from breaker # 33 on the 32 V.D.C. Panel. It should be left "On" at all times.

The pilot light beside the breaker indicates when the pump is running. There is no manual switch for this pump, except for the circuit breaker.

The engine room forward and aft bulkheads are water tight in the bilge area.

MECHANICAL BILGE PUMP SYSTEM

Pump

This is a 62 G.P.M., 1½" Jabsco impeller pump with manual clutch driven off forward end of the starboard engine. The pump should never be run dry for longer than 30 seconds, as the heat from friction will destroy the impeller.

Valve Manifold

Near the pump are three valves that control the suction lines leading to forward, engine room, and aft compartments. The first one (forward) is for the forward compartment. The center for the engine room, and the last one for the aft compartment (generator room). These valves should always be closed. If an emergency occurs open only the valve for the flooded compartment. If any other valve is even partially open, the pump will not lift water, only suck air from the dry compartment. It is best to hold your hand on the face of the pump; as soon as the pump runs dry, this face will get hot -- stop the pump immediately.

Strainers

The intake strainer for the forward compartment is near the forward electric bilge pump. The strainer for the engine room is in the sump above keel. The strainer for the aft compartment is just aft of the aft engine room bulkhead, in the generator room.

SHOWER SUMP PUMP

The crew quarters shower and the guest stateroom both drain into a common

sump located beneath the passageway sole. Pump gets its power from breaker #56 on the 32 V.D.C. Panel. As long as the power is on, the pump is automatic in operation - discharge is controlled by a float switch in the sump. Check the float occasionally to be sure it is operating properly.

MASTER STATEROOM BATH SUMP

A similar sump, pump and switch installation is located adjacent, but not connected to the other sump. Power is from breaker # 56 on the 32 V.D.C. Panel.

DECK WASH DOWN PUMP

A 1 H.P. motor and pump unit, manufactured by Sears, Roebuck and Company, Model No. 390.25130 is installed outboard of the port engine for the sea system. It has a pressure switch and pressure tank. When a faucet is opened and pressure drops, the pump will start. There are four faucets located as follows: One in the cockpit port side, one in the cockpit starboard side, one on the sink at the preparation center, and one in the port side forward mounted on the toe rail. If any problems arise, consult your manufacturer's manual.

If you have the optional baitwell, it also is supplied by this pump. Power is from circuit breaker #203 on the 120/240 Volt Panel.

WINDSHIELD WIPERS

On the flybridge windshield there are three individual windshield wipers one for each section. A fresh water wash system is also provided, supply is from the boats' fresh water system. The controls are located on the flybridge instrument panel, with push-pull switches for wiper control and toggles for

utilizing the washers. These wipers are 12 V.D.C. and get power from circuit breaker #20 on the 12 V.D.C. Panel.

FIRE EXTINGUISHING SYSTEM

This Fire Detection and Extinguishing System provides high speed detection, warning, and extinguishment of engine room fires.

Carbon Dioxide is normally colorless, except that, when discharging, it resembles a cloud of steam. When inhaled in small amounts, it produces a tingle in the nostrils the same as experienced when drinking soda water. It is a non-conductor of electricity, is non-corrosive, and non-injurious to all substances and although heavier than air, it may be easily diffused and removed by ventilation. Unlike air, it does not contain oxygen in any form available for supporting combustion or for sustaining human life in breathing.

"Fast" fires, such as engine room, oil, or paint fires, are quickly extinguished by flooding the area with carbon dioxide gas. This reduces the oxygen content and creates an inert atmosphere which smothers the fire. In addition to its smothering action, carbon dioxide is aided in extinguishing fire by its cooling effect.

Since a person cannot breathe but will suffocate in an atmosphere of carbon dioxide, caution must be taken before entering any space filled with this gas. Thoroughly ventilate the space into which the gas has been discharged to make certain that all portions contain only fresh air.

If it be necessary for a person to enter a space before it is thoroughly ventilated, he may do so by using a fresh air mask or other type of self-contained breathing apparatus. DO NOT USE a filter type of mask or a canister gas mask. No one should enter such a space without a person as observer and standby located outside the space.

Should a person be overcome by carbon dioxide, it is essential that he be immediately rescued from the space containing the gas. To revive a person so overcome, give him plenty of fresh air and apply artificial respiration

(as in the case of drowning) without the use of carbon dioxide as a stimulant.
Call a physician.

Agent

This system uses CO₂, carbon dioxide, which is highly effective in extinguishing Class A, B, and C fires. It is non-corrosive, non-conductive, and leaves no residue.

Detectors

There are three detectors, two in the engine room and one in the generator room.

Cylinders

There are two 50 pound CO₂ inter-connected, located in the engine room forward. The six discharge nozzles are in the bilge areas, four in the engine room and two in the generator room. When the system is activated it will flood the engine room and generator room, simultaneously.

Alarm System

The Bertram Alarm System heat detectors and smoke detectors will not activate the fire extinguishing system.

Cylinder Check

To check cylinders to see if they have been discharged without your knowledge, visually inspect the pneumatic control head (located on top of the cylinder). In about the center of the control head a round indicator can be observed. It has two positions, SET and RELEASED. The red arrow on the indicator will point to RELEASED if they have been discharged.

CAUTION: Do NOT attempt to re-set yourself. See your authorized Kidde

Distributor for re-activating the system.

As you enter the engine room to check the oil and water, a glance will tell you the status of the system. Annually, the cylinders should be removed and weighed to determine any agent loss, and refilled as necessary. This should be accomplished by an authorized distributor.

Manual Pull Control

In the cockpit, near the step to the deckhouse is a hand pull control that will discharge the system mechanically.

CAUTION: Make sure no one is in the spaces protected (the engine room and generator room) before pulling the handle! CO^2 will not support life.

PNEUMATIC SYSTEM

This system is primarily for the horns, but fuel gauging is also tapped from the reservoir, as the levelometer system operates on air pressure differential. Valves are provided to select individual tanks.

The system is composed of an engine driven compressor mounted on the port engine and tank reservoir.

Fuel Gauging

To determine fuel level in the tanks, select the proper valve for the tank you are checking and open it. Other valves should be closed. The gauge will indicate the contents in 1/8 increments.

In the unlikely event of air pressure failure, a manual system is also provided. The supply valve from the compressor has to be closed to operate the manual system. Open the valve for the desire tank. Push the knob in and turn counter-clockwise to release the plunger. Operate the plunger in and out until the indicator stops moving. To read other tanks follow the same procedure selecting the proper valve. To lock, simply push the plunger in all the way and turn clockwise.

| REVISIONS | | |
|-----------|---|---------------|
| LET | DESCRIPTION | BY DATE |
| A | CHANGED BM # 350/002 (WAS) BM # 300/002 | 1/10/74 E/W/H |

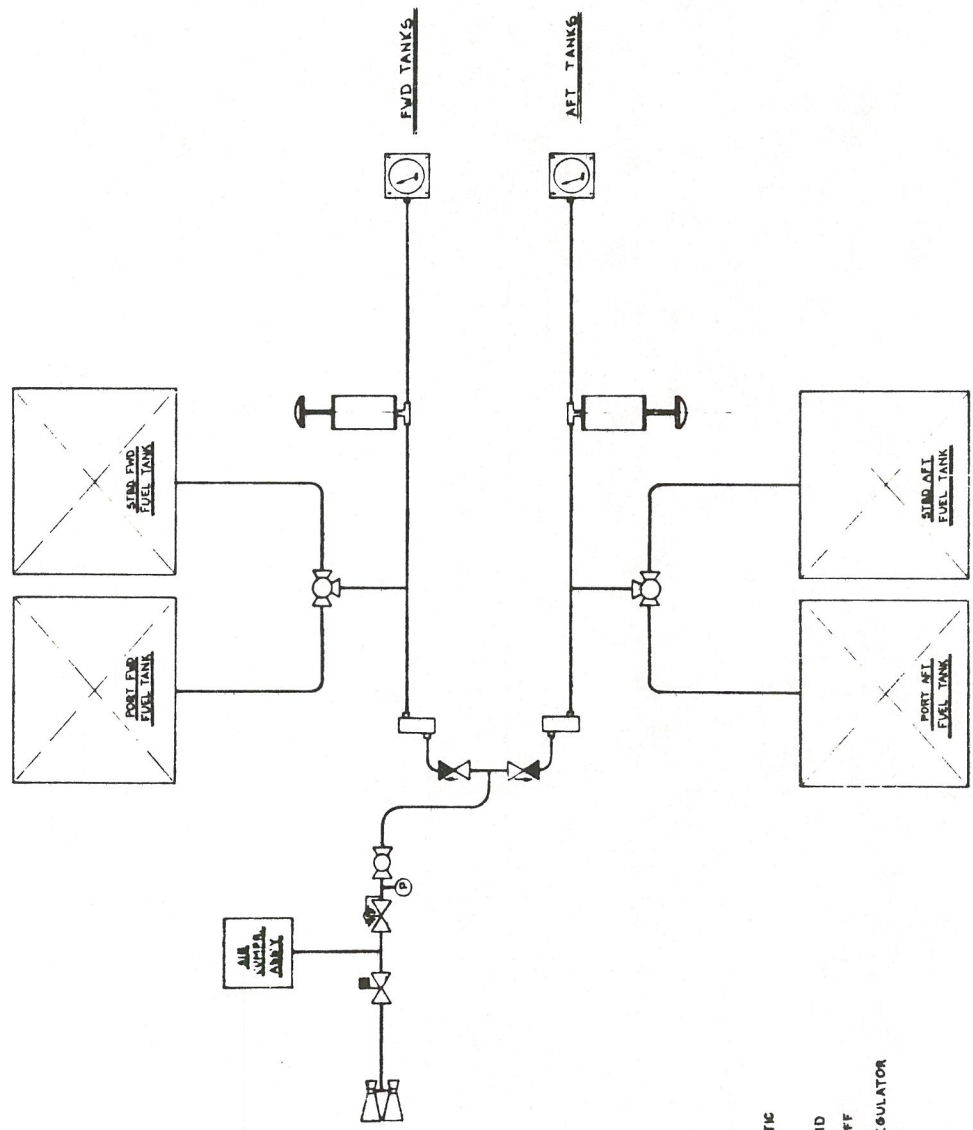

NOTES:

1. AIR COMPR. ASSY INCLUDES COMPRESSOR, TANK, CHECK VALVE & GAUGE.
2. FOR DETAILS OF AIR HORN INSTL. SEE BM # 350/001
3. FOR DETAILS OF FUEL GAUGE SYST. SEE BM # 300/002.

- HORN, PNEUMATIC
- VALVE, SOLENOID
- VALVE, SHUT-OFF
- PRESSURE REGULATOR
- VALVE, CHECK
- VALVE, CHOKE
- VALVE, SELECTOR
- PUMP, HAND
- GAUGE, FUEL
- AIR TUBING
- GAUGE, PRESSURE

| | |
|--|-----------------------------------|
| BERTRAM YACHT MIAMI, FLORIDA, U.S.A. | |
| A SUBSIDIARY OF WHITTAKER CORPORATION | |
| MODEL TITLE | 565 HORN AND FUEL GAUGE SYSTEM |
| SCALE | NONE |
| BY | APPROVED |
| DATE | DATE |
| PLAN NO | REV |
| C 5280 | A |
| FILE | 5-85 |

COMMANDING YOUR BERTRAM

Pre-Starting Instructions

The following are routine procedures that should be followed each time you take your Bertram out.

1. Always check fuel supply.
2. Never start engines without first running bilge blowers and checking the bilge by smell for fuel vapor.
3. Make sure the seacock for the engine cooling water is open. The rubber impellers in the pump will not last long when run dry.
4. Make sure the fuel valves at the tanks and at the engines are open.
5. Check engine and reverse gear oil. Make sure they are at the proper level.
6. Check water level in expansion tank of fresh water engine cooling.
7. Also check the generator cooling, fuel and lube oil systems.

Starting Instructions

1. Main breaker must be in "ON" position. (Port Battery Main and Starboard Battery Main.)
2. Circuit breaker marked ENGINE must be in "ON" position. (Port Engine and Starboard Engine.)
3. Check clutch control lever to insure that clutch is in neutral.
4. On-Stop switch to "ON" position--both stations if your boat has flybridge controls.
5. Actuate start switch till engine starts. Note, do not hold starter switch down for more than 30 seconds, or damage will occur to starter motor.

Maneuvering

Your Bertram has twin propellers rotating in opposite directions in order to balance the torque. You can engage one engine in forward gear, and the other in reverse gear. This will turn the boat completely around in its own length if the rudder is left in the center position. You can, of course, make such a turn in either direction. Port engine forward and starboard engine in reverse spins you to starboard. Starboard engine forward and port engine in reverse spins you to port. You can accentuate the spin by full rudder in the spin's direction.

In docking, approach at a slow speed, and at a 30 degree angle. When your bow is about 10 feet from the dock, put the dock-side engine in neutral, and the far-side engine in reverse. This will reduce your forward movement and bring your stern alongside the dock. Usually the docking can be accomplished with the clutches alone. No steering or use of throttle is required.

Stopping Engines

Simply turn On-Stop switch to STOP. There is, in addition, an emergency shut down system. In case of electric failure or other emergency, simply pull handle marked "Emergency Stop". (NOTE: Use emergency only as a last resort.) This can only be reset from the after end of the engine blower, by turning a small projecting handle that re-opens the air valve inside the blower inlet housing. For further details see the GM Manual.

Cruising Speeds

As you increase speed, the boat will increase her angle of trim. That is, the bow rises. As a rule, top cruising speed R.P.M. should be 10% to 15%

less than the top RPM. Consult your engine manual.

Some additional considerations: engine performance will be affected to a slight degree by atmospheric conditions. You will find your engines develop less power in warm air temperatures. Similarly, dry air reduces power, as will high altitudes.

The famous Bertram V Hull cushions pounding by slicing rather than slapping waves. You'll be able to go out in weather that keep ordinary boats at their moorings. But, even Bertrams can encounter extreme conditions that call for sensible seamanship, i.e. good common sense. While your Bertram will withstand far greater punishment than you will probably ever subject her to, speed should be reduced under severe conditions in the interest of your comfort and to reduce needless strain on the engines.

Cruising

In order to avoid going aground or damaging underwater gear, it is important to know the draft of your Bertram, or the amount of water you must have under you at all times. Draft will vary depending on how many people, and how much equipment or personal effects you are carrying. What's more, your draft will be somewhat less in salt water than in fresh water.

You can determine maximum draft by measuring the freeboard from the deck to the water line at the center of the transom. Subtract this freeboard from the hull depth at the transom (see Docking Plan in this manual) to get the hull draft at the transom. Add depth of underwater gear as indicated in Docking Plan, and you have the maximum draft. Record the figure where you can refer to it quickly.

If you plan to travel waterways crossed by bridges, you'll also want to know the height of your Bertram from the waterline. Take your measurement when your Bertram is lightened of its fuel, passengers and equipment. This will give you a small safety factor when the boat is loaded.

For best results try to maintain the original trim of the boat. You can do this by noticing her trim carefully when she is first launched, her tanks are filled and before extra equipment has gone aboard. Of course, all gear and equipment should be properly stowed while cruising.

Calling at Ports Away from Home

You are not likely to have trouble with shore current in the United States. (However, you should be somewhat careful when using 30 amp, 120 volt, service with a pigtail adapter.) This is a low capacity adapter and should not be used when demand exceeds 3300 - 3600 watts. When cruising abroad, check shore power for 120/240 volt single phase, A.C. 60 cycles. See section on Electrical System for specifics on connections for shore current. Shore power with 120 V.A.C., 50 cycles can be used but a power loss will be experienced. If in question, avoid damage, use your generator.

Also, when cruising abroad, try to purchase fuel equal to American standards. (See Diesel Fuel Oil Specifications in the Detroit Diesel Operators Manual.) Carry extra fuel and lube oil filters with you, since replacement may be necessary.

In some areas, it is advisable to use water purifying tablets of the iodine type. Be sure to take these with you when cruising to places where the water supply is suspect.

Leaving your Bertram

The following are procedures to follow when leaving your boat overnight or for a short period of time:

1. Lock all engine circuits, by turning off engine circuit breakers and locking the 32 V.D.C. panel door.
2. Lock all doors, windows, and hatches.
3. Make sure mooring lines are well secured with adequate allowance for the tides.
4. Fender and spring lines set.
5. Leave bilge pumps in auto position.

The following steps should be followed when leaving your boat for longer periods of time, such as a week or more:

1. Follow all of the above steps.
2. Turn main circuit breakers to OFF position.
3. Close all seacocks or valves.
4. Turn off fuel valves.
5. Open vent in deck hatches.
6. Crack window in deckhouse for ventilation.
7. You may wish to leave refrigerator or freezer running.

MAINTENANCE

Periodic Maintenance

The maintenance of Bertrams depends to a great extent on the conditions under which the boat is used. Adequate ventilation of the cabin during periods of non-use will reduce the interior maintenance, and keeping the exterior waxed will minimize the exterior maintenance.

In this section a suggested preventive maintenance program is set forth for the boat under "average" conditions, and if this program is used it should be used in conjunction with the periodic maintenance recommended in the respective operating manuals for the engines and generator.

CAUTION: When washing and hosing down the deck area, make sure caps on the shore power receptacles are closed.

Daily

1. Pump bilges as required.
2. Ventilate engine compartment.
3. Check engine lubricating oil levels.
4. Check engine coolant levels.
5. Check generator lubricating oil level.
6. Check fuel, water, and oil systems for leaks.
7. Visually check raw water strainers for dirt accumulation.

Clean as necessary.

8. With engines running, check engine circulating water by observing engine exhausts. Water should be exhausting along with the gases.

9. Check battery water.

10. Top off fuel tanks and water tanks at end of day's operation.
11. Wash down boat with fresh water.

WHEN YOU FIRST TAKE COMMAND AND THEN EVERY 100 HOURS OR 60 DAYS (WHICHEVER COMES FIRST.)

EXTERIOR

1. Visually inspect exterior fiberglass finish; clean and wax.
2. Inspect all hardware and apply protective polish. Tighten any loose fittings. Lubricate locks and latches.
3. Inspect condition of all varnished areas. WARNING: Do not let varnished areas deteriorate, otherwise wood will turn dark, requiring complete stripping and refinishing. To properly maintain, light sand and revarnish with good grade of marine varnish.
4. Inspect all exterior seat cushions. If wet, remove covers and air dry in sunlight all polyfoam and covers. Clean covers with mild soap solution or light Clorox solution. Wash any cleaning materials off with fresh water.

INTERIOR

1. Completely air out the boat.
2. Inspect all life jackets.
3. If any mildew is found, thoroughly wash down area with Clorox solution.
4. Inspect and operate all drawers and doors. Slight adjustment may be necessary on doors and drawers due to expansion from moisture. Drawers can be made to slide easier by using wax under runners.
5. Check all port lights. Lubricate dog threads with Vaseline.
6. Check all fire extinguishers for full charge.
7. Check first aid kit.
8. Check emergency provisions (food, water) etc.

STATEROOMS AND SALON

1. Check operation of lights.
2. Check 110 volt duplex plug-in for operation.
3. Check hatches for operation and watertight fit.

TOILET ROOMS

1. Check operation of light.
2. Check 110 volt duplex plug-in for operation.
3. Inspect the toilet for proper operation.
4. Inspect hot and cold water faucets for leaks and operation. Check drains for pluggage or leaks.

GALLEY

1. Check hot and cold water faucets for operation. Check drinking water outlet.
2. Inspect sink drain for pluggage and leaks.
3. Check lights and duplex plug-ins for operation.
4. Clean and check stove for operation.
5. Check refrigeration and freezer for operation. Defrost and clean refrigerator and freezer with a solution of baking soda. Leave door open.

ENGINE COMPARTMENT

1. Follow periodic preventive maintenance for engines and marine gears as specified in engine manual.
2. Inspect stuffing boxes.
3. Inspect exhaust hoses and hose clamps.
4. Check raw water seacocks. Lubricate with Vaseline (Open and close.)
5. Clean raw water strainers.
6. Check engine mounting bolts to see that they are tight. If bolts

are found to be loose, realign engine. If coupling must be broken loose, lubricate coupling bolts and coupling faces with Vaseline.

7. Check all hoses on engines, and hose clamps. Inspect for leaks (important). Check alternator belts.

8. Check fuel lines, flare nuts, and valves for leaks.

9. Check control cable brackets for tightness and lubricate as necessary.

10. Check electrical connections and clean if corroded. (Paint with liquid tape)

11. Check exhaust blowers for operation and hoses for leaks.

12. Check all wiring to see that it is not rubbing or insulation worn off (also battery cable.)

13. Check all gauge senders, alarm lines and fittings for leaks.

14. Check all fresh water system lines and fittings for leaks.

15. Check fresh water pump for condition and operation.

16. Check hot water tank and all connections for leaks.

17. Check electrical connections for tightness and corrosion.

18. Lubricate control heads with Vaseline.

19. Test alarm system (lights and bell).

AS REQUIRED

Pull boat out of water, scrub, if necessary.

Repaint bottom with anti-fouling, if necessary. Note, never paint on ground plate or transducer.

STORING YOUR BERTRAM

DRY STORAGE

1. Indoor storage is generally preferred, if there is good ventilation, and if the location is otherwise safe and dry. However, outdoor storage may be all that is available, or economically practical.
2. (For any special instructions for covering Bertram for outdoor storage, refer to Docking Plan.)
3. To keep bilge dry, remove all bilge water and open all valves and/or seacocks.
4. Drain all tanks, water lines and pumps of water to prevent damage from freezing. Add anti-freeze to any low position lines that can't be drained. In warm climates draining will prevent water stagnation. (See Winterizing procedure)
5. Open windows, port lights and hatches sufficiently to allow air to circulate. Also leave locker doors and drawers open.
6. Defrost and dry out refrigerator and freezer, and prop doors open.
7. If possible, remove mattresses and cushions, clean and store in a dry place. If they must be left aboard, prop up on one edge for maximum ventilation.
8. Synthetic material lines need only proper handling and occasional cleaning. Natural fiber lines should be dried and kept in a well ventilated place.
9. With all toilets, water delivery and discharge lines drained, apply a light coat of oil to all metal parts. CAUTION: Do not oil any rubber or leather parts.
10. To protect chrome, stainless or aluminum deck hardware, first remove any salt deposits with water. Then clean with a good quality non-abrasive type metal cleaner. Finally, give items a light coat of grease.
11. Check propellers for nicks, dents, and bend blades. Check struts and shafts also. Any replacement or repairs should be made at this time instead of during the spring rush.

12. Be sure all linkages of steering, engine and other controls are free and well lubricated.

13. Disconnect shafts from engines.

14. Remove batteries and make arrangements for storage and periodic recharging

WET STORAGE

All the above applies, except that valves and seacocks should remain closed, and the electrical master switch should be placed in the "off" position.

FITTING OUT

In order to insure maximum pleasure and enjoyment from your Bertram yacht, after an extended lay-up, a thorough check of the boat and equipment is necessary with maintenance being done as indicated. The following list should serve as a guide for the more important items to be accomplished (not necessarily in the order to be done.)

PRE-LAUNCH

1. Thru-hull strainers clear and secure.
2. Shafts should turn freely.
3. Secure propeller nut, jam nut, cotter pin.
4. Do rudders fit well in rudder port?
5. Are set screws on struts in place?

AFTER LAUNCH

1. Are seacocks or valves free and operable?
2. Are supply and discharge lines secure?
3. Are fittings tight?
4. Make sure stuffing boxes are adjusted and locked.
5. Check shaft alignment.
6. Make sure packing glands are adjusted and locked.
7. Are bilge pumps working?

8. Are bilge blowers working?

ELECTRICAL SYSTEM CHECK

1. Batteries are properly charged at 1.260 sg. If below 1.220 sg., have charged.
2. Engine wire looms secure, away from exhaust manifold, connections tight.
3. Check the following standard and optional electrically operated equipment to make sure each is working properly.

Navigation Lights

Radio

Ships Lighting

Auto Pilot

Auxiliary Generator

Depth Finder

Converter

Radar

Horn

Shore Line and Polarity Light

Wipers

Shore Line Transfer Switch

Water Pressure System.

Stove and other electrically operated galley equipment.

ENGINE CHECK

1. Fuel lines and cooling lines secure and tight fitting.
2. Exhaust fittings secure and tight.
3. Engine coupling, lock wire, lock washer, key in place.
4. Engine mount fastening tight, locked.
5. See engine manual for service.

CONTROLS CHECK

1. Clutch adjusted, fittings secured
2. Throttle adjusted, fittings secured.
3. Emergency shut down adjusted, fittings secured.
4. Steering is positive, linkage secure, rudders move freely.
5. All gauges and instruments should be operating properly.

MAINTAINING YOUR BERTRAM

CARE OF FIBERGLASS CONSTRUCTION

The fiberglass construction which makes up the hull consists of several parts. The exterior layer gelcoat is a special polyester resin into which coloring pigments have been incorporated to give built-in color. Just beneath the gelcoat is a series of glass fabric laminations bonded together by a chemical action, and the part is a one-piece unit. The outside gelcoat - approximately 0.015 inch depth - gives the fiberglass part its glossy finish. The following recommendations will help you keep this unique material in the same condition it was when it left the factory.

SEASONAL CARE (AT FITTING OUT TIME)

1. Clean surface with soap and water.
2. Treat with an automotive type rubbing compound. Use lightly.
3. Wax and polish the surface with an automotive type wax. Some modern products give you rubbing and waxing action in one. These are also acceptable

LOSS OF GLOSS

To restore the glossy appearance of the gelcoat surfaces, a light buffing may be advisable. For hand buffing, use a slightly abrasive rubbing compound similar to Dupont No. 7. If a power buffer is used, Mirro-Glaze No. 1 or similar product is recommended. After buffing, the surface should be waxed and polished as described above for Seasonal Care.

STAINS

The fiberglass gelcoat surface is non-porous and therefore highly resistant to stains. Most can be removed easily with household detergent. Crayon, lipstick, or shoe polish can be removed with plain alcohol.

Ink spots will come off with Ajax or a similiar detergent. While penetrating stains are very uncommon, some products with unusual chemical contents may go too deep for ordinary methods of removal. In such cases, weak solutions of acids or alkalies, such as hydrochloric acid or ammonia can be tried. These may, however, produce a slight discoloration in the gelcoat. If none of the above methods are successful, it may be necessary to sand down through the gelcoat to remove the stain. This will require refinishing. (See Below)

SCRATCHES AND ABRASIONS

Those that do penetrate the full thickness of the gelcoat, but do not go deeply into the fiberglass or weaken the structure, can also be repaired, as follows:

1. Clean damaged area, first with mineral spirits or turpentine to remove dirt and wax. Follow with detergent and rinse. Allow to dry completely.
2. Secure a small amount of pigmented gelcoat resin matching the color of the area to be repaired. This is available from your Bertram dealer.
3. Add two drops of catalyst per cubic inch of gelcoat and mix thoroughly. The mixture will gel in 15 minutes.
4. Fill scratch with the mixture before it hardens, and round off about 1/16" to 1/18" above surrounding surface.
5. Lay a piece of wax paper or cellophane on top of the patch and press lightly to remove air. Take off wax paper after 20 minutes, and allow patch to cure overnight.
6. Sand down patch with 600 grit wet sandpaper. Finish by rubbing and buffing with regular buffing compound.

Any repairs to fiberglass that are more extensive than those described here should be made only with the help and advice of your Bertram Dealer.

PAINTING FIBERGLASS SURFACES

1. Thoroughly clean fiberglass part to be painted, removing any wax with mineral spirits, turpentine or other commercial solvents. Then wash with detergent and rinse.

2. After surface is dry, sand lightly with garnet paper, fine oxide paper or #220 sandpaper. Wipe clean of all dust.

3. Apply two thin coats of primer as recommended by marine paint manufacturer.

4. Apply regular coat of epoxy paint of good quality as manufacturer directs.

While the fiberglass bottom of your Bertram is inherently anti-fouling, you may find your cruising waters make an anti-fouling paint application worthwhile. Follow the above directions (and those of the manufacturer) in applying such a paint to your hull.

CARE OF AWL- GRIP PAINTED SURFACES

Your 58' Convertible has an aluminum deck and superstructure painted with special Bertram White Awl-Grip polyurethane paint with the same gloss factor as the gelcoat. Maintenance is much the same as the fiberglass hull. By cleaning with liquid soap and fresh water for normal wash down procedure caution is advised against using any abrasive cleaners on painted surfaces.

PAINTING ALUMINUM SURFACES

Sand damaged area with 400 wet or dry sandpaper, very wet. Find natural cutoff point such as edge or corner if possible, mask off, and spray entire area. If you cannot do this, feather out sanding 6" all around repair area. Spray 3 or 4 light crosshatch coats with a small spray gun. Keep spray pattern inside the sanded area. When paint has cured compound out the overspray.

If damage goes below paint finish it will be necessary to prime the area with a white compatible primer.

NOTE: When any hardware or items that require holes drilled in the aluminum deck or superstructure of the 585, extreme care must be used in bedding it. Sufficient bedding must be used to prevent moisture entering the base material under the urethane finish as it will eventually create a blistering, lifting effect of the base material and paint around the hardware or item.

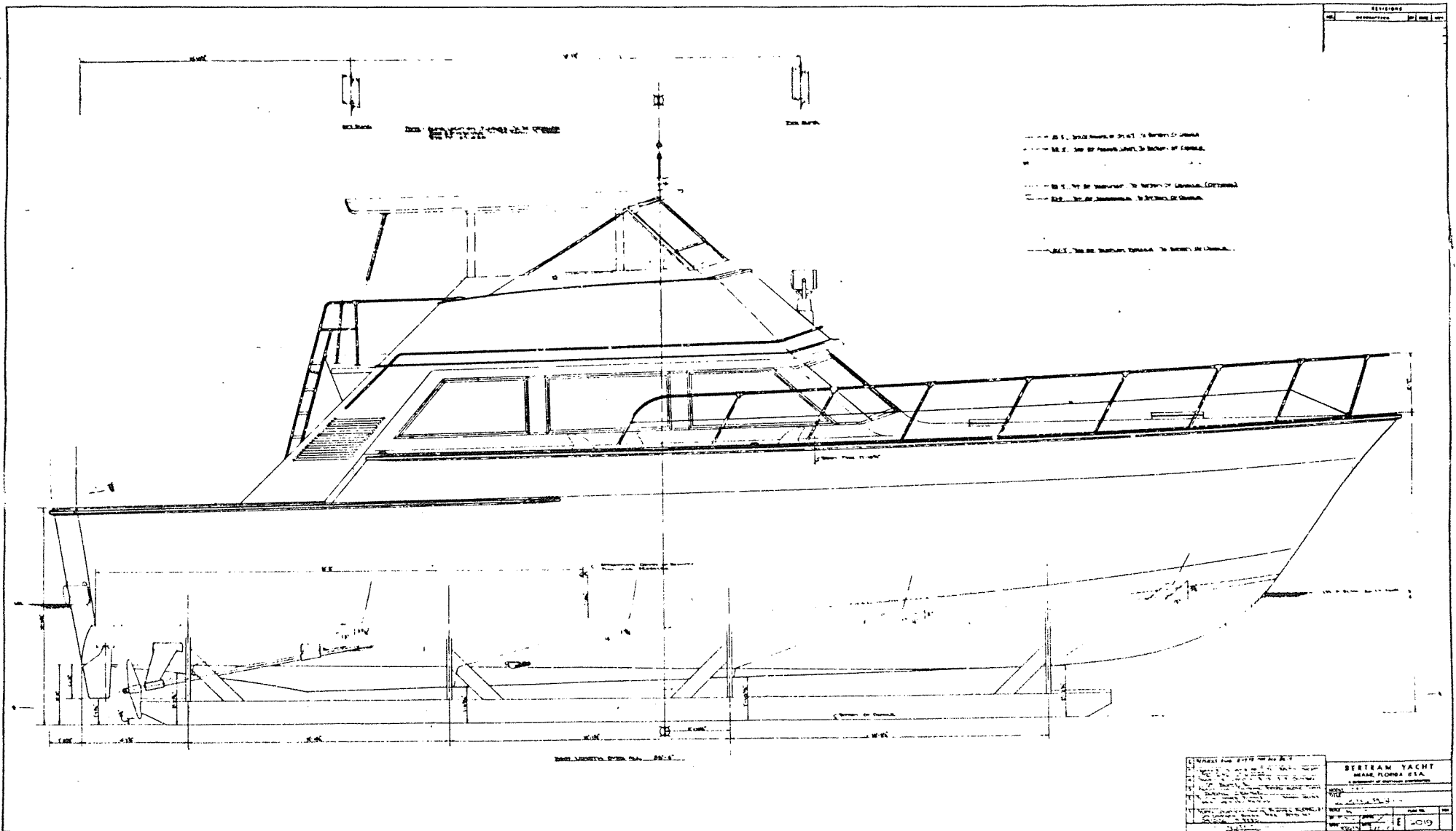

| REVISIONS | |
|-----------|-------------|
| NO. | DESCRIPTION |
| | |
| | |

ALL DIMENSIONS TO BE GIVEN IN FEET AND INCHES
 UNLESS OTHERWISE SPECIFIED
 ALL DIMENSIONS TO BE GIVEN IN METERS AND MILLIMETERS
 UNLESS OTHERWISE SPECIFIED
 ALL DIMENSIONS TO BE GIVEN IN METERS AND MILLIMETERS
 UNLESS OTHERWISE SPECIFIED

| | |
|---|---------------|
| BERTRAM YACHT MIAMI, FLORIDA, U.S.A. DIVISION OF BERTRAM YACHT DESIGNERS | |
| PROJECT NO. 1019 SHEET NO. 1019-1 | DATE 10/19/69 |

BERTRAM 58

CONVERTIBLE

ELECTRICAL SYSTEMS

WIRING DIAGRAMS

MODEL 585 CONVERTIBLE
WIRING DIAGRAM ALTERATION RECORD

| LTR. | DESCRIPTION | PAGES | BY | DATE | APVI |
|-------|-------------------------|-------|-----|---------|------|
| Orig. | Released for production | all | LCH | 3/23/77 | |

MODEL 585 CONVERTIBLE

WIRING DIAGRAMS-INDEX

ELECTRICAL WIRING DIAGRAMS

PAGE

| | |
|--|----------|
| Alteration Record | WD1 |
| Index | WD 2,3 |
| Abbreviations & Symbols | WD 4,5 |
| <u>32 VOLT DC</u> | |
| Basic Diagram - Battery, Starting, Charging | 32 DC-1 |
| 32 VDC Distribution Panel - Flow Diagrams | 32 DC-2 |
| 32 VDC Power Panel Wiring Diagram, Back View | 32 DC-3 |
| TB/D-1 Engine Room Sump Pump, Engine Room Lights, Gen. Room Switch | 32 DC-4 |
| TB/D-2 Port and Stbd. lights, Fresh Water Tank, Gauge | 32 DC-5 |
| 32V Panel lights | 32 DC-6 |
| Air Horn, Fish Box, Fwd. showers | 32 DC-7 |
| Searchlight | 32 DC-8 |
| Toilet System Block Diagram | 32 DC-9 |
| Lectra/San Treatment Power Supply | 32 DC-9A |
| Lectra/San & Toilet Wiring Diagram | 32 DC-10 |
| <u>CONTROL STATIONS</u> | |
| Bridge Console Panel & Switches | 32 DC-11 |
| Aft Bridge Station (optional) | 32 DC-12 |
| Rudder Indicator | 32 DC-13 |
| Terminal Block Arrangement | 32 DC-14 |
| TB/C-1 Aft Bilge Pump, Port Blower | 32 DC-15 |
| TB/C-2 Stbd. Blower, Fwd. Bilge Pump | 32 DC-16 |
| TB/C-3 Navigation Light | 32 DC-17 |
| TB/C-4 Automatic Blower | 32 DC-18 |
| Safety Alarm System, Block Diagram | 32 DC-19 |

| | |
|-------------------------------------|----------|
| Safety Alarm System, Wiring Diagram | 32 DC-20 |
| TB/C-6 Trim Tabs | 32 DC-21 |

ENGINES

| | |
|------------------------|----------|
| Engine Terminal Blocks | 32 DC-22 |
| Engine Looms | 32 DC-23 |

12 VOLT D.C.

| | |
|--|---------|
| 12 VDC Electronic Distribution Panel, Flow Diagram | 12 DC-1 |
| Single Generator Control & Wiring Diagram | 12 DC-2 |
| Dual Generator Controls and Wiring Diagram | 12 DC-3 |
| Docking Lights, Fwd. and Transom | 12 DC-4 |
| Electronic Distribution Panel Lighting | 12 DC-5 |

120/240 VOLT AC

| | |
|---|---------|
| 120/240 Distribution System, Single Generator - Block Diagram | AC - 1 |
| 120/240 Distribution System, Dual Generator - Block Diagram | AC - 2 |
| Shore Cords and Inlets | AC - 3 |
| 120/240 Shore Power Wiring Diagram | AC - 4 |
| 120 VAC Shore Power Wiring Diagram | AC - 5 |
| Single Generator Power Wiring Diagram | AC - 6 |
| Dual Generator Power Wiring Diagram | AC - 7 |
| Air Conditioning, Fwd. Cabins Block Diagram | AC - 8 |
| Air Conditioning, Fwd. cabins Wiring Diagram | AC - 9 |
| Air Conditioning, Salon, Block Diagram | AC - 10 |
| Air Conditioning, Salon, Wiring Diagram | AC - 11 |
| Stereo System Speaker Circuits | AC - 12 |

ABBREVIATIONS & SYMBOLS

| | |
|----------|--|
| A | Ampere, Automatic |
| Ⓐ | Amber pilot lights |
| Ⓐ Ⓑ Ⓒ | etc. Terminals for engine looms, see Engine and Alarm |
| A.C. | Alternating Current |
| AMM. | Ammeter |
| AMP. | Ampere |
| B, BLK. | Black |
| BLU | Blue |
| BR | Brown |
| C.B. | Circuit Breaker |
| EL-P | Engine Loom, Port |
| EL-S | Engine Loom, Stbd. |
| G, GRN. | Green |
| KW | Kilowatt |
| M | Manual |
| MOM. | Momentary |
| N.C. | Normally Closed |
| N.O. | Normally Open |
| OPT. | Optional Equipment |
| P | Port |
| R | Red |
| Ⓔ Ⓡ | Red Pilot Light |
| S, STBD | Starboard |
| SW | Switch |

| | |
|---------|---------------------------|
| TB/C | Terminal Block , Console |
| TB/D-A | " " , Alarm |
| TB/D-P | " " , Distribution, Port |
| TB/D-S | " " , Distribution, Stbd. |
| TB/E-P | " " , Engine, Port |
| TB/E-S | " " , " , Stbd. |
| V | Volts |
| V.A.C. | " , Alternating Current |
| V.D.C. | " , Direct " |
| W | Watts |
| W, WHT. | White |
| Y, YEL. | Yellow |

| | |
|------|---------------------------|
| 14/2 | Duplex Wire, #14, 2-Cond. |
| 10/2 | Duplex Wire, #10, 2-Cond. |
| 14/3 | Triplex " , #14, 3-Cond. |
| 10/3 | Triplex " , #10, 3-Cond. |
| 6/3 | Triplex " , #6 , 3-Cond. |



Ohm



Resister



Fuse



Terminal



Ground Bus



Ground, Case or Bonding

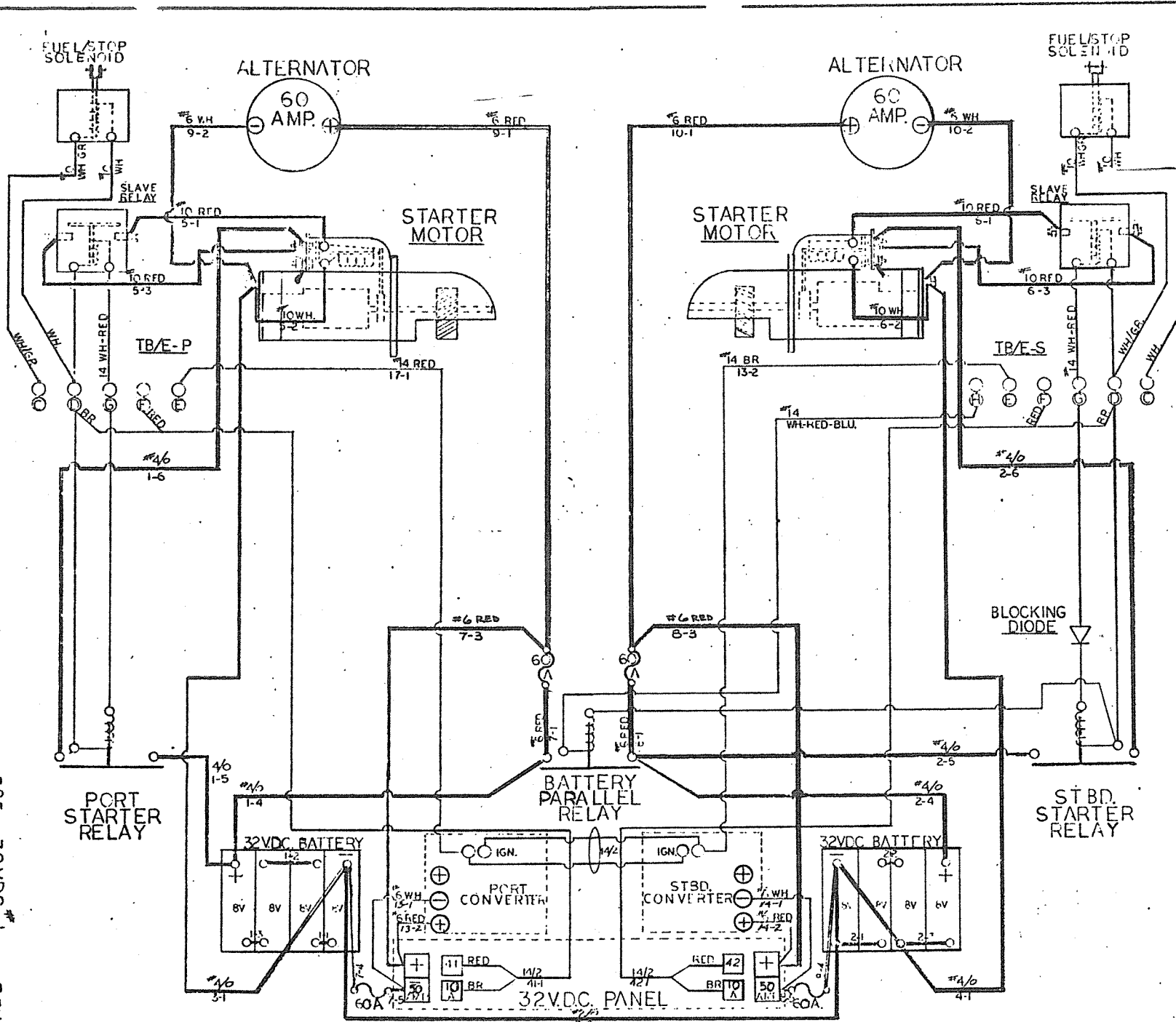

| NOTES | | | | |
|-------|--|------|---------|-------------|
| LT | DESCR. | BY | DATE | APP |
| A | 1. ADDED CONVERTER - IGNITION WIRING 2. OMITTED AMMETERS & SHUNTS 3. ALL BATTERY CABLES TO BE #10 | A.C. | 12/1/13 | [Signature] |

- NOTES:
- IMPORTANT: 32VOLT SYSTEM IS ISOLATED (UNGROUNDING)
 - ENGINE TERMINAL BLOCKS DIAGRAM DOES NOT SHOW ALL TERMINALS NOR ARE THEY IN SEQUENCE

| | | | | |
|--|--|----------|--------|---|
| BERTRAM YACHT MIAMI, FLORIDA, U.S.A. A SUBSIDIARY OF WHITTAKER CORPORATION | | | | |
| MODEL | 5445 | | | |
| TITLE | BASIC WIRING DIAGRAM BATTERY STARTING CIRCUIT | | | |
| SCALE | 1:1 | PLAN NO. | C 5445 | |
| BY | APPROV. | DATE | | |
| | | | | A |

585 32VDC #1 REV. A

DRAWING NO. 28858

PORT ENGINE

STBD. ENGINE

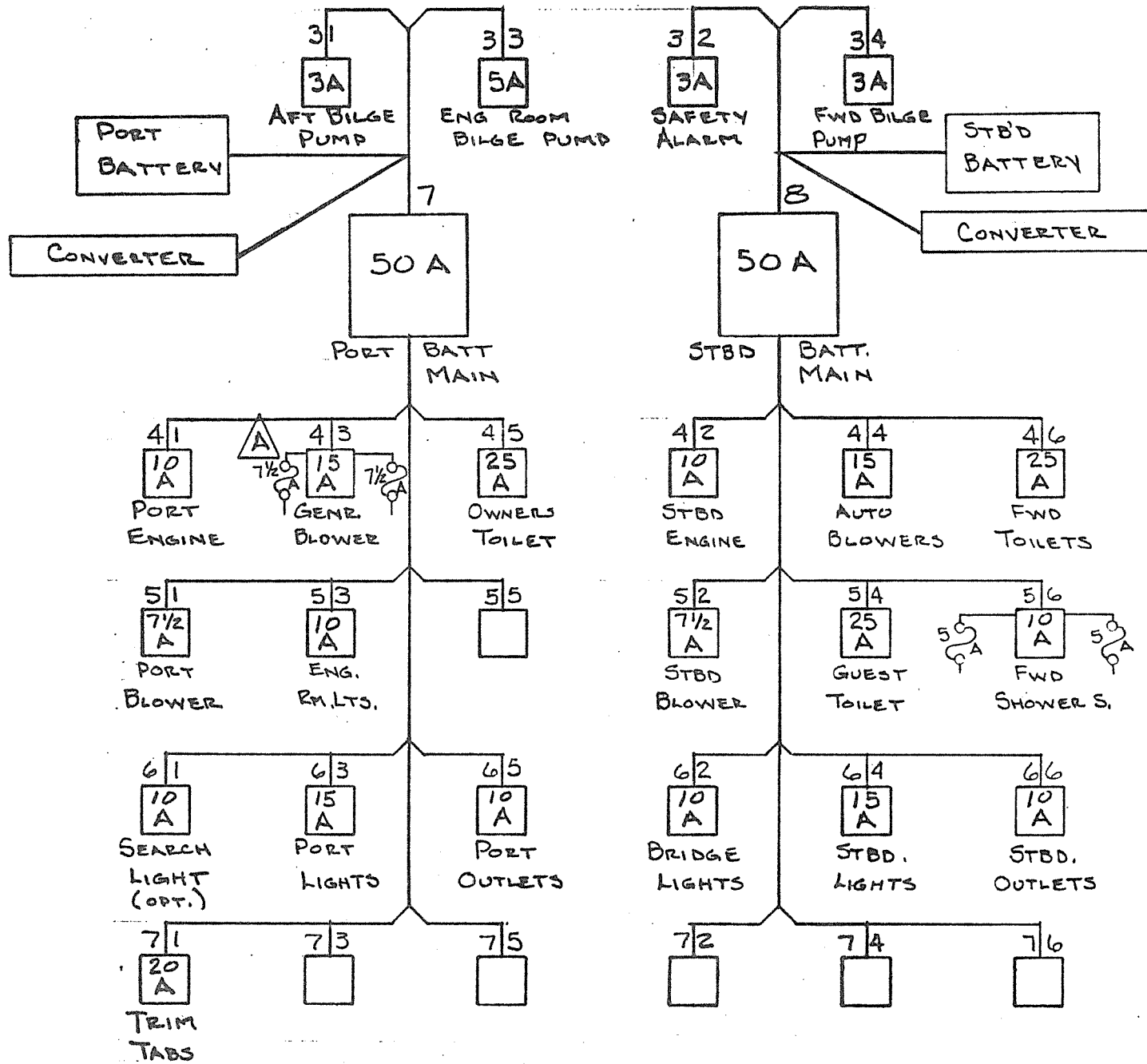

▲ DUAL GENR. OPT. IS SHOWN. SINGLE GENR. STD. IS ONE 7 1/2 AMP. C.B.

32 V.D.C. DISTRIBUTION PANEL

FLOW DIAGRAM

585 32DC-2

REV. A

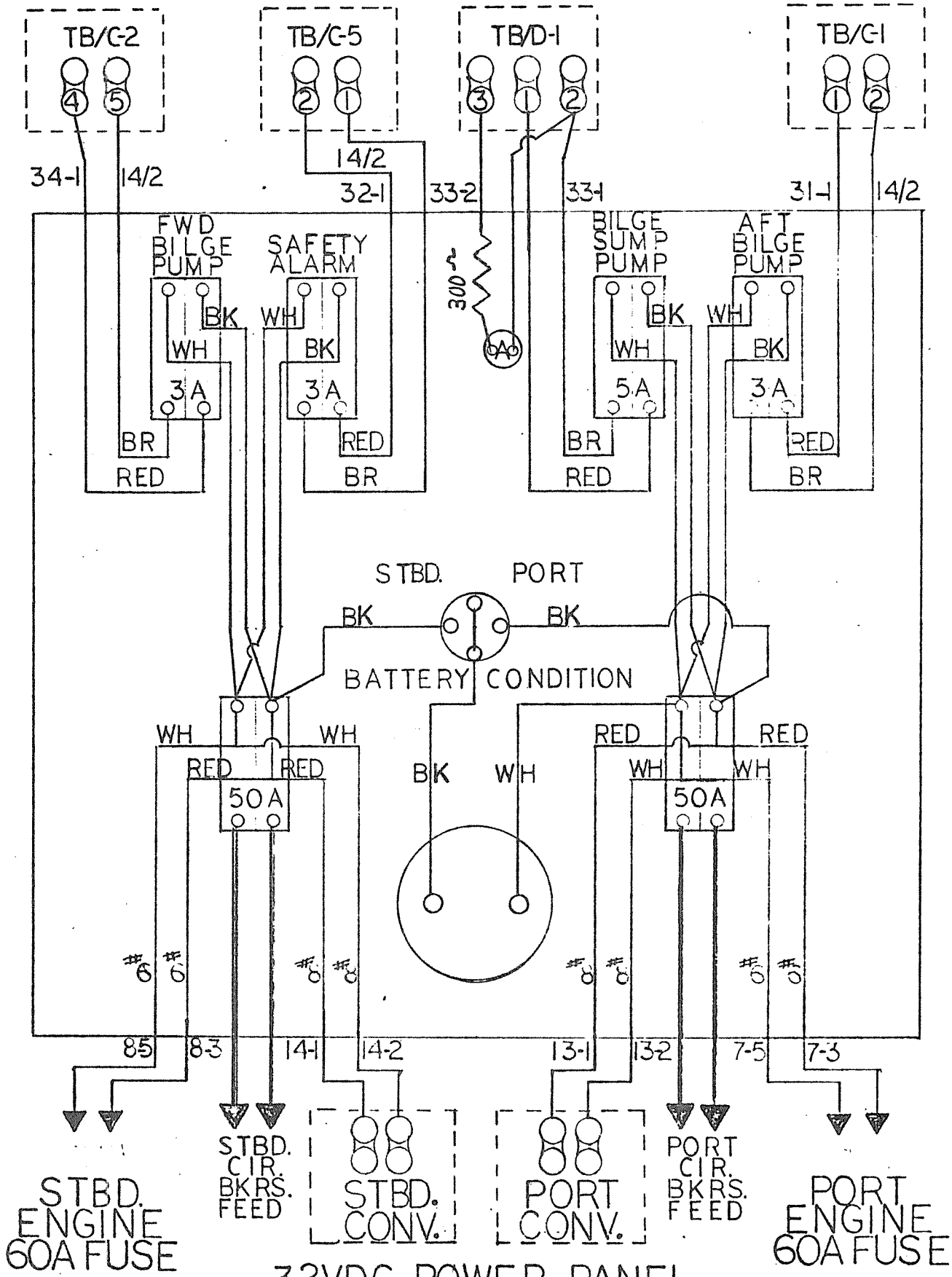

32VDC POWER PANEL
WIRING DIAGRAM
(BACK VIEW)

REV. A

585 32DC 3 #

ENGINE ROOM
SUMP PUMP

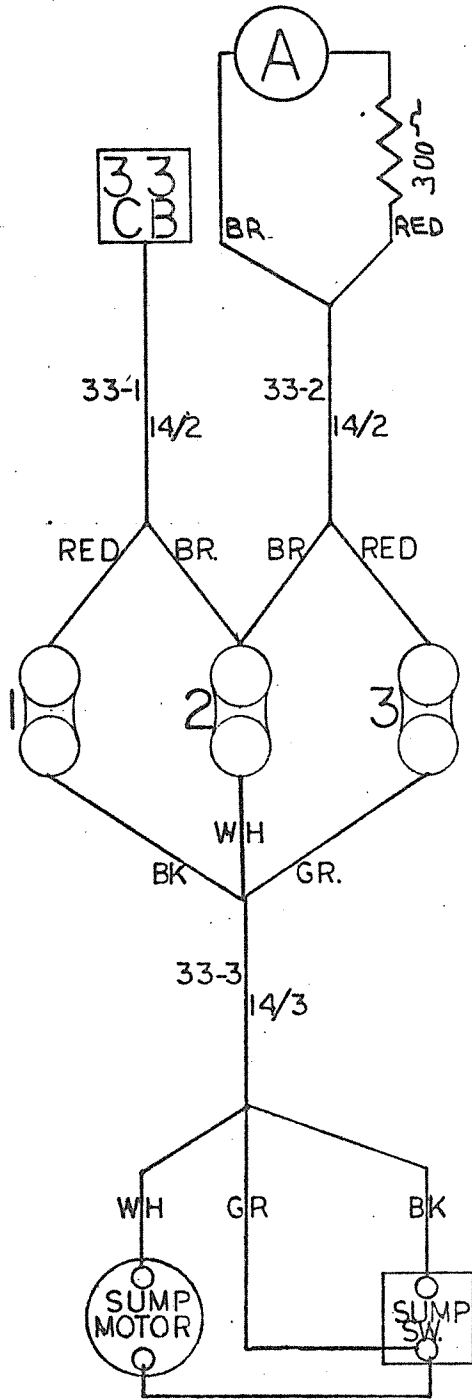

ENGINE ROOM
LIGHTS

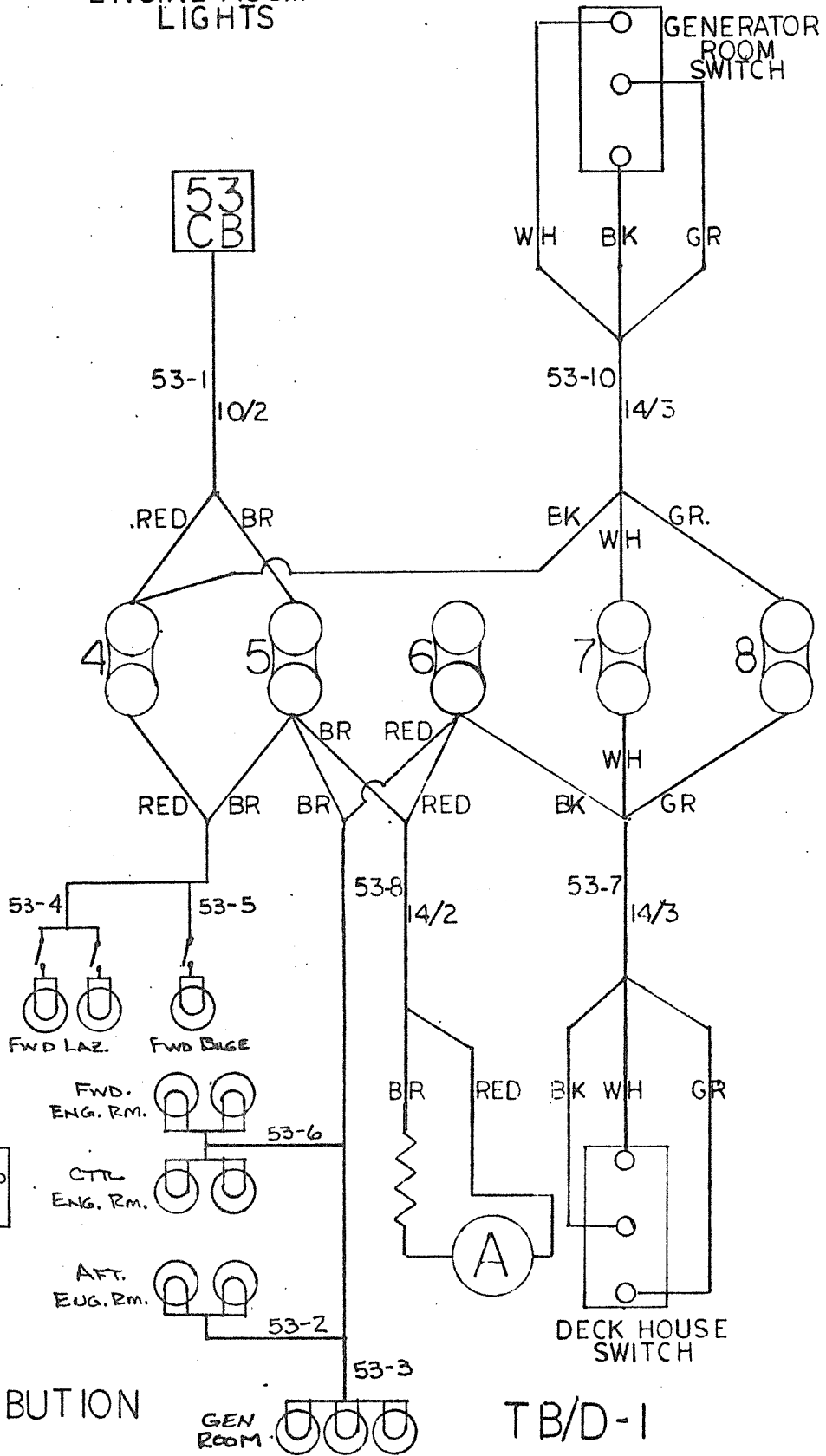

32VDC DISTRIBUTION
BOX

GEN ROOM

TB/D-1

585

32DC #4 REV. A

PORT STBD
LIGHTS LIGHTS

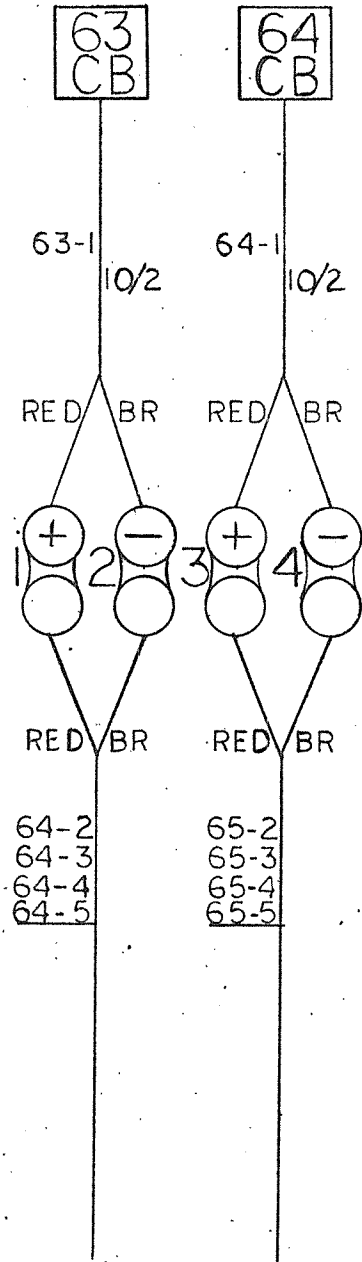

32VDC DISTRIBUTION
BOX

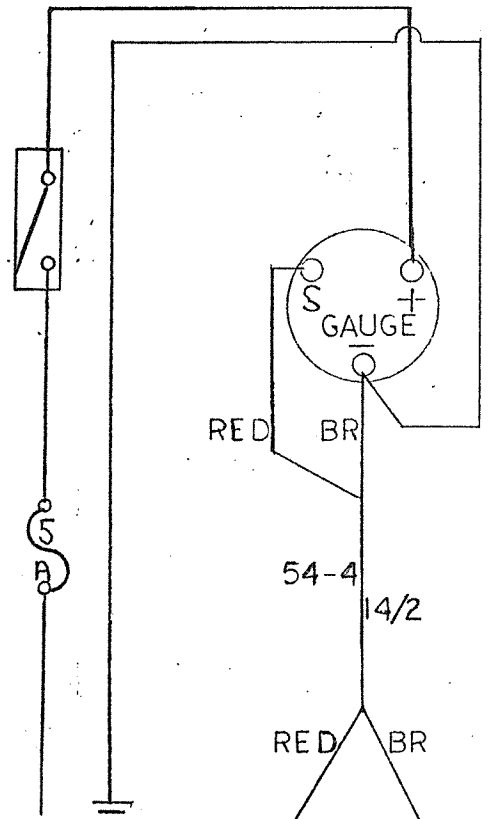

SEE DRAWING
12VDC #2

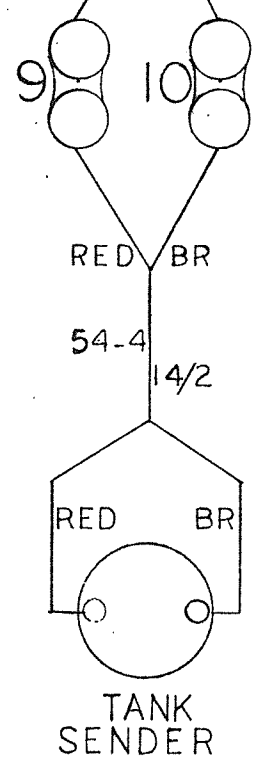

TB/D-2

585

32VDC #5

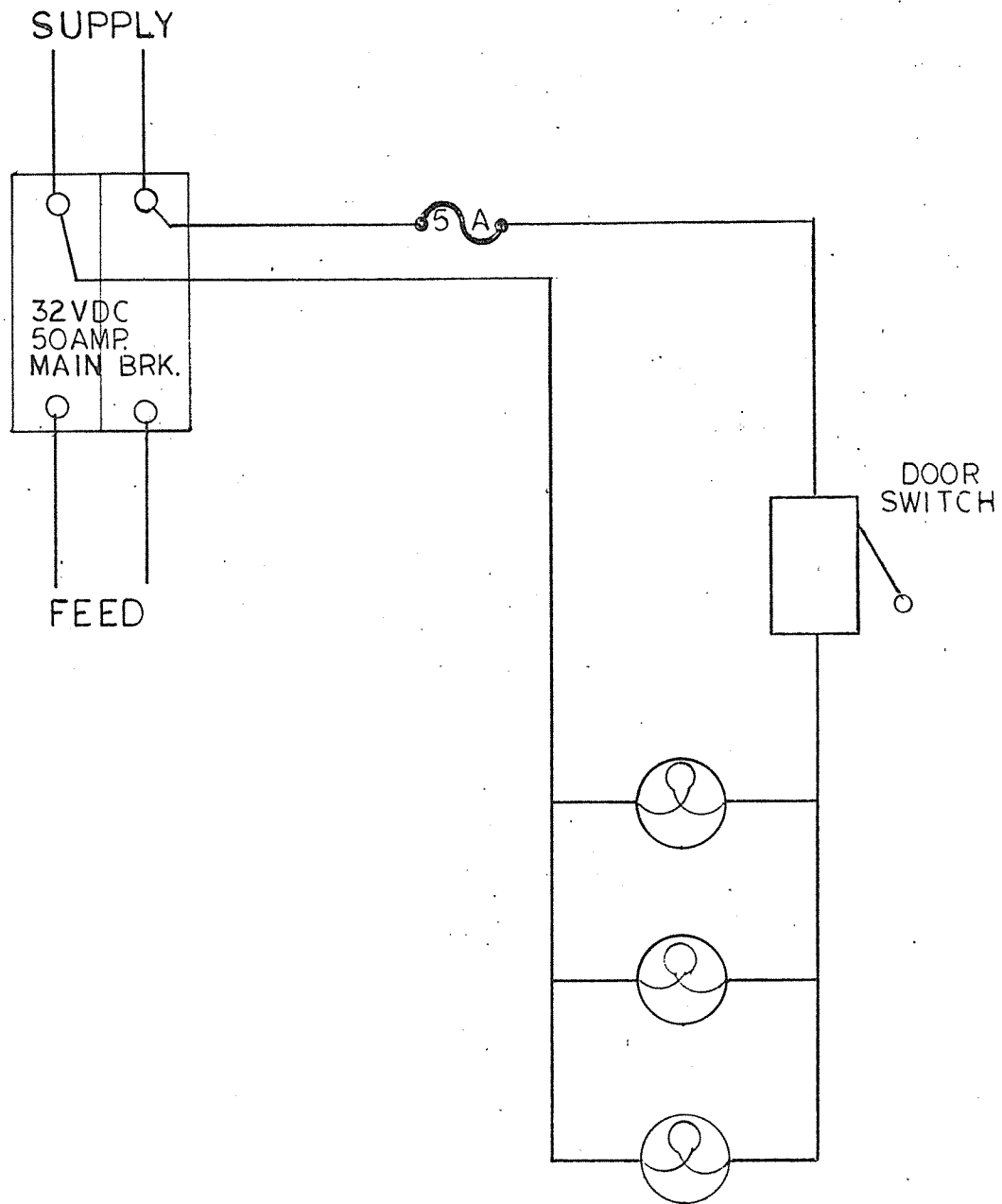

32V PANEL LIGHTS

585 32 DC #6

AIR HORN

To TB/E PORT

(F) (D)

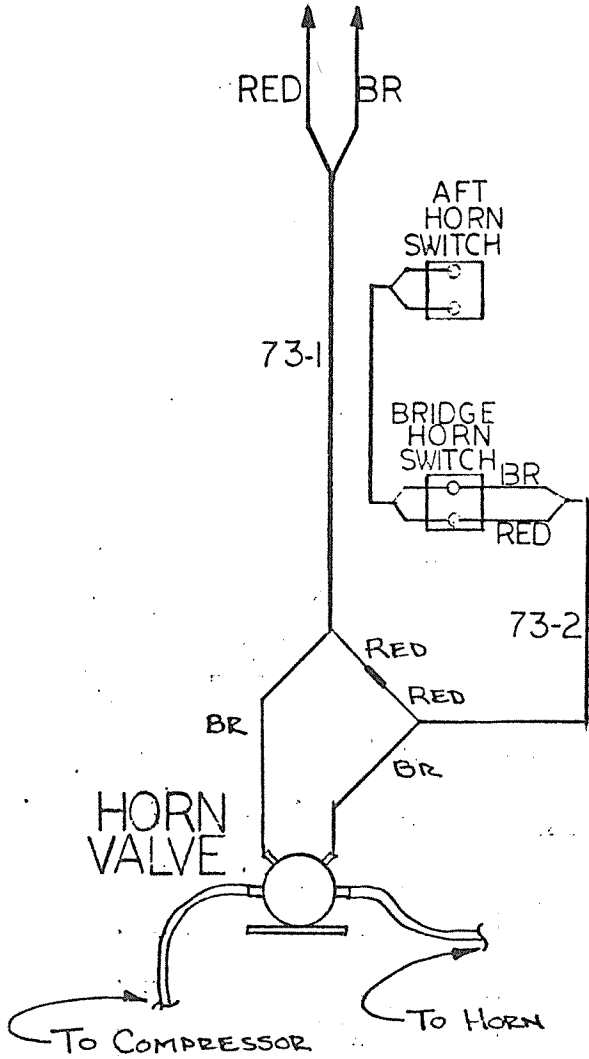

FWD. SHOWERS

56
C.B.

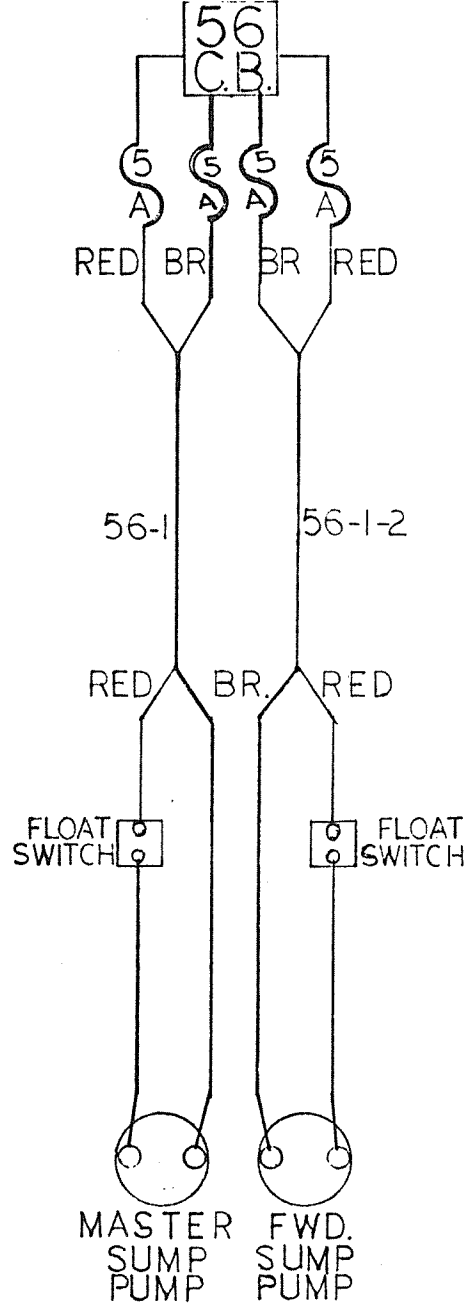

SEARCHLIGHT (RAY-LINE) (4102C-0002)

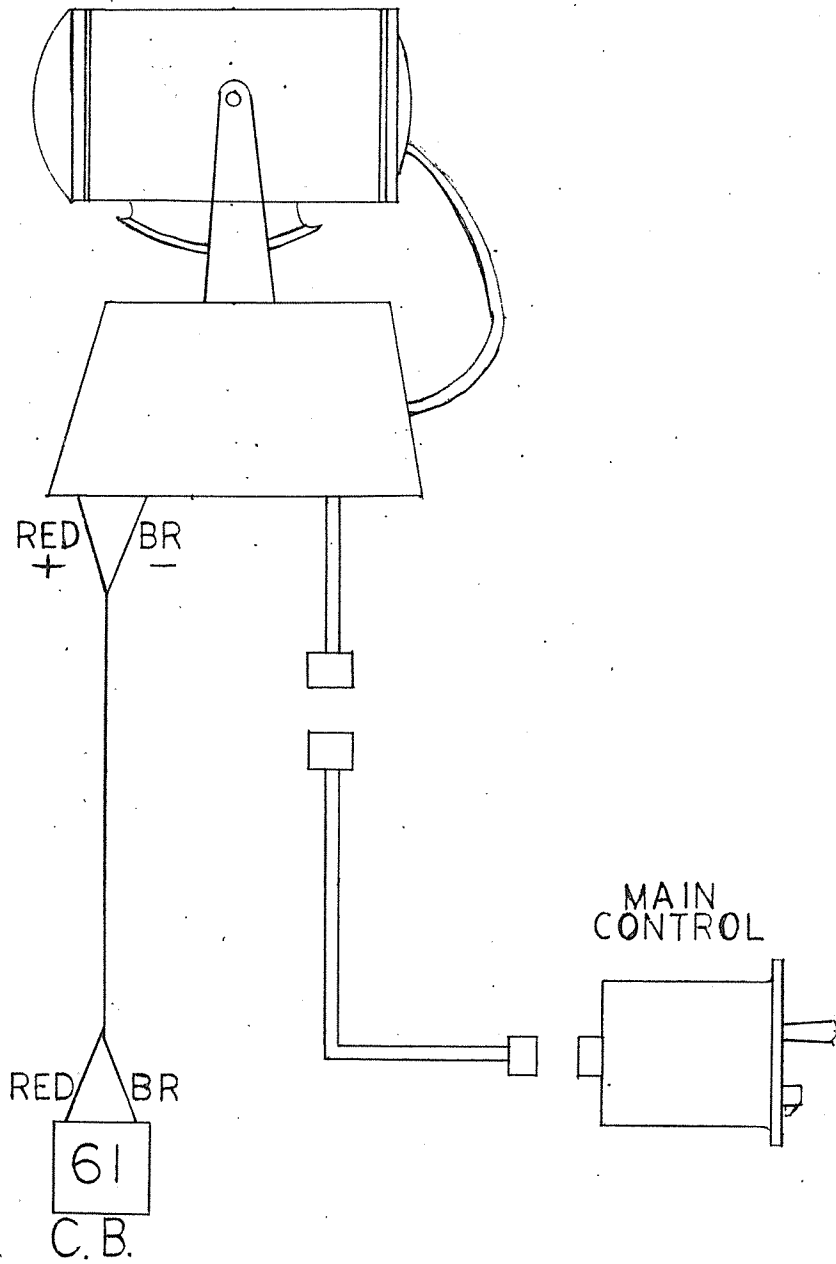

585

32DC[#]8

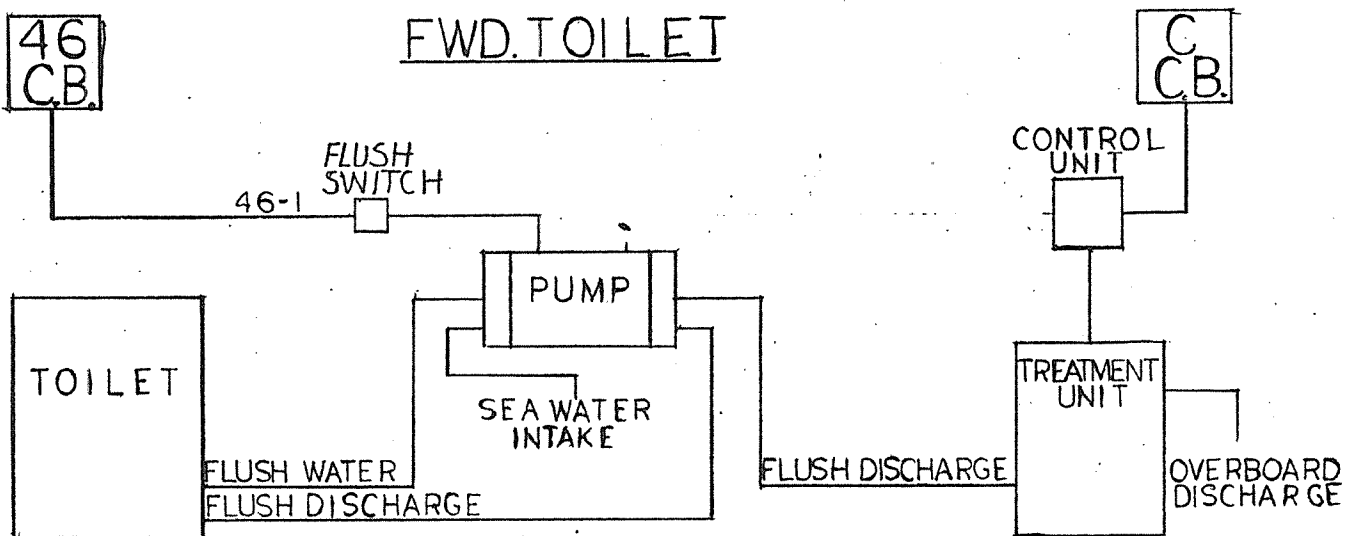
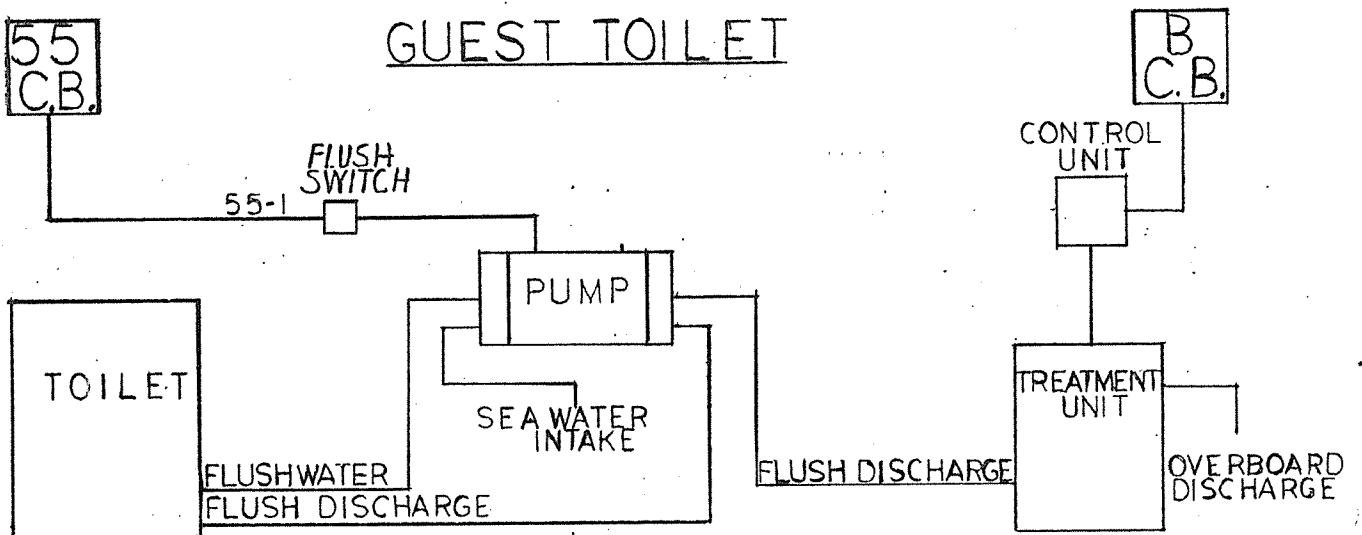
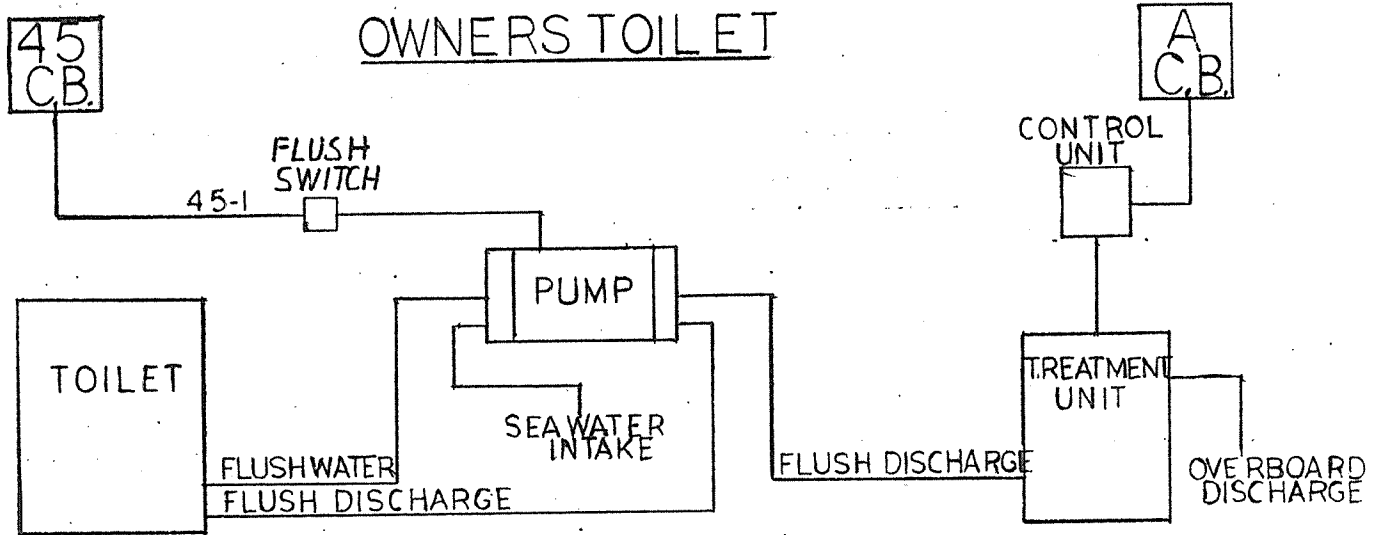

TOILET SYSTEM
BLOCK DIAGRAM

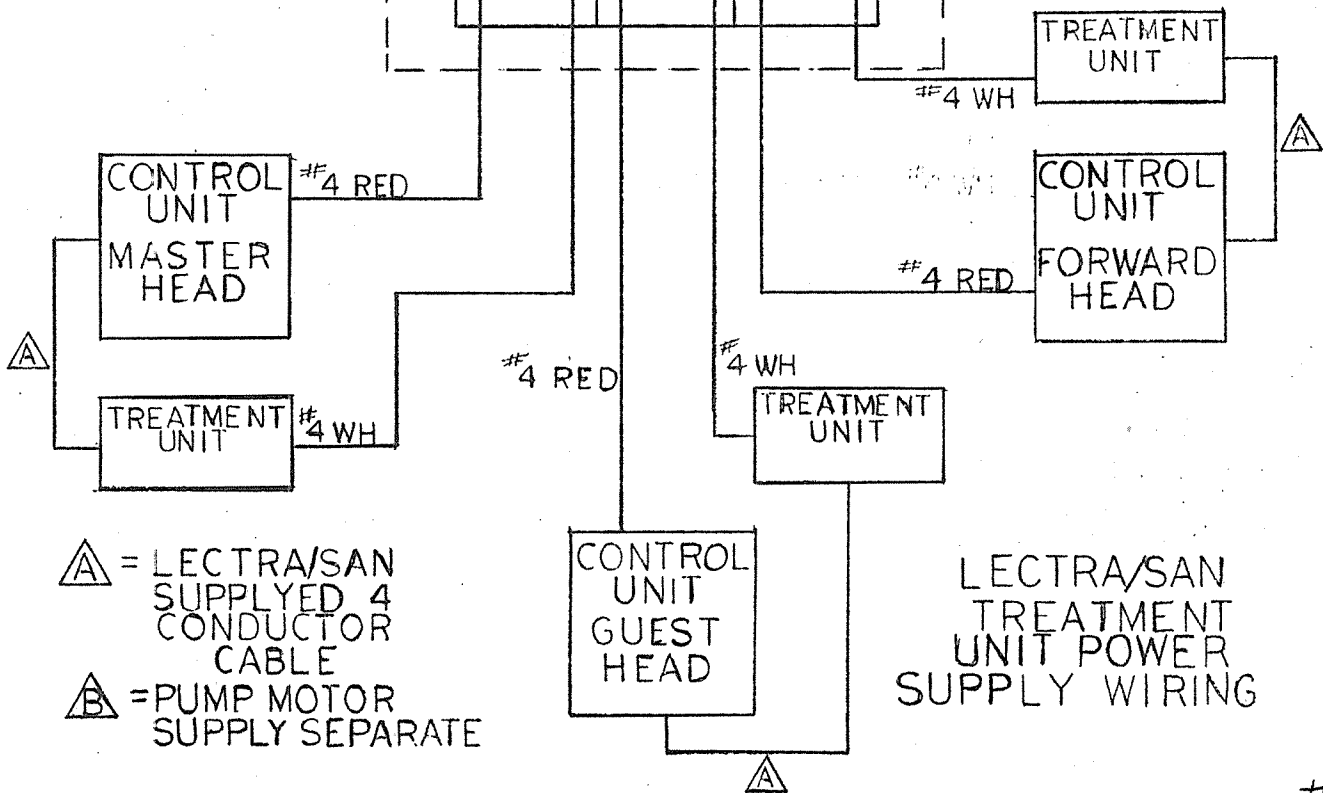
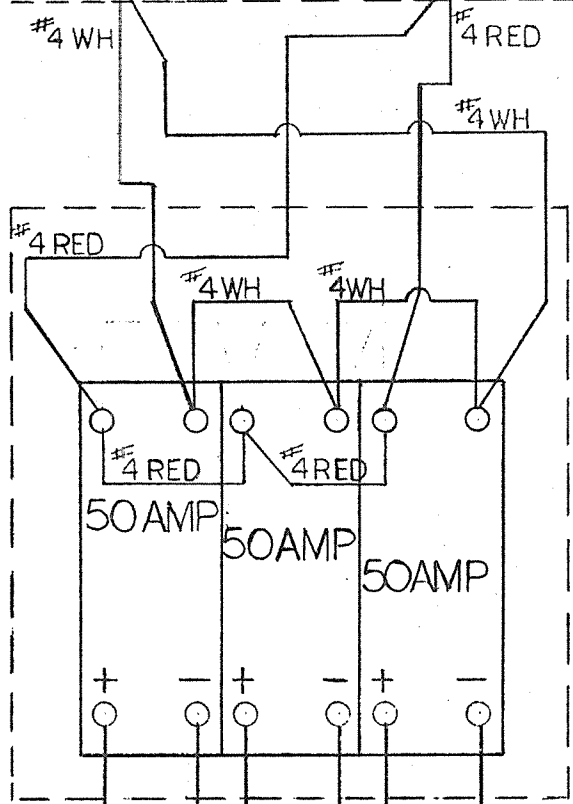
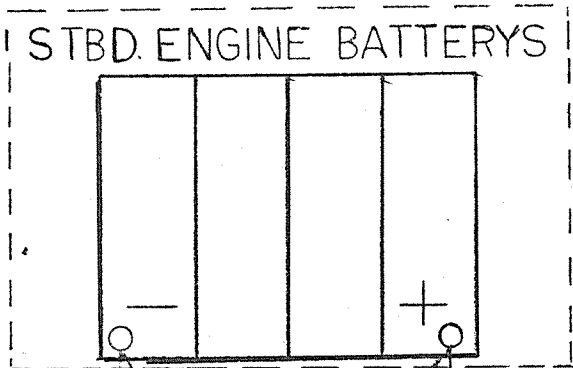

585 32VDC # 9A

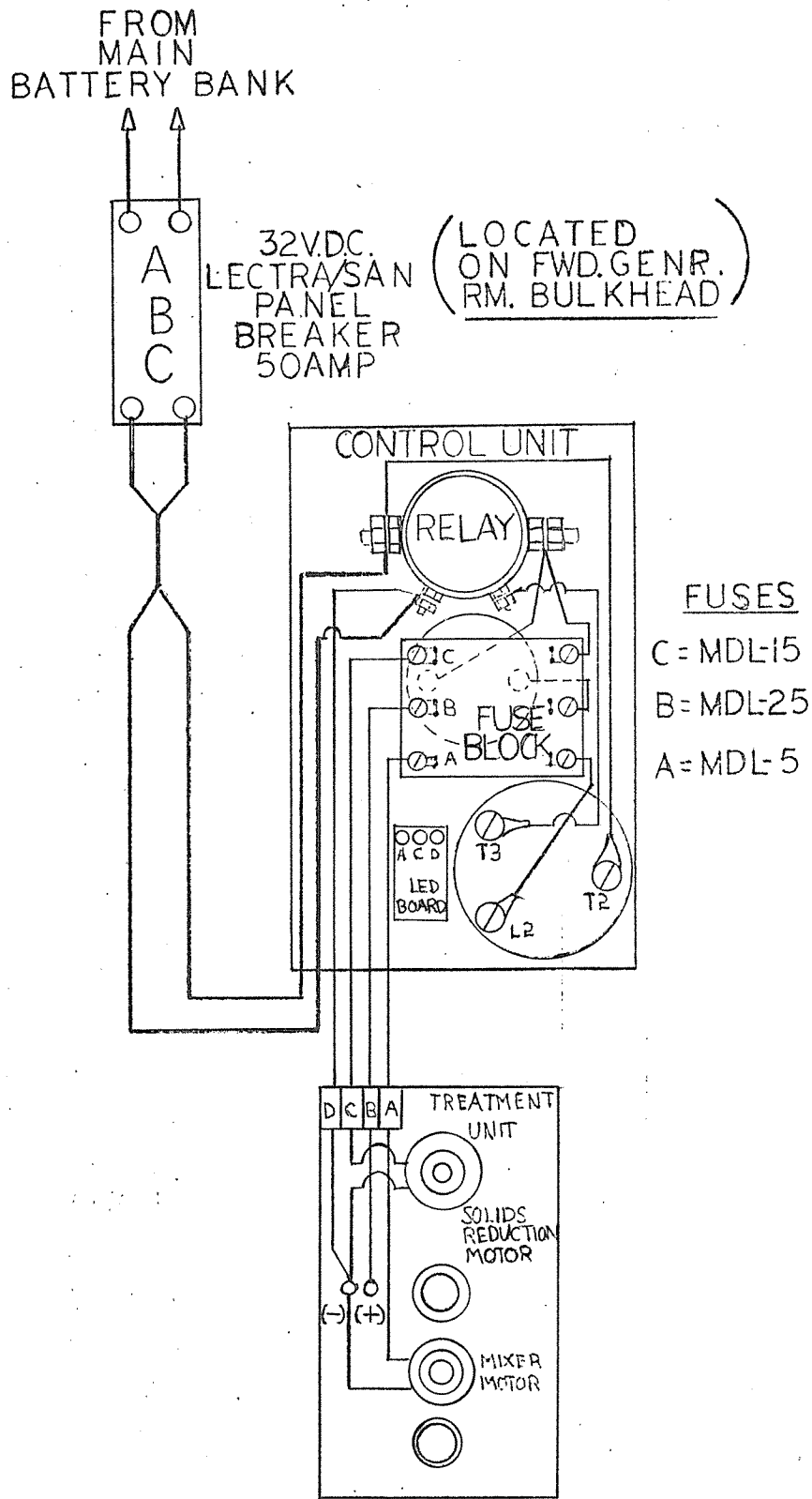
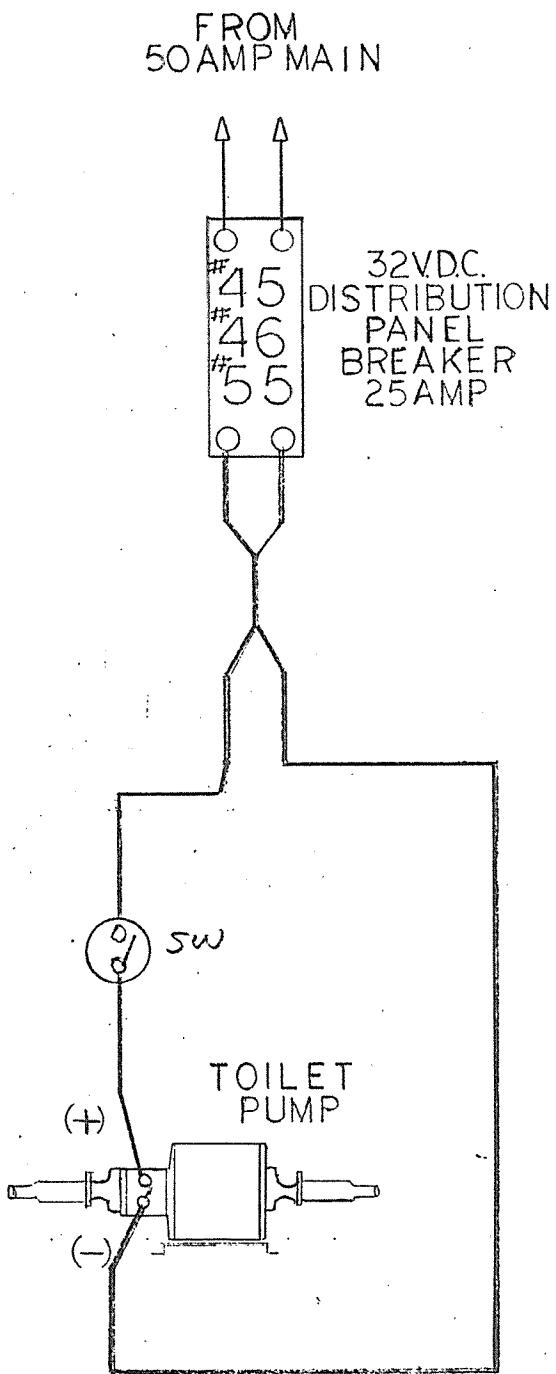

LECTRA/SAN TOILET WIRING DIAGRAM

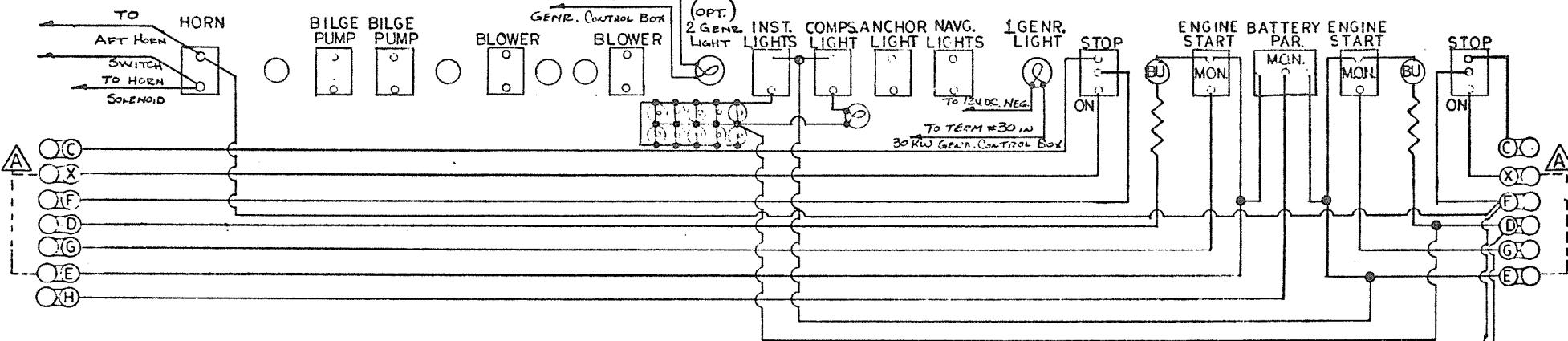
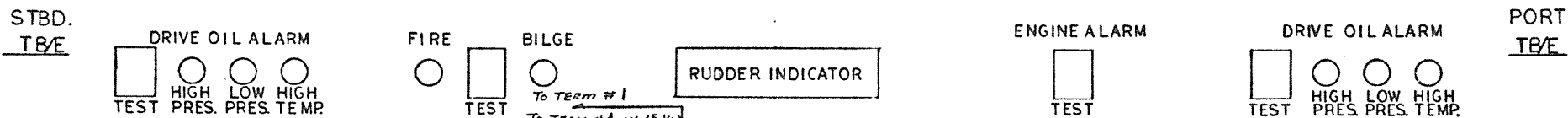
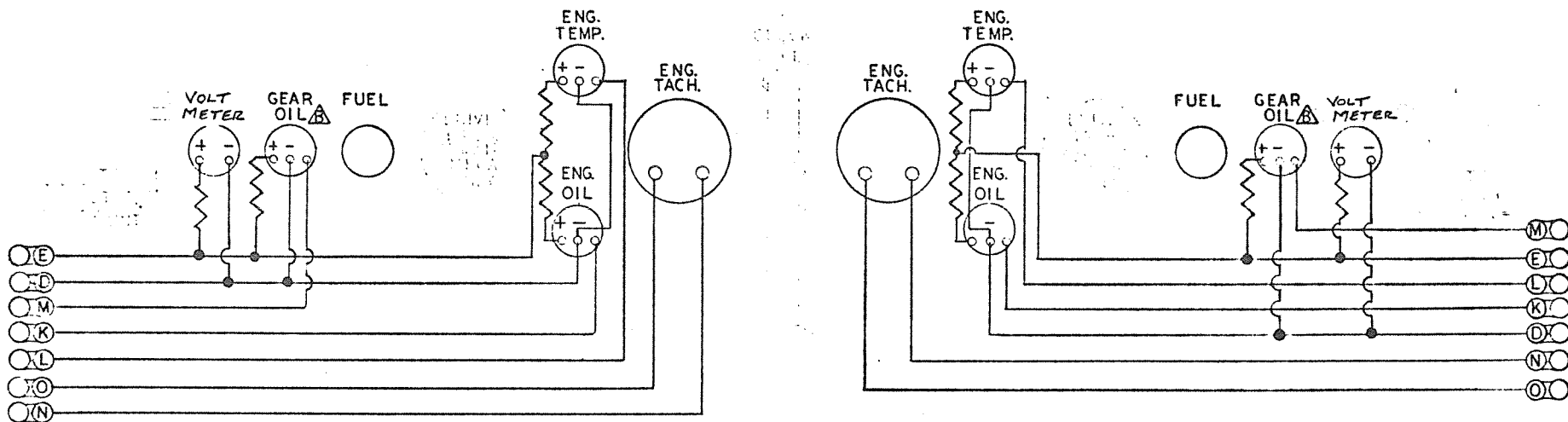

△ = X & F JUMPER USED ONLY ON SINGLE STATION

BRIDGE CONSOLE (BOTTOM VIEW)

CHART LIGHT

REV. A

585 32DC #11

AFT BRIDGE STATION BOTTOM VIEW

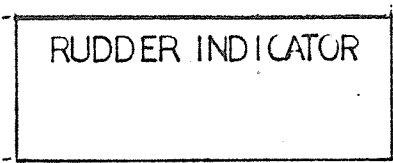
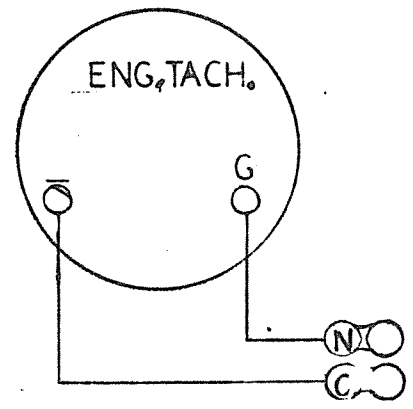
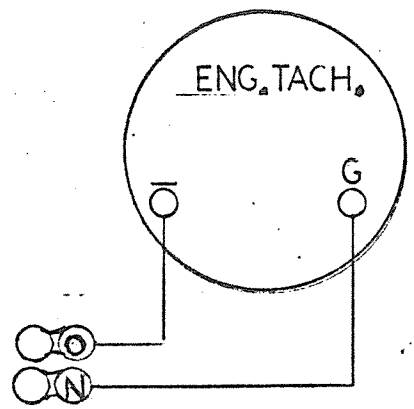

REV. A

585 32DC #12

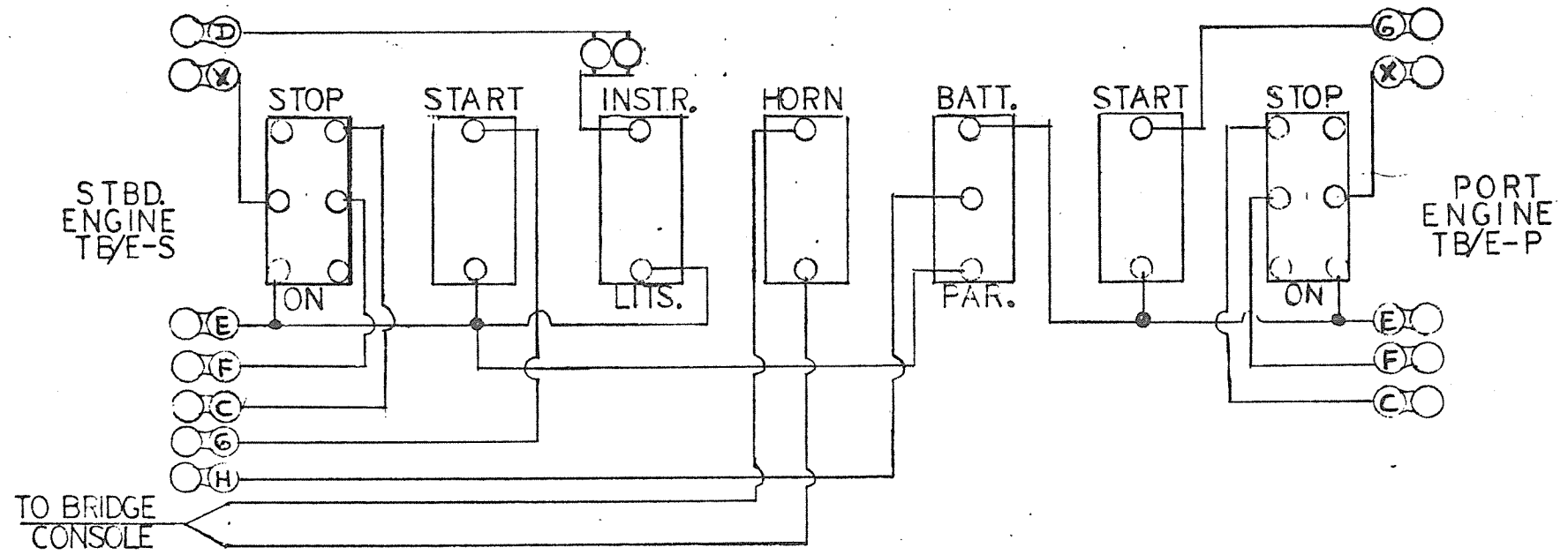

RUDDER INDICATOR

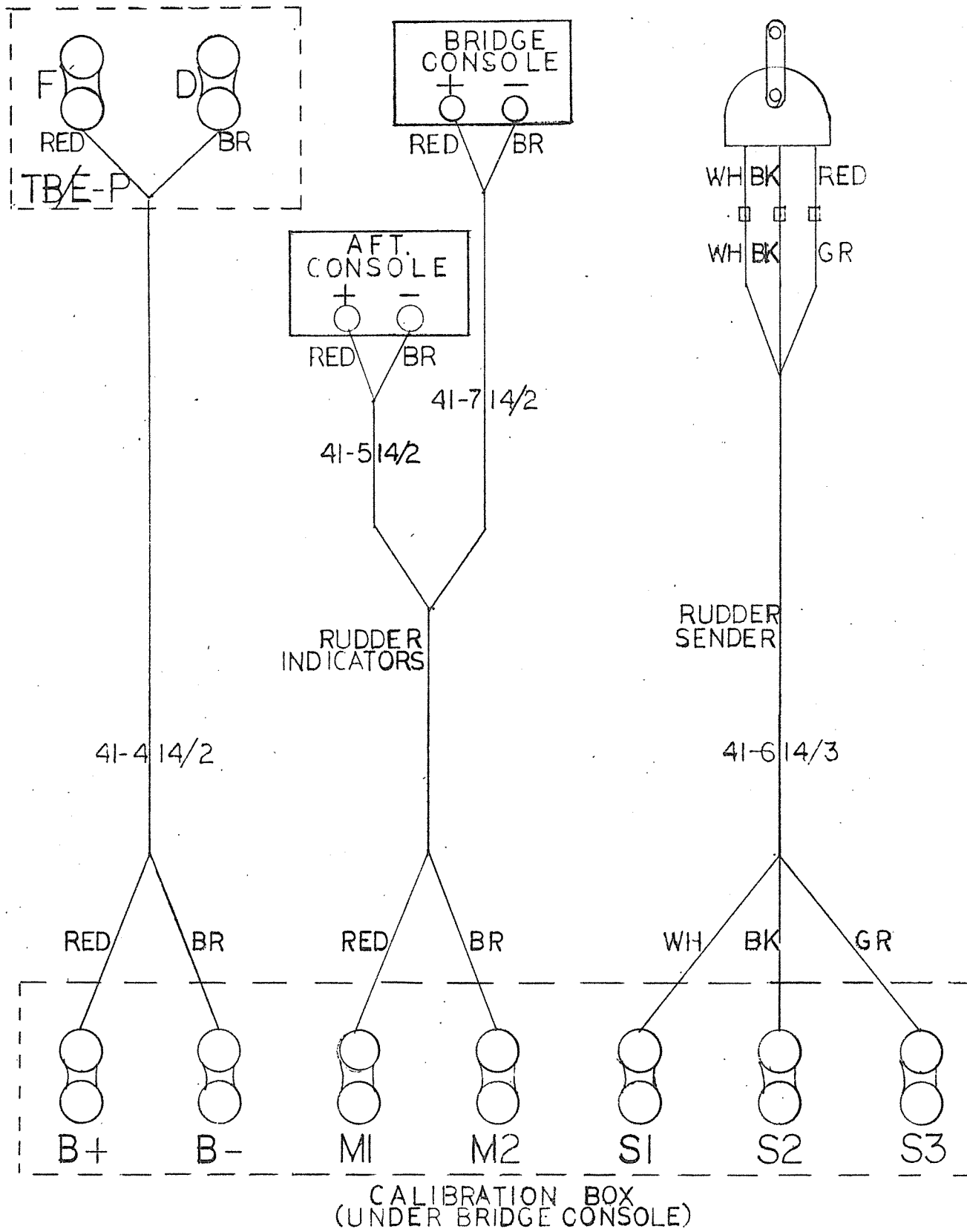

TB/E-P

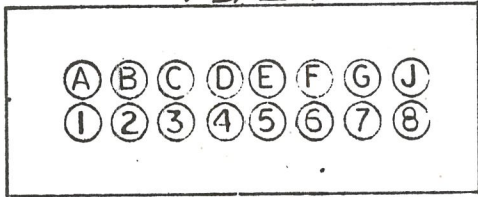

TB/E-S

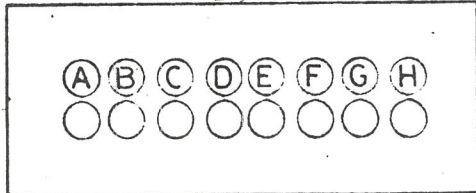

TB/C-1

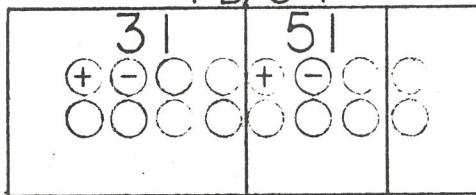

TB/C-3

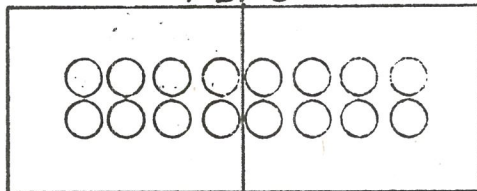

TB/C-5

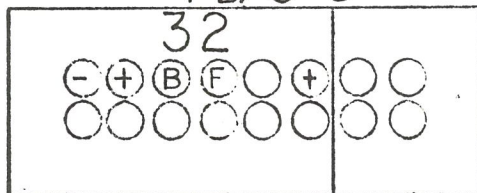

AUTO BLOWER SOL.



TB/E-P

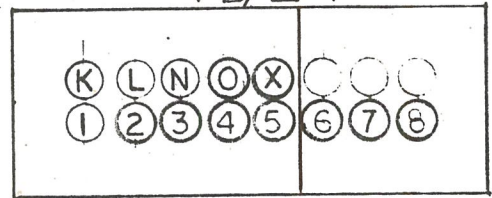

TB/E-S

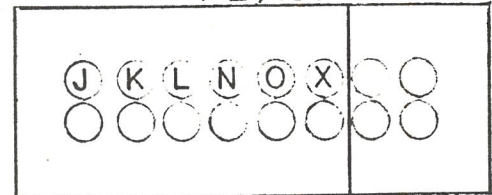

TB/C-2

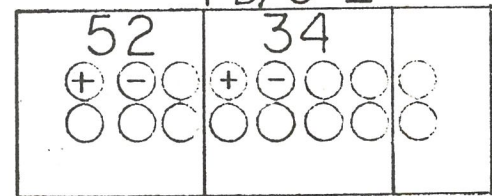

TB/C-4

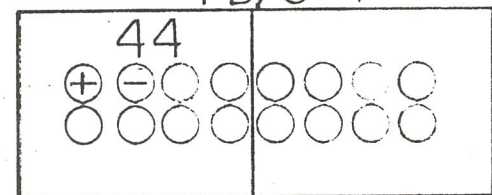

TB/C-6

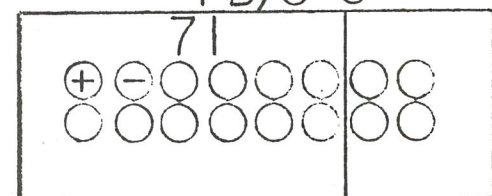

RUDDER CALIBRATION BOX

TERMINAL BLOCK
ARRANGEMENT
(UNDER BRIDGE CONSOLE)

AFT BILGE PUMP

PORT BLOWER

BRIDGE CONSOLE

BRIDGE CONSOLE

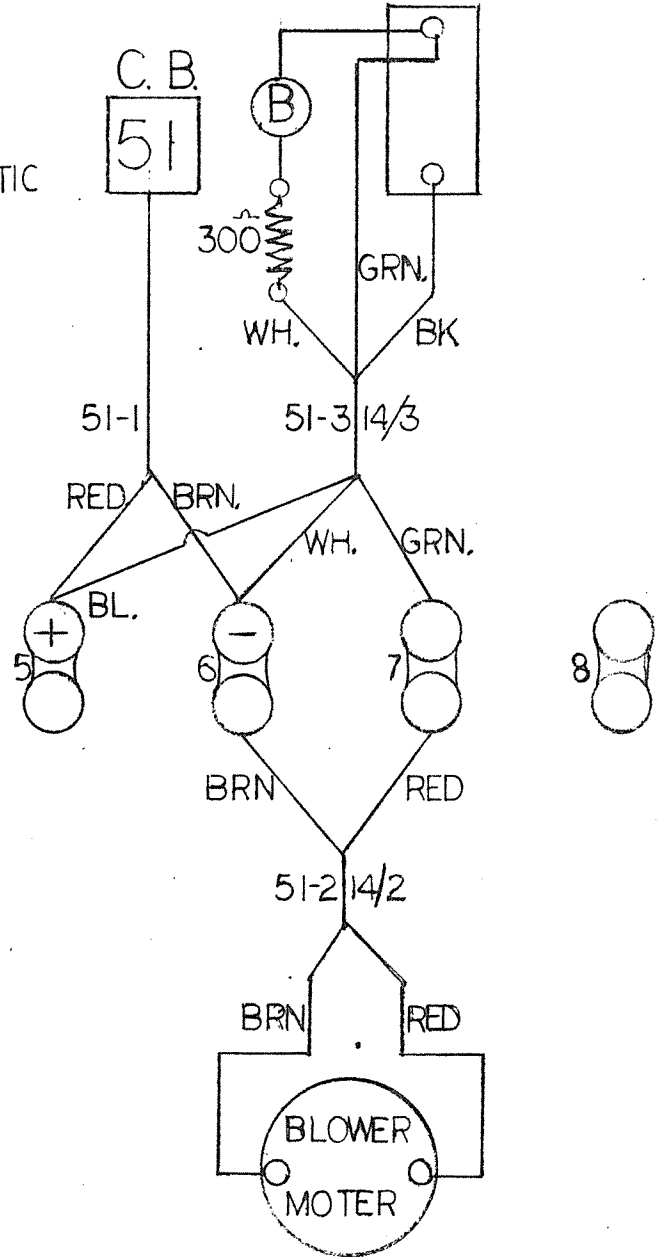
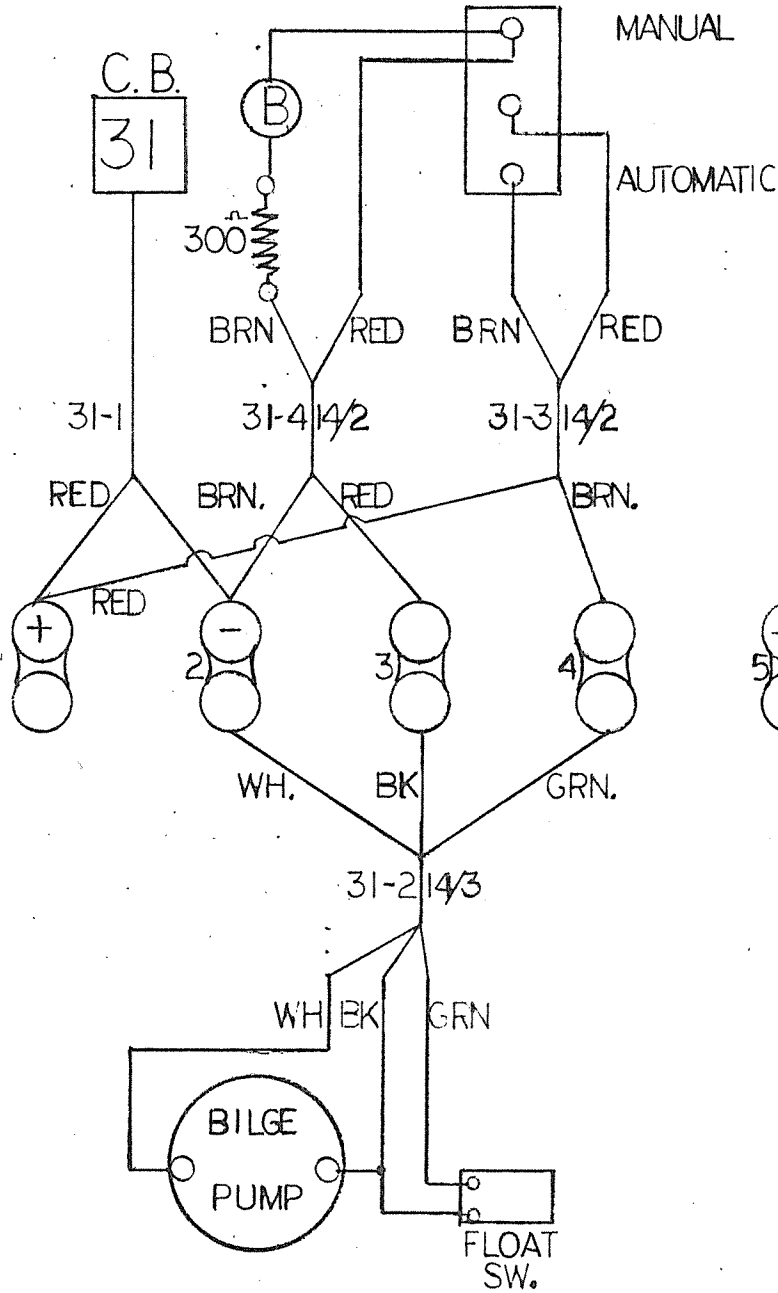

STBD. BLOWER

FWD BILGE PUMP

BRIDGE CONSOLE

BRIDGE CONSOLE

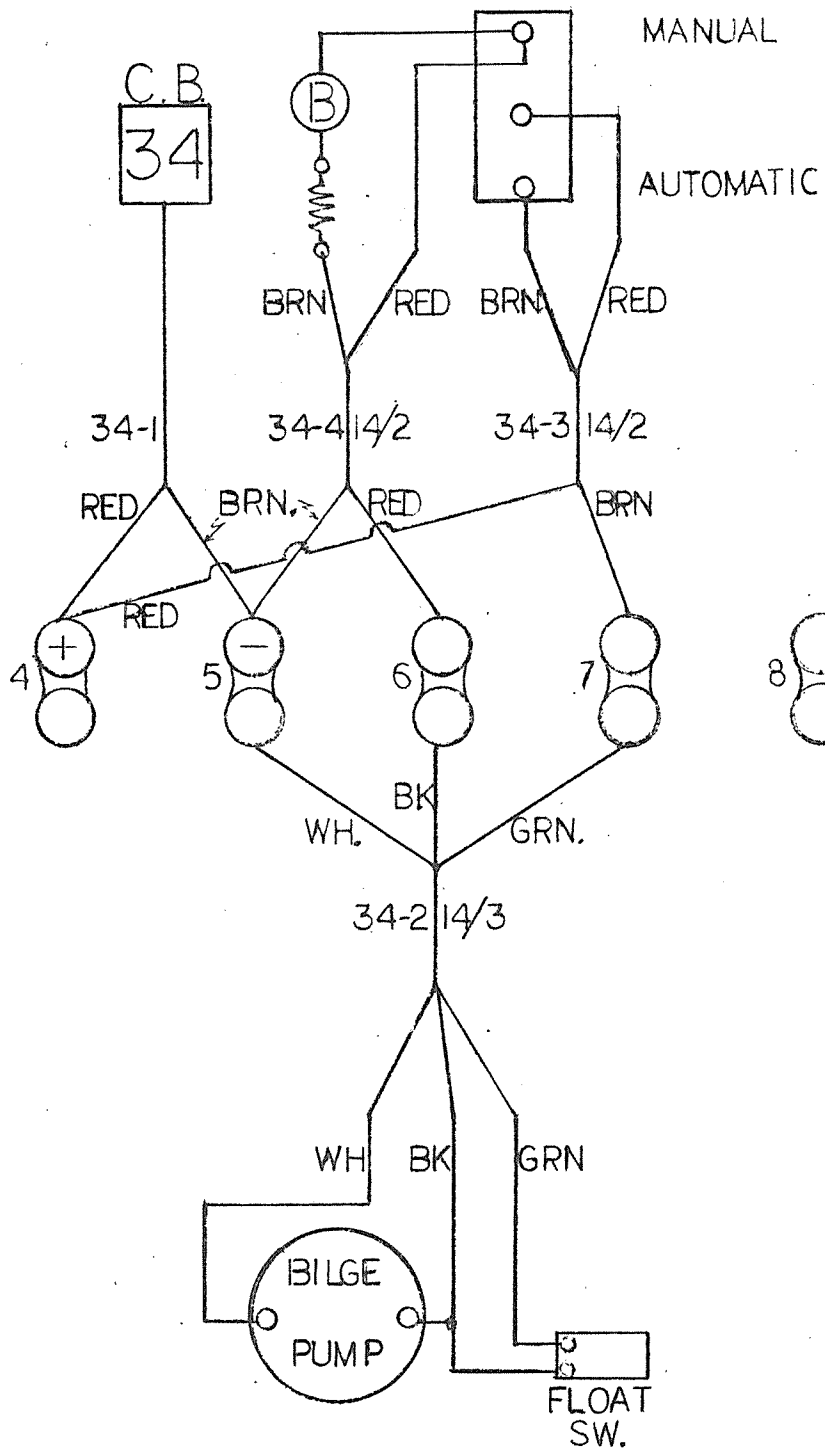
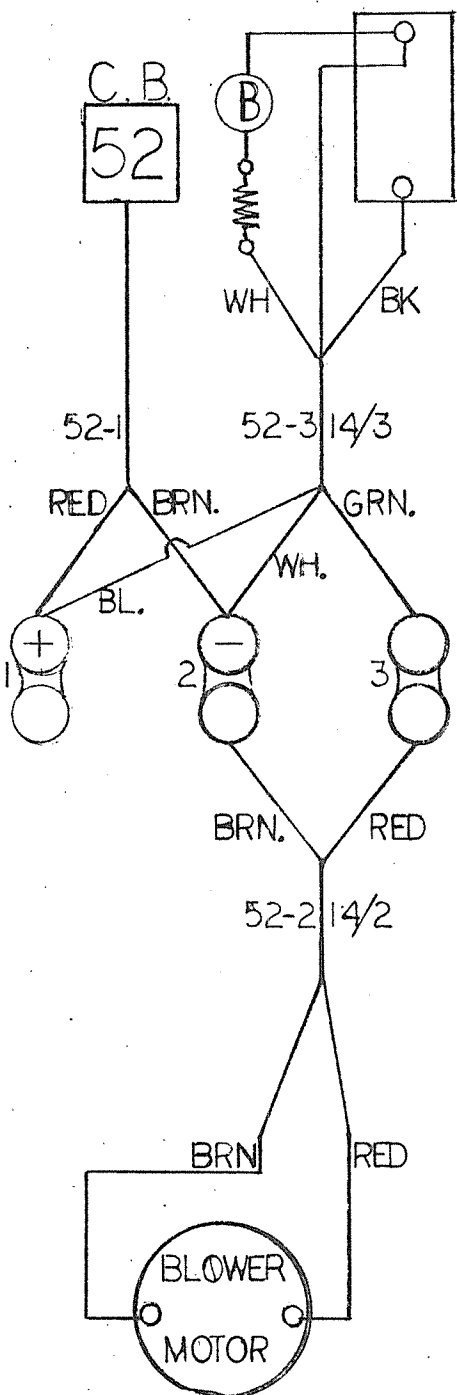

585

TBIC-2
32 DC #16

NAVIGATION LIGHTS

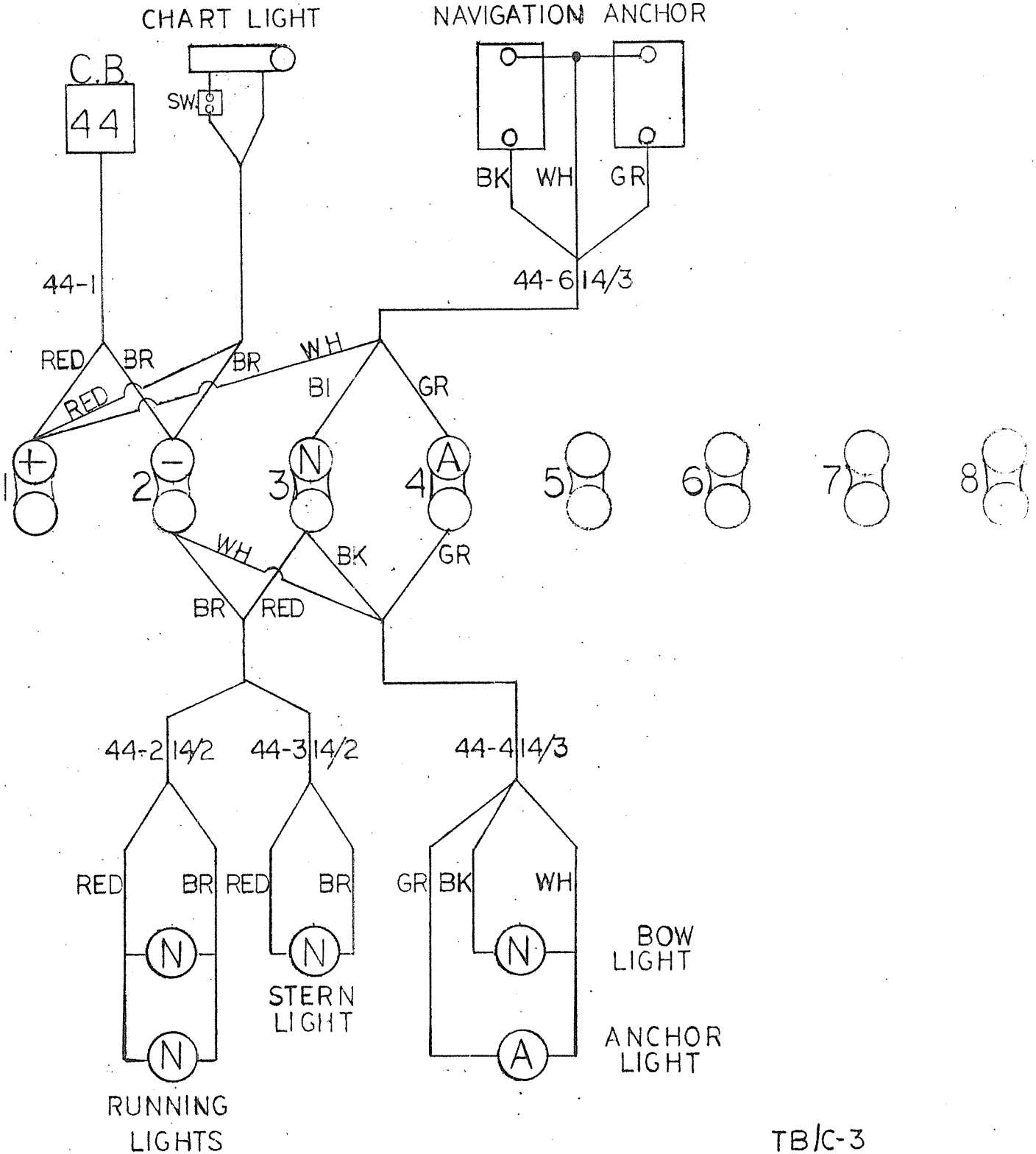

AUTO BLOWER

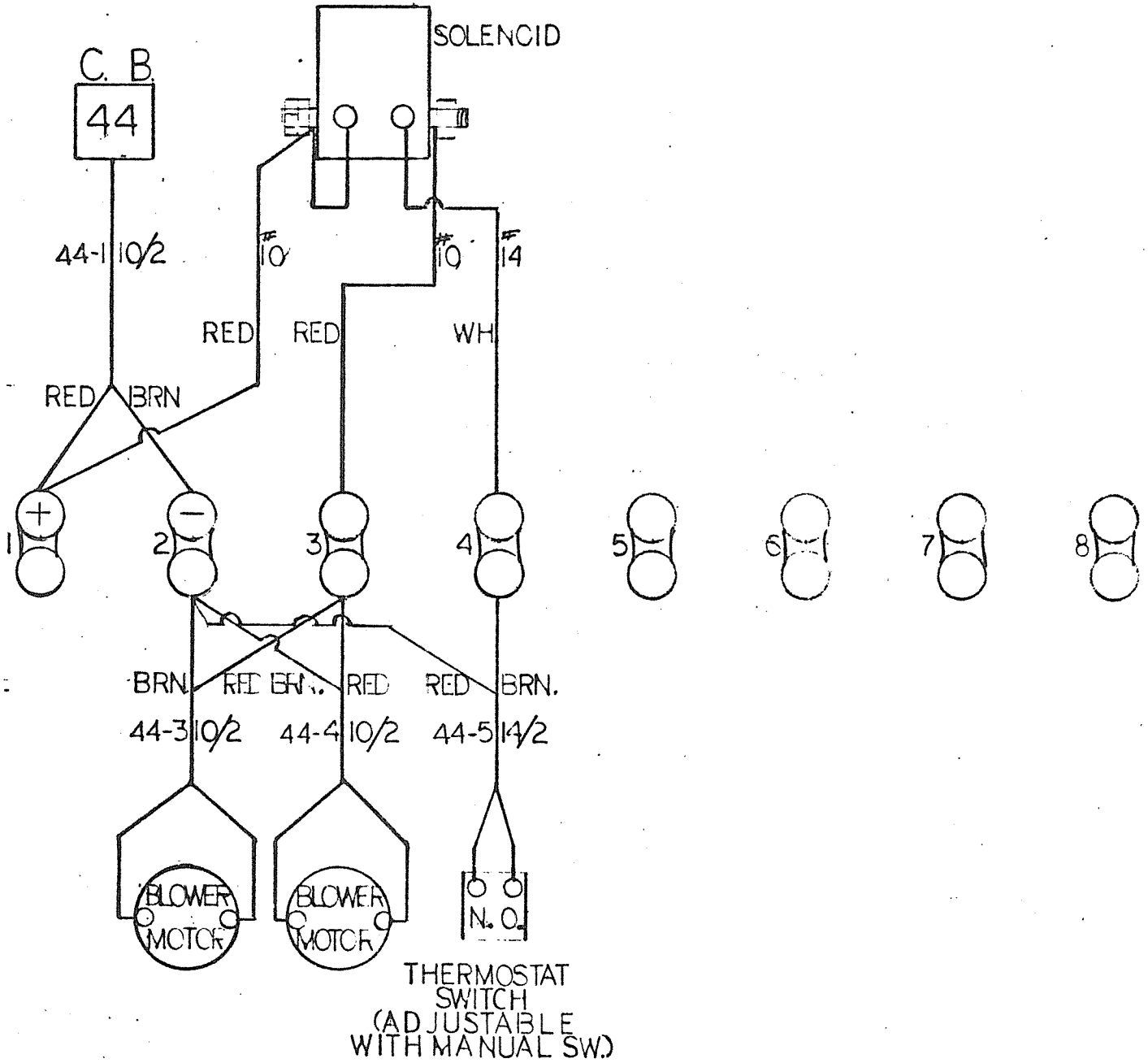

REV. A

TB/C-4
585 32DC 18

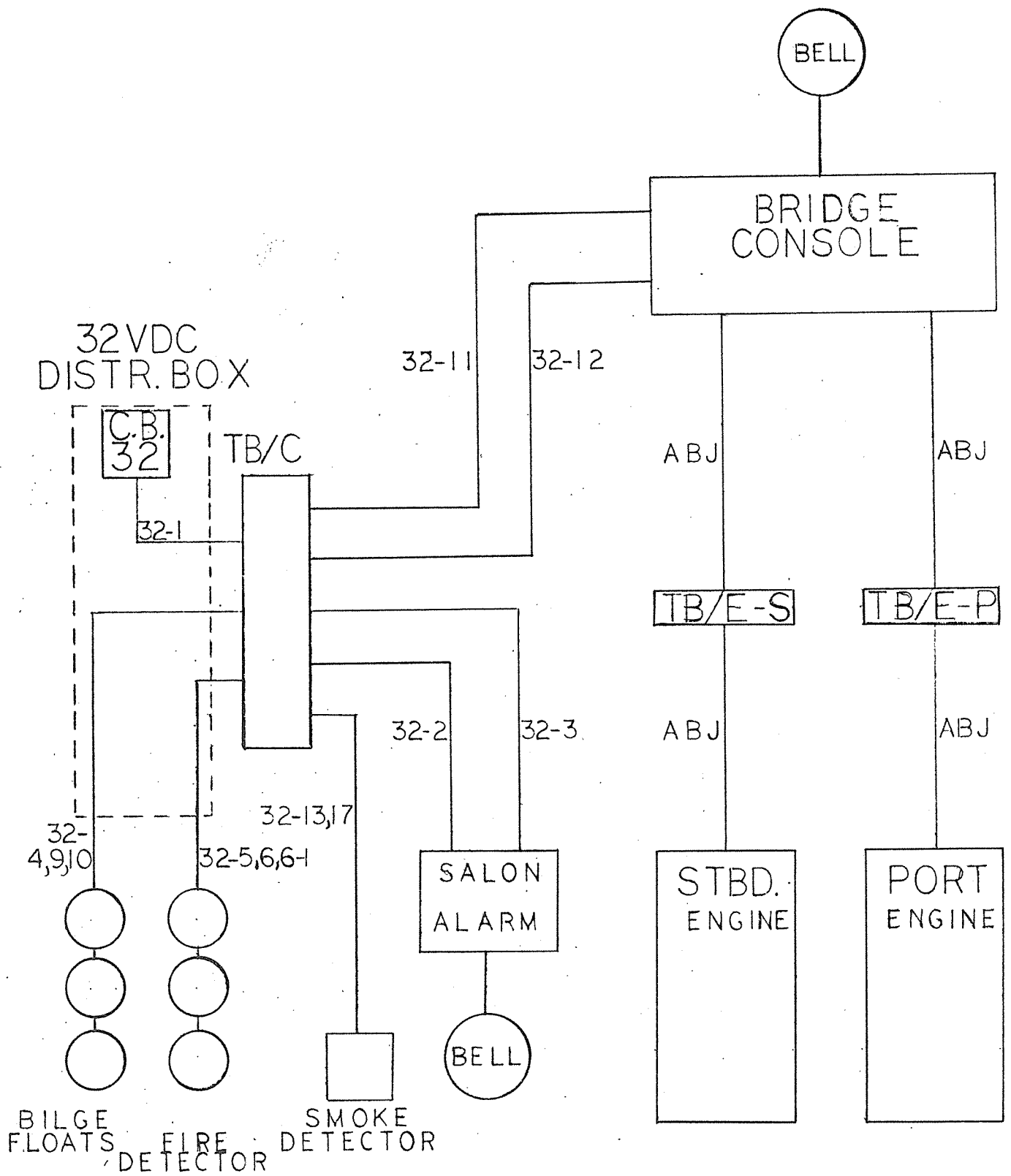

SAFETY ALARM SYSTEM
BLOCK DIAGRAM

SAFETY ALARM SYSTEM

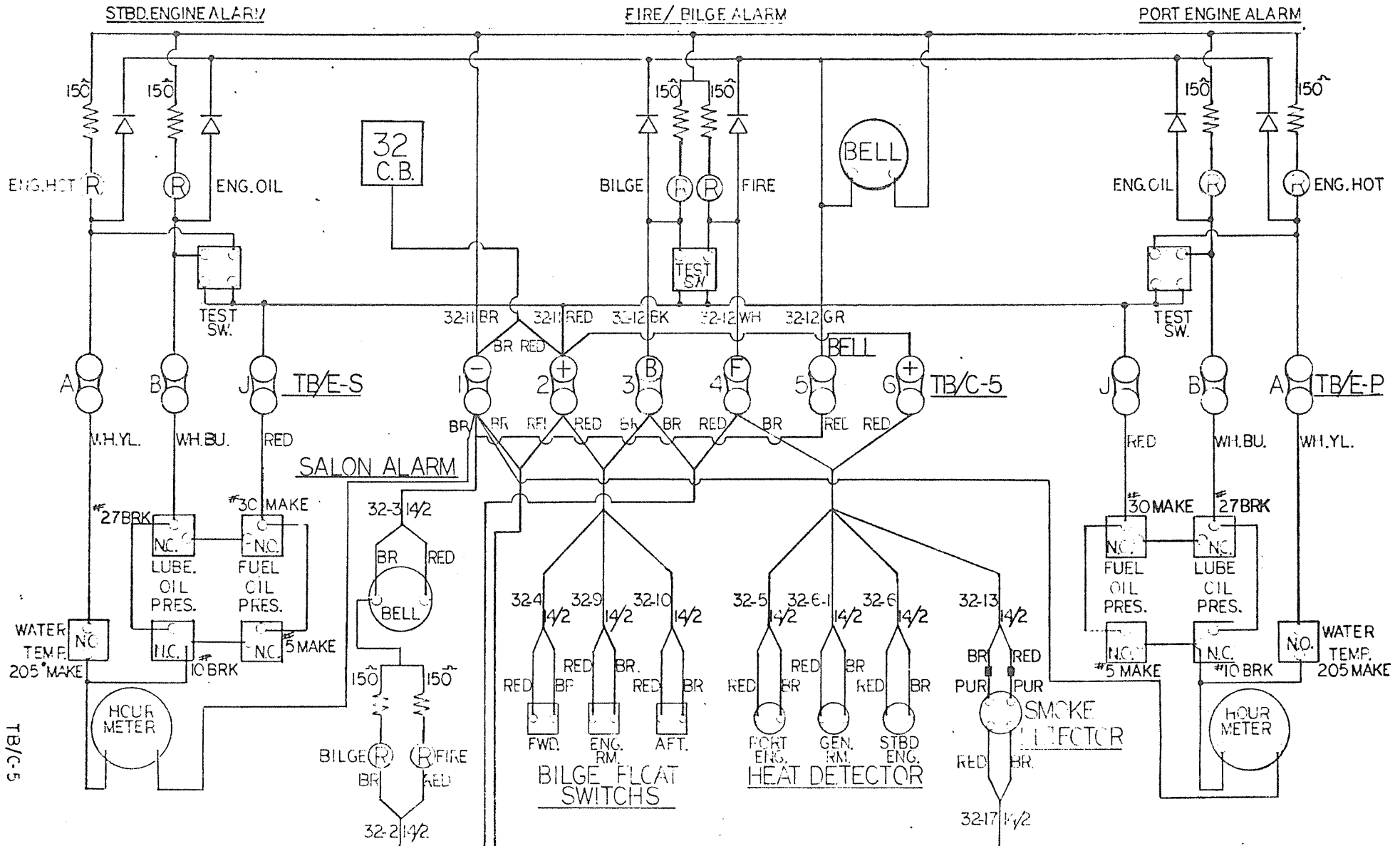

REV A

585 32DC #20

TB/C-5

TRIM, TA3S

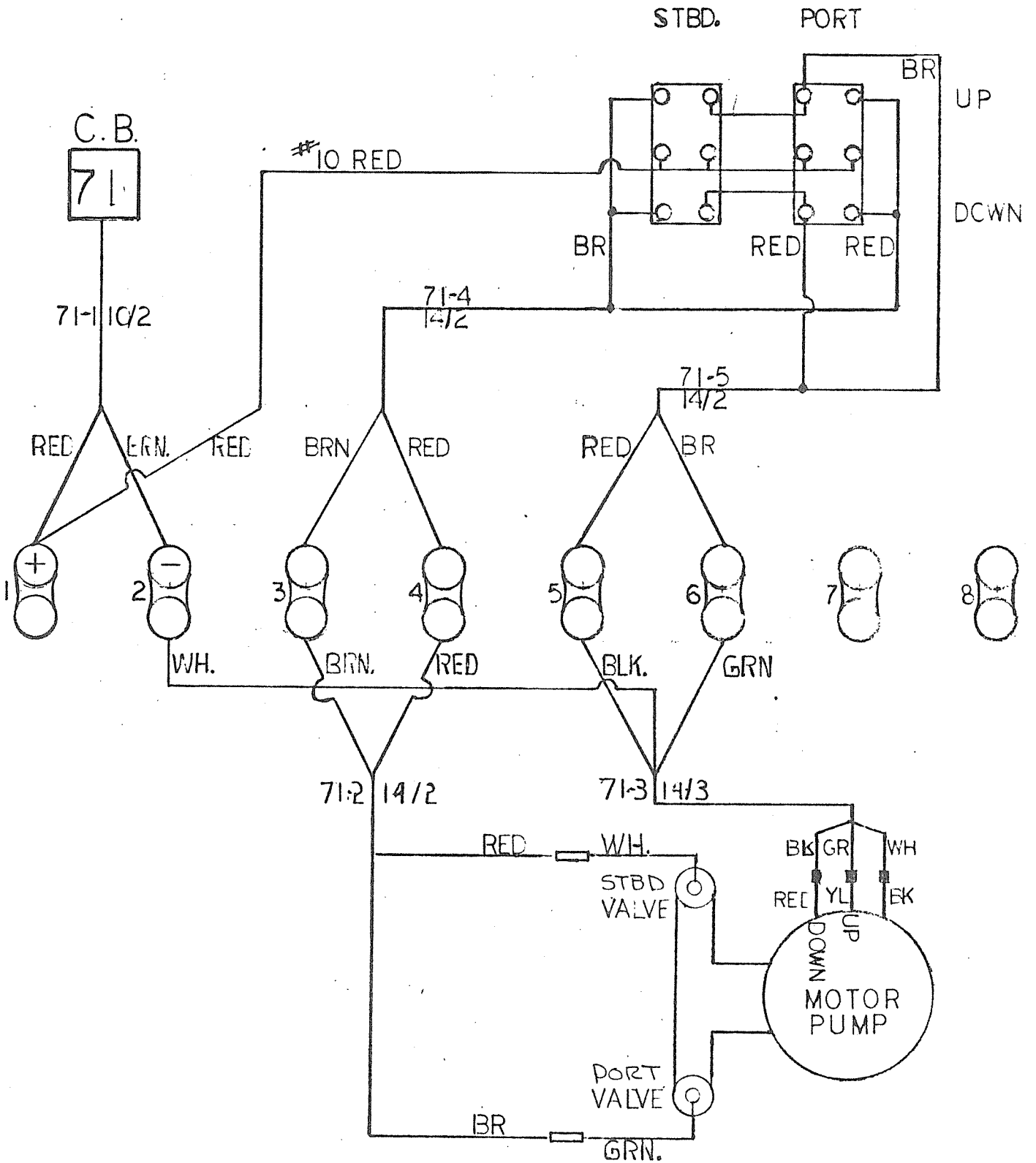

TB/C-6

Rev. A

585

32DC #21

ENGINE TERMINAL BLOCKS TB/E PORT & STARBOARD
UNDER BRIDGE CONSOLE

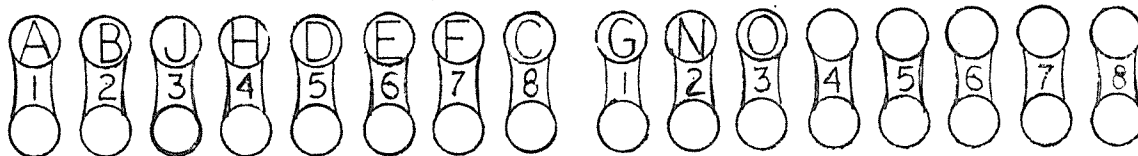

Terminals are not marked, identify by position and wire color.

STANDARD BERTRAM ENGINE LOOM

| <u>SYM</u> | <u>SIZE</u> | <u>COLOR</u> | <u>USE</u> |
|------------|-------------|----------------|-----------------------------------|
| A | 14 | Wh - Yel | Alarm - Water Temperature |
| B | 14 | Wh - Bl | Alarm - Lube Oil Pressure |
| J | 14 | Red | Alarm - Power |
| H | 14 | Wh - Red - Bl | Battery Parallel (stbd only) |
| D | 10 | White | Negative Common |
| F | 10 | Wh - Blk - Orn | Ignition Switch Feed |
| E | 10 | Wh - Orn | Ignition |
| C | 10 | Wh - Grn | Stop |
| G | 14 | Wh - Red | Start |
| I | 14 | Red - Wh | |
| N | 16 | White | Tachometer |
| O | 16 | Wh - Blk | Tachometer |
| L | 16 | Yellow | Water Temperature |
| M | 16 | Black | Gear Oil Pressure (without Omega) |
| K | 16 | Blue | Engine Oil Pressure |

EXTRA WIRES (NOT INSIDE BERTRAM LOOM)

| | | | |
|---|----|----------------|--------------------------------------|
| X | 10 | Wh - Blk - Grn | Ignition Switch Return (2 Sta. Only) |
|---|----|----------------|--------------------------------------|

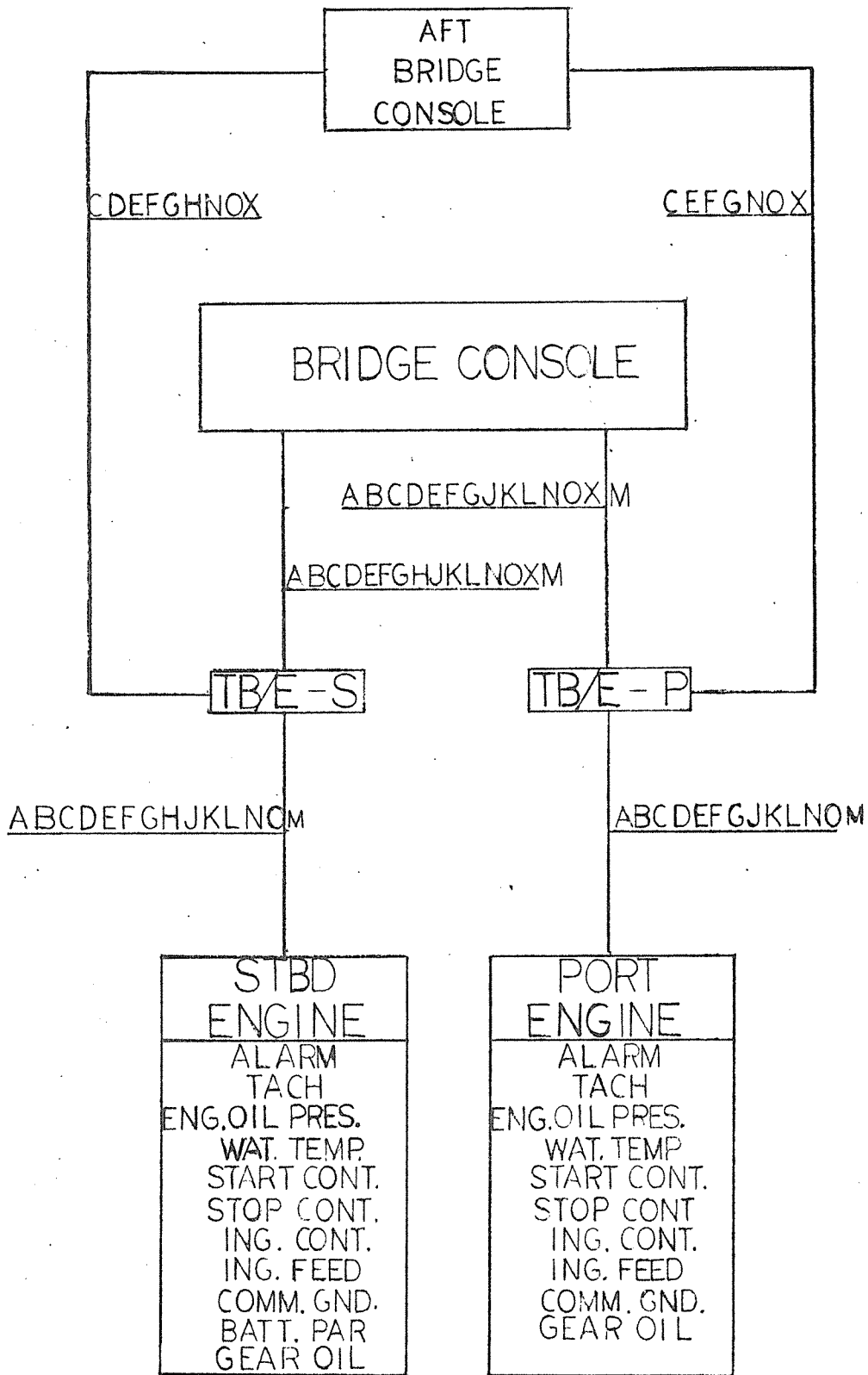

ENGINE LOOMS
SHOWING WIRES USED

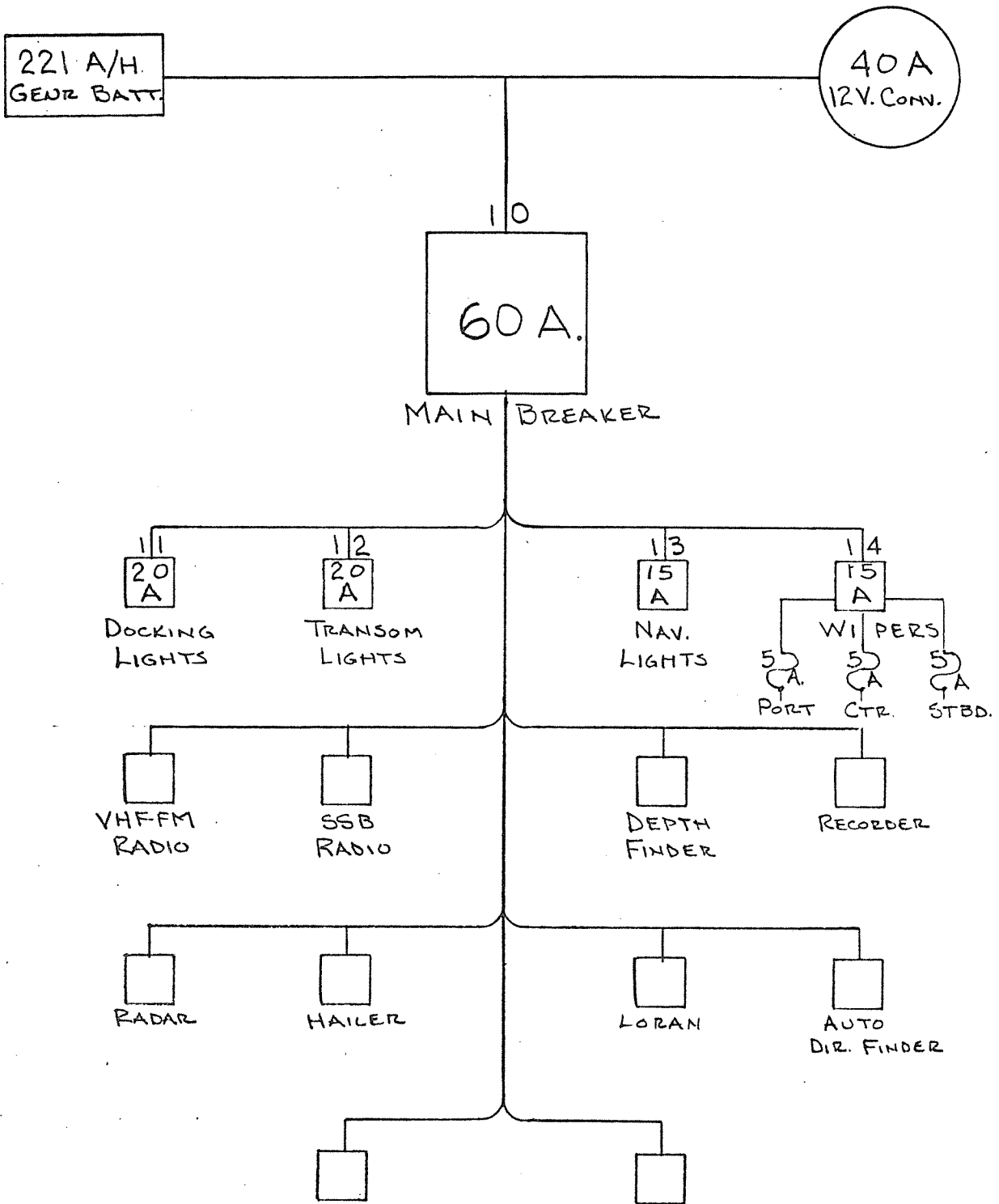

12VDC DISTRIBUTION PANEL
FLOW DIAGRAM

REV. A

585 12DC #1

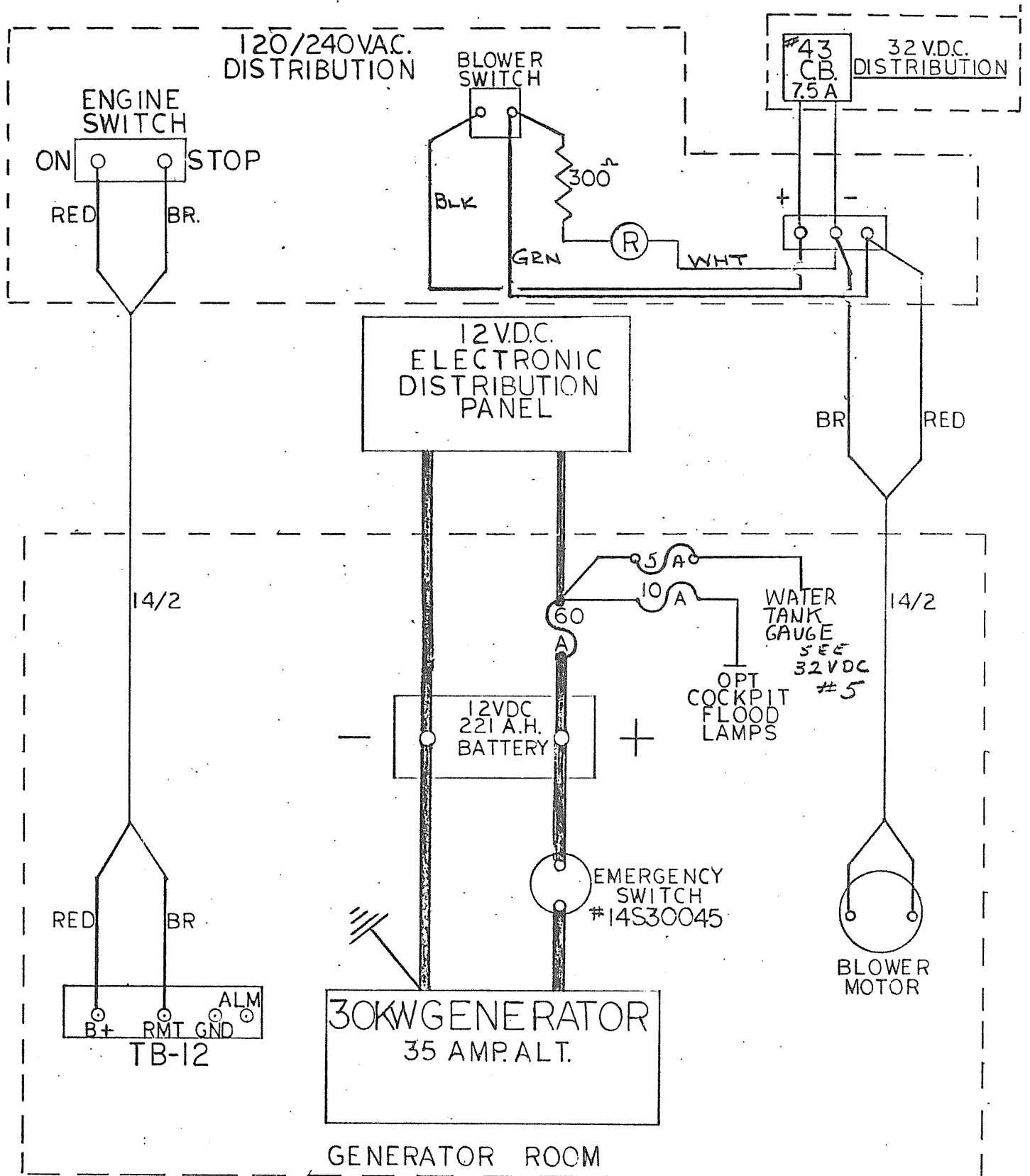

SINGLE GENERATOR CONTROL & WIRING DIAGRAM

REV. A

585 12DC #2

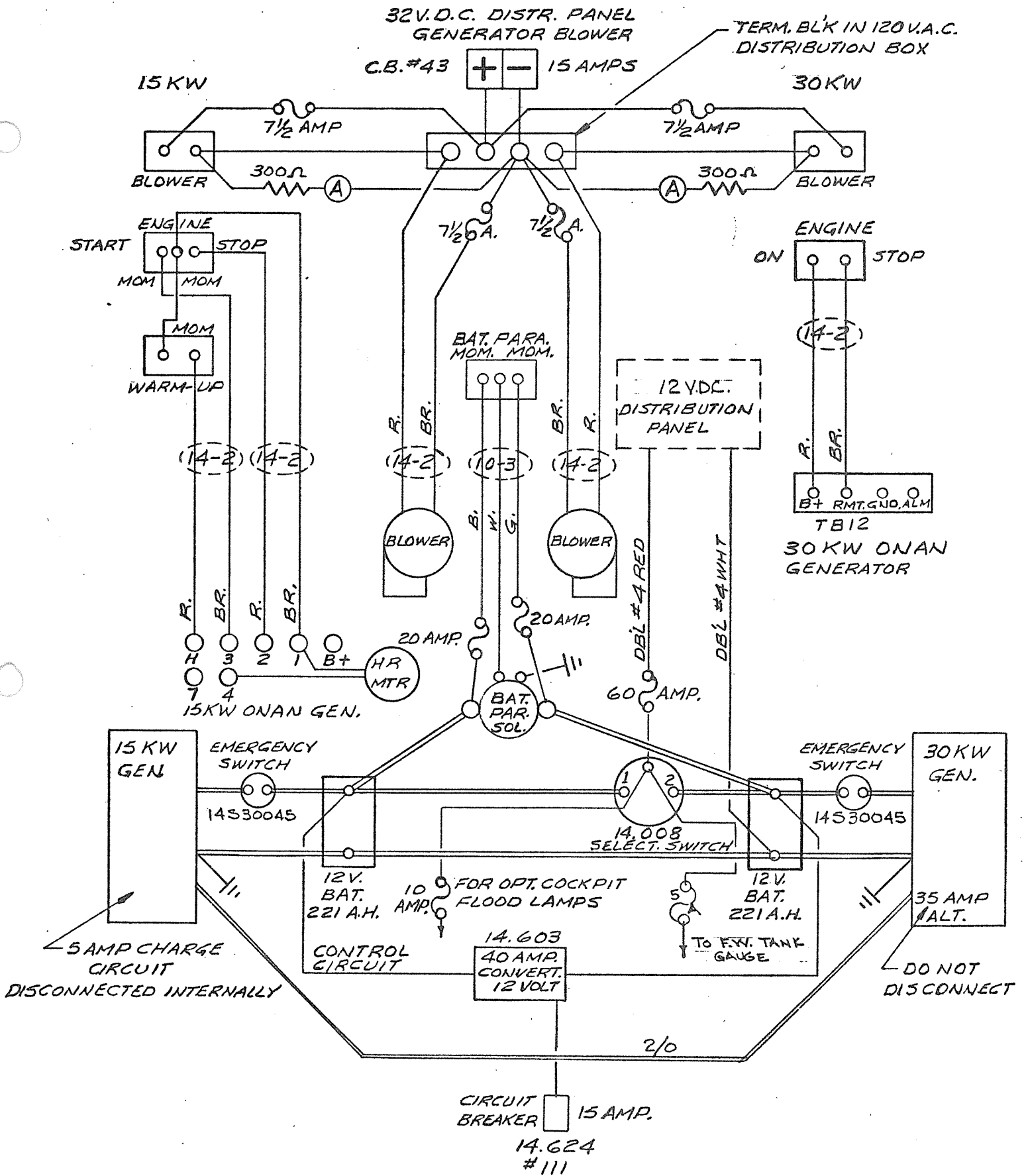

MODEL 585

DUAL GENERATOR CONTROLS & WIRING DIAGRAM & GENERATOR BATTERY CIRCUITS FOR 12V.D.C. ELECTRONIC DISTRIBUTION PANEL (BACK VIEW)

REV. A 585 12DC #3

BOW DOCKING LIGHTS

TRAN. DOCKING LIGHTS

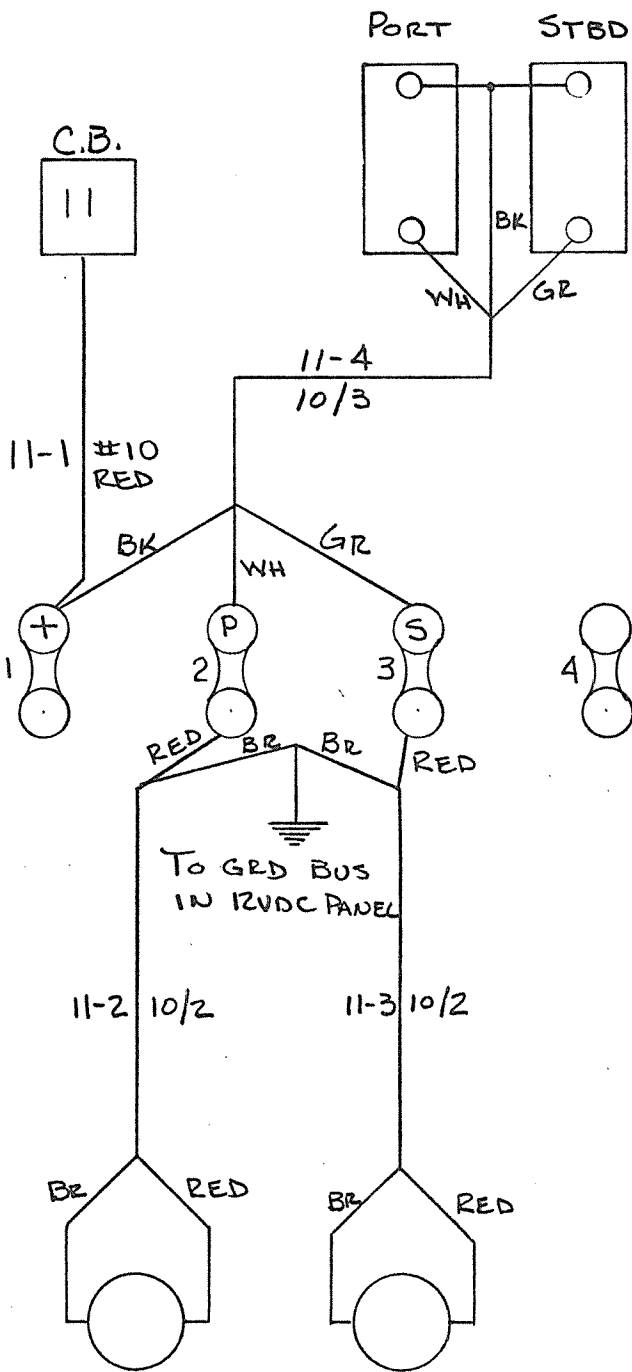

TB/P-2

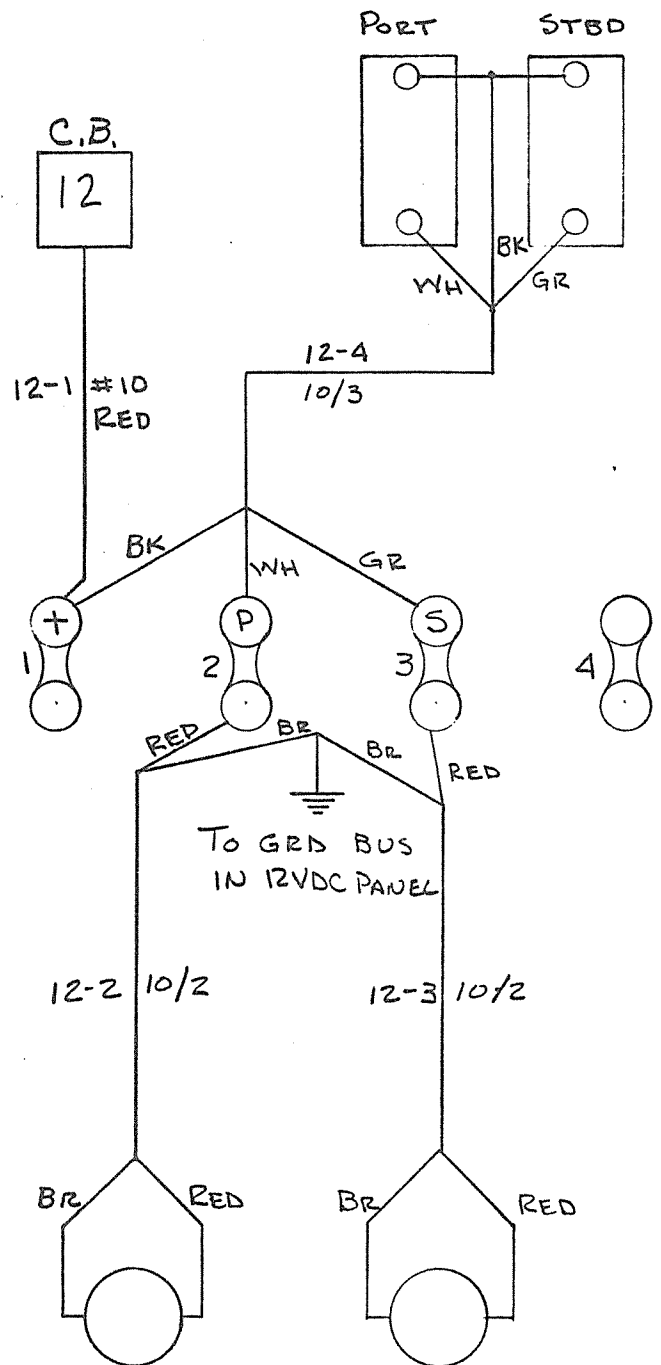

TB/P-3

REV. A

585

12DC#4

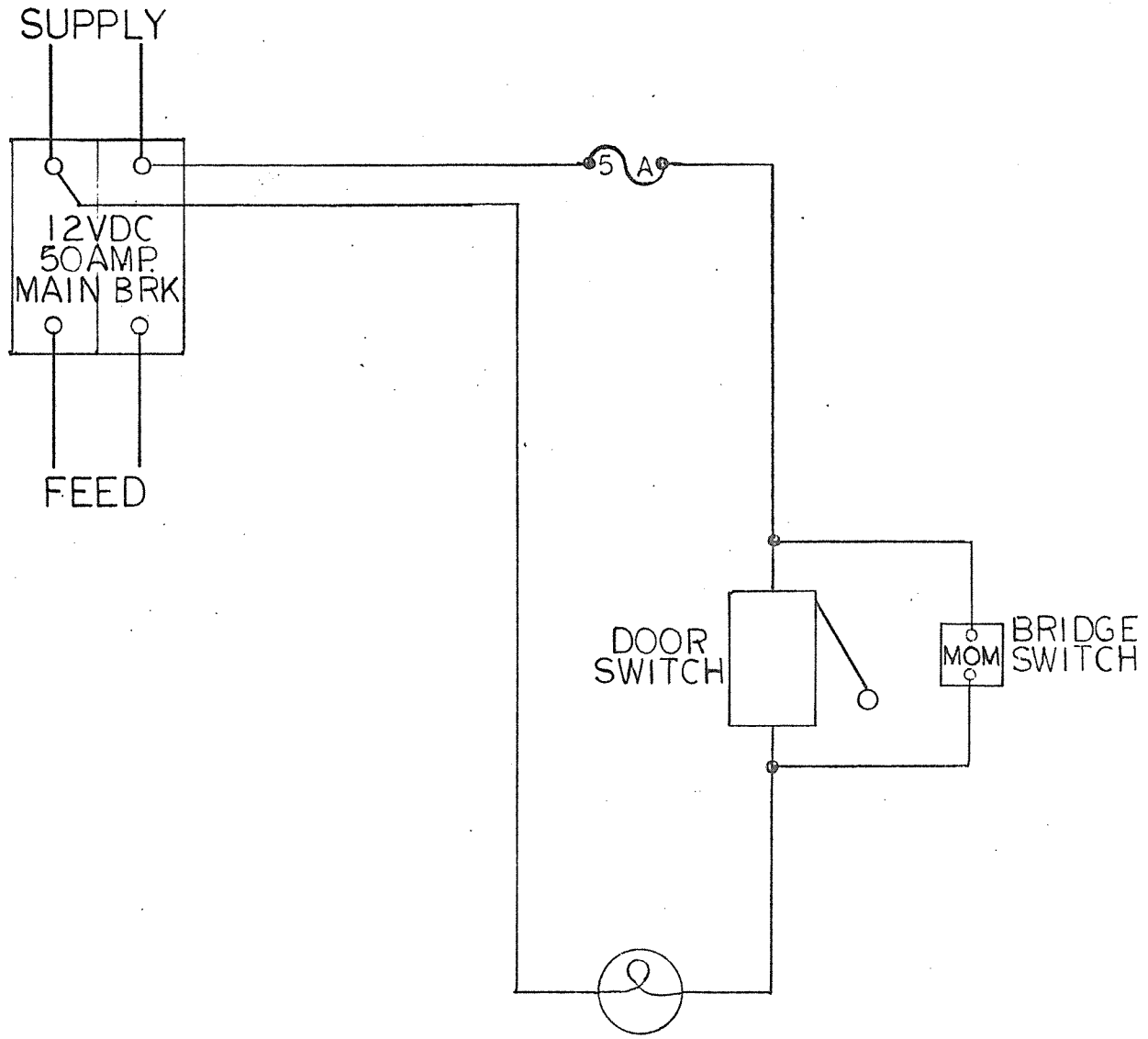

12V.DC PANEL LIGHT

585 12DC #5

NAVIGATION LIGHTS

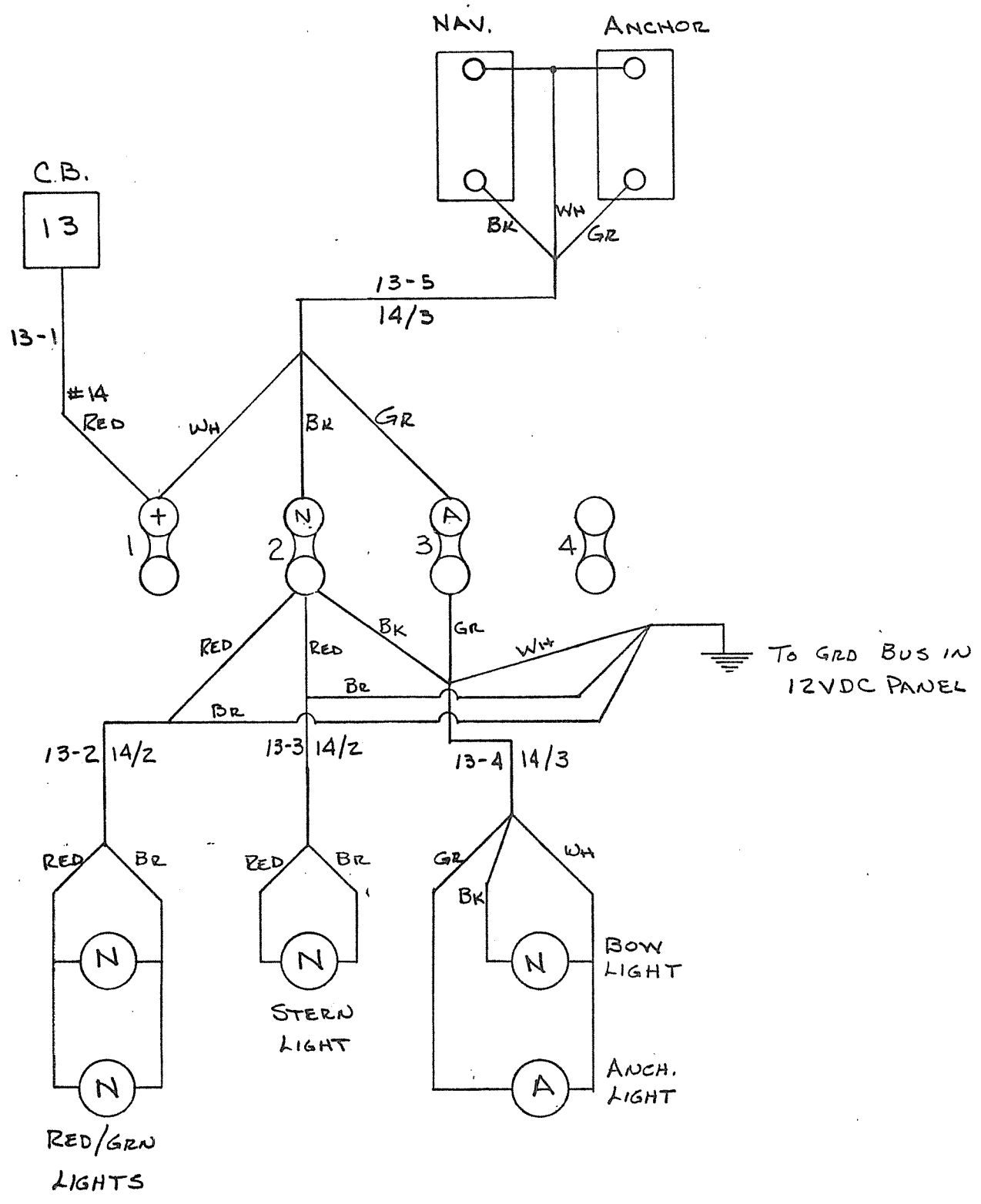

585

TB/P-1
12DC#6

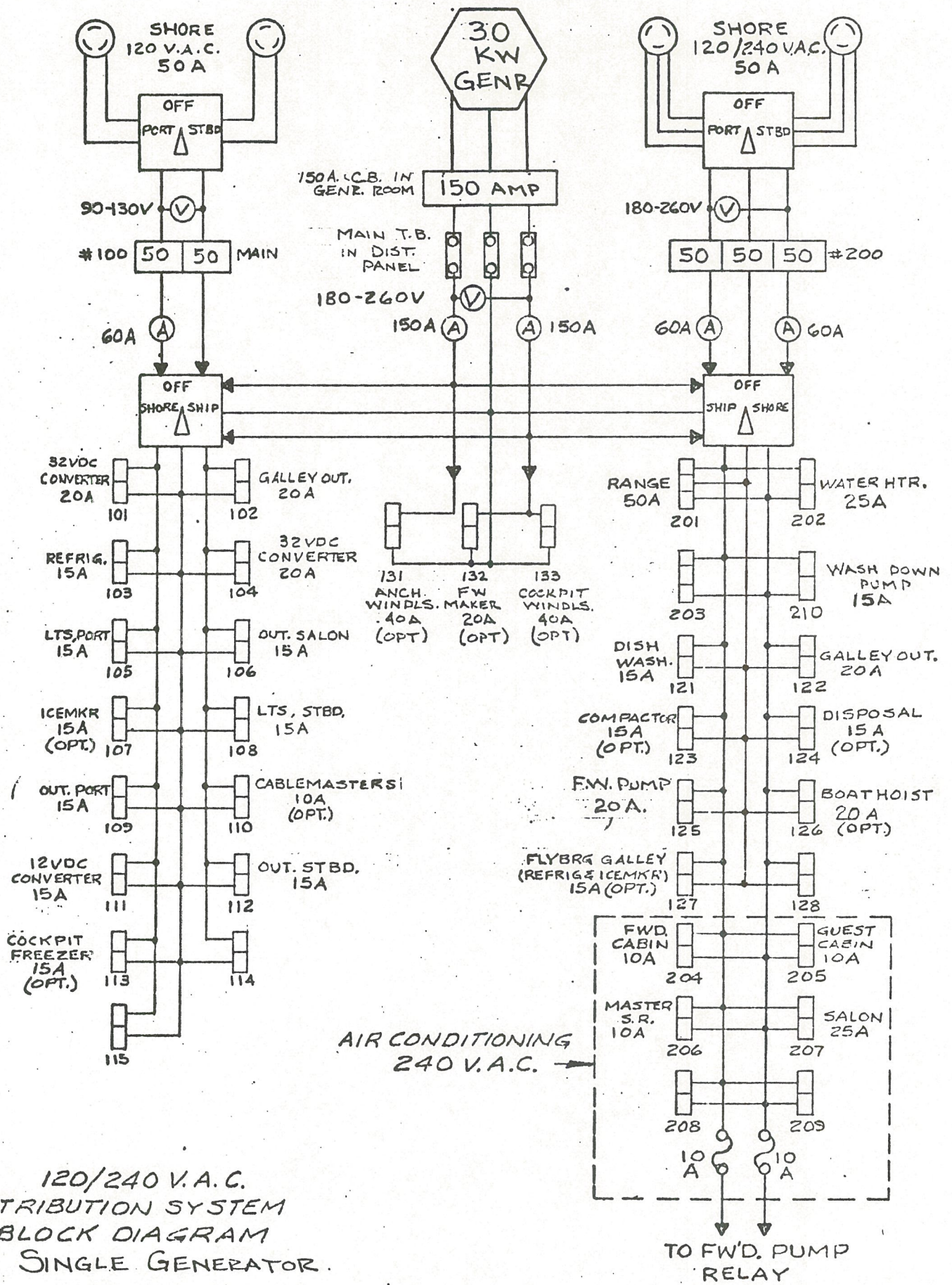

120/240 V.A.C.
 DISTRIBUTION SYSTEM
 BLOCK DIAGRAM
 SINGLE GENERATOR.
 MODEL 585

REV. A

585 AC #1

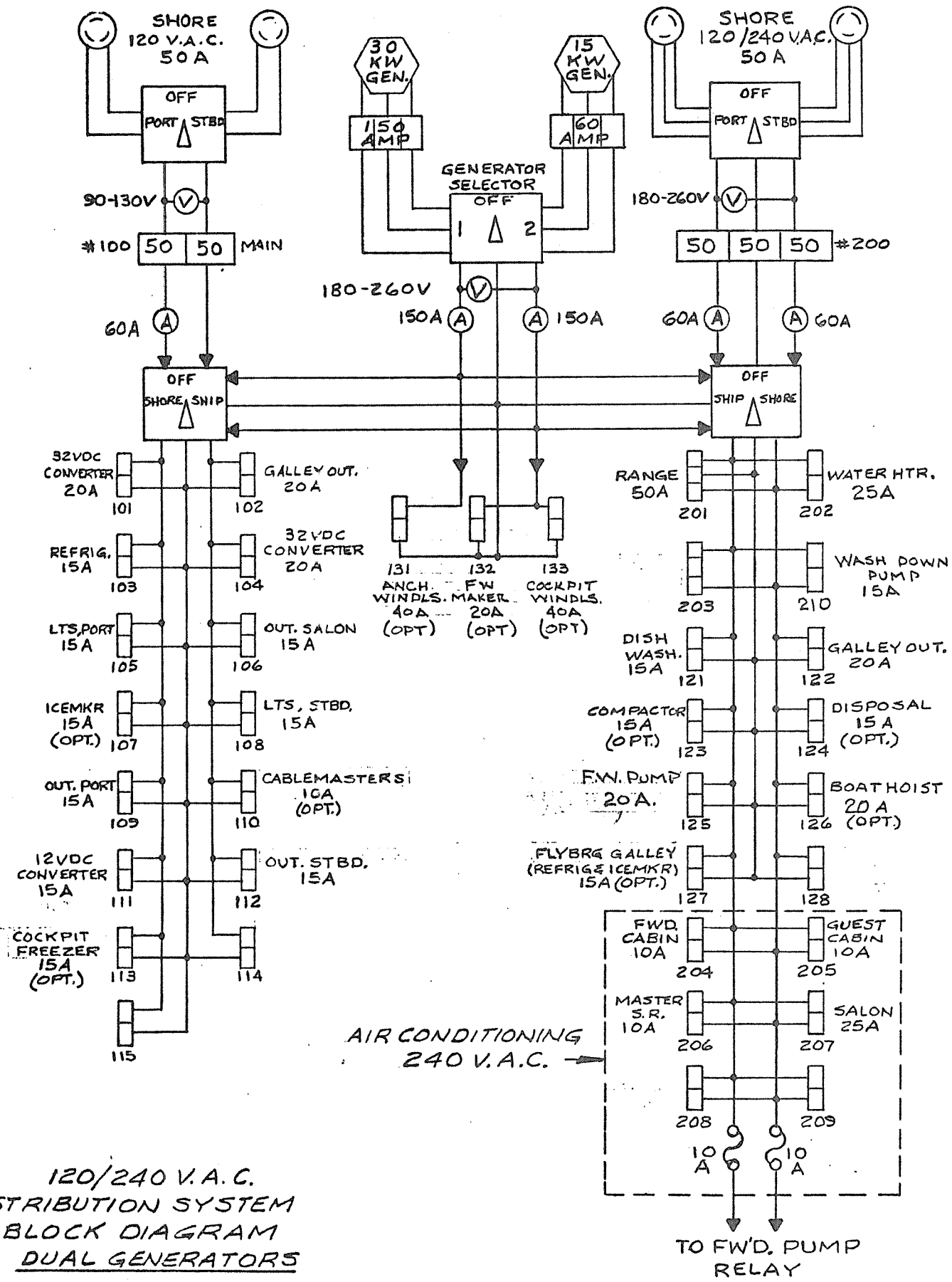

120/240 V.A.C.
 DISTRIBUTION SYSTEM
 BLOCK DIAGRAM
 DUAL GENERATORS

MODEL 585

REV. A

585 AC[#]2

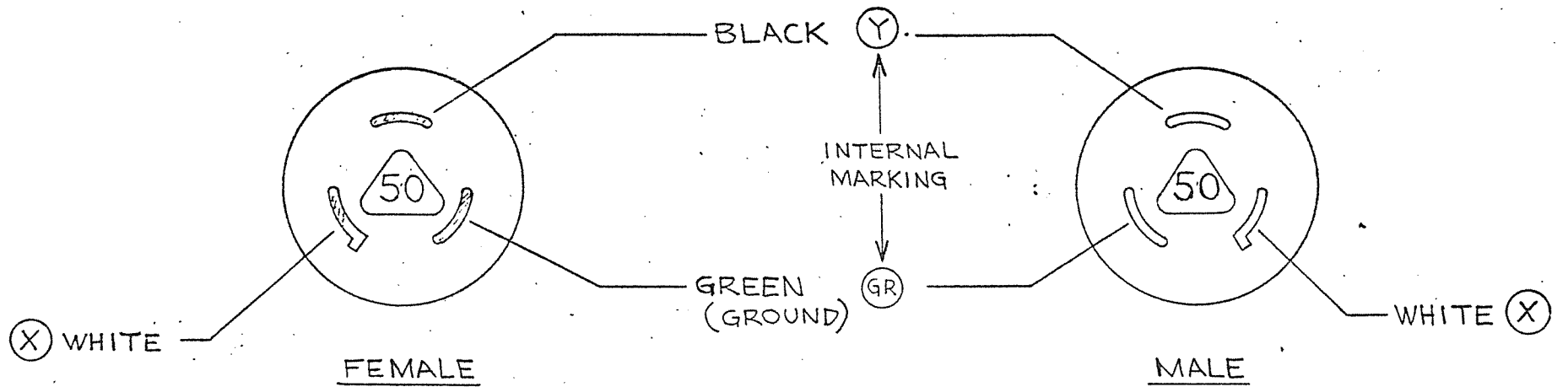

SHORE CORD (50 FT) & INLET — 50 AMP-125 V
2 POLE — 3 WIRE

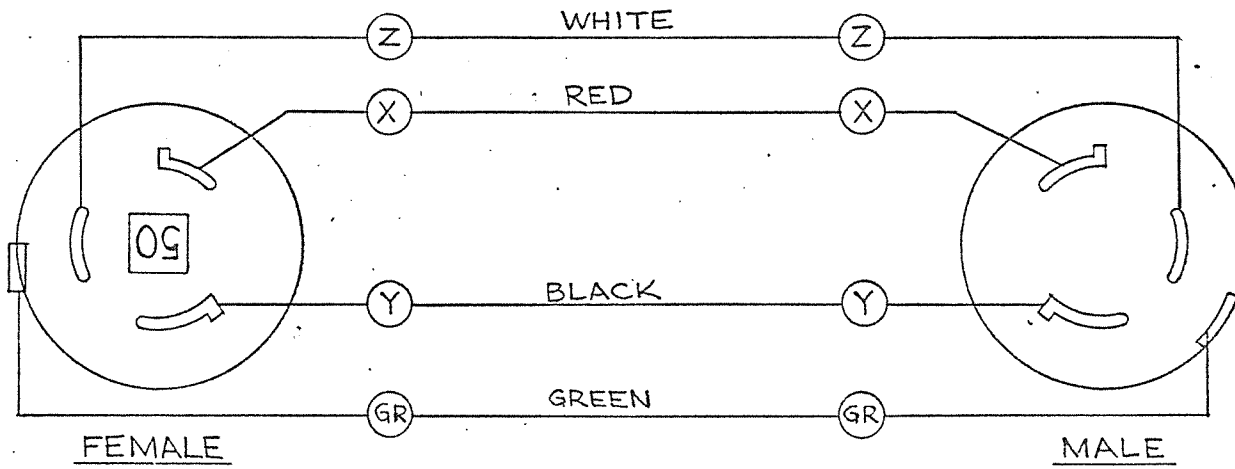

SHORE CORD (50 FT) & INLET — 50 AMP
125/250 VOLT 3 POLE — 4 WIRE

585 AC #3

FROM MAIN T.B.

REV. A

5851AC#4

120/240 SHORE POWER
WIRING DIAGRAM
BACK VIEW

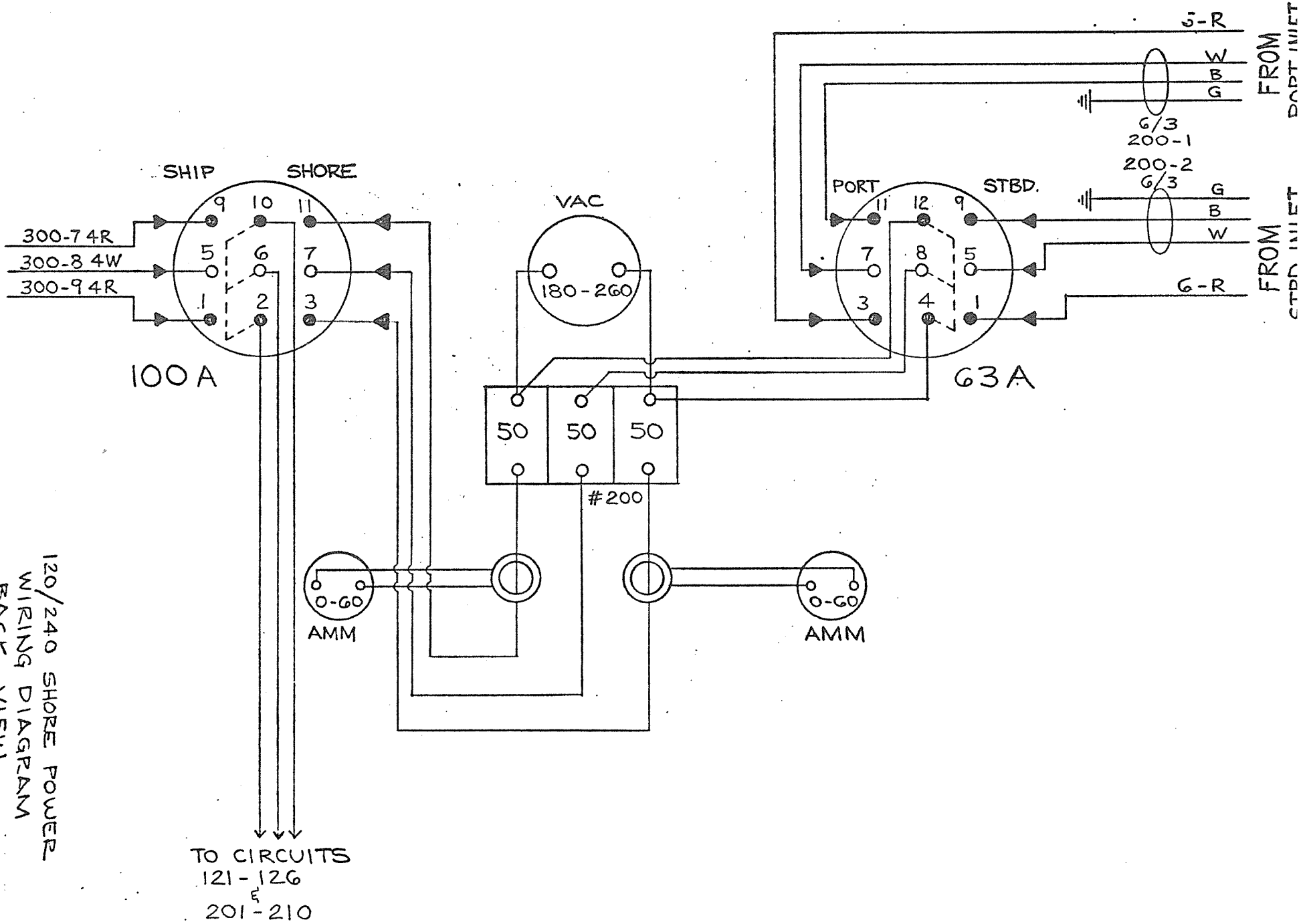

TO CIRCUITS
121-126
201-210

FROM DAPT INLET
FROM STBD INLET

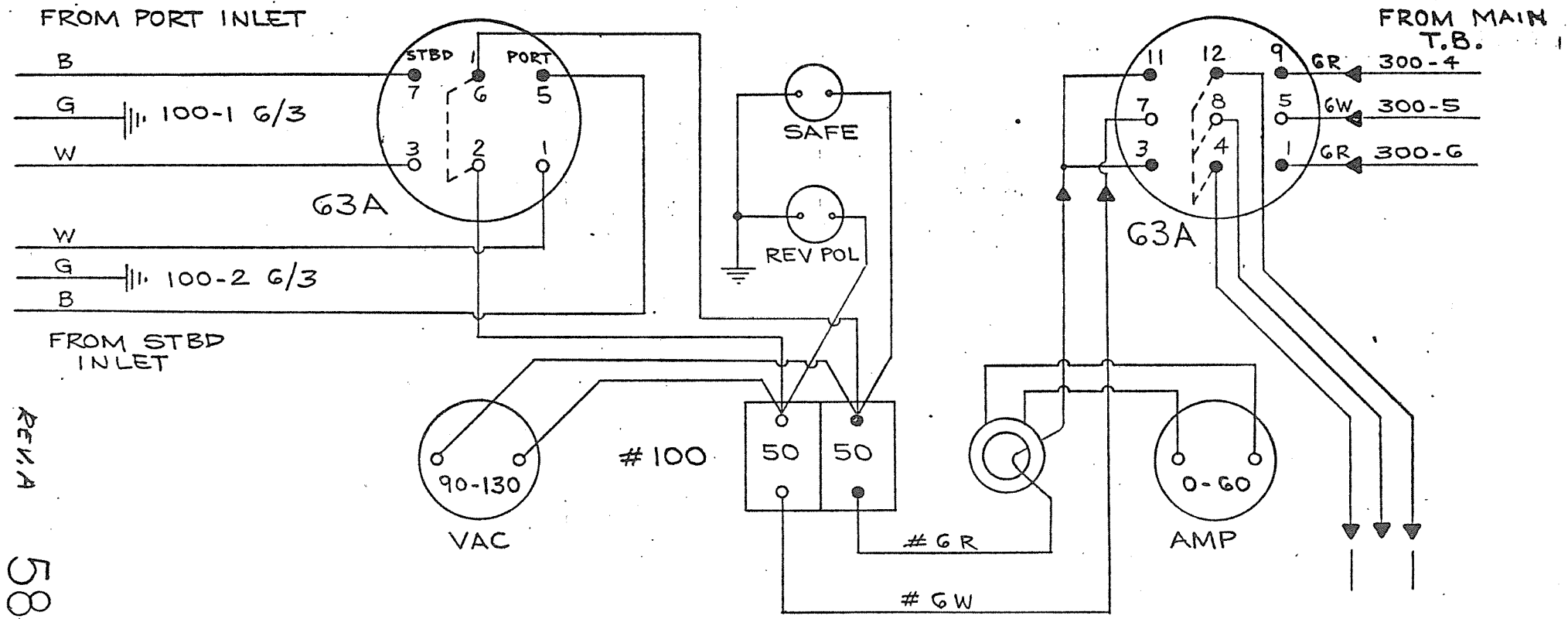

REV. A
 585 AC #5

120 VAC SHOREPOWER
 WIRING DIAGRAM
 BACK VIEW

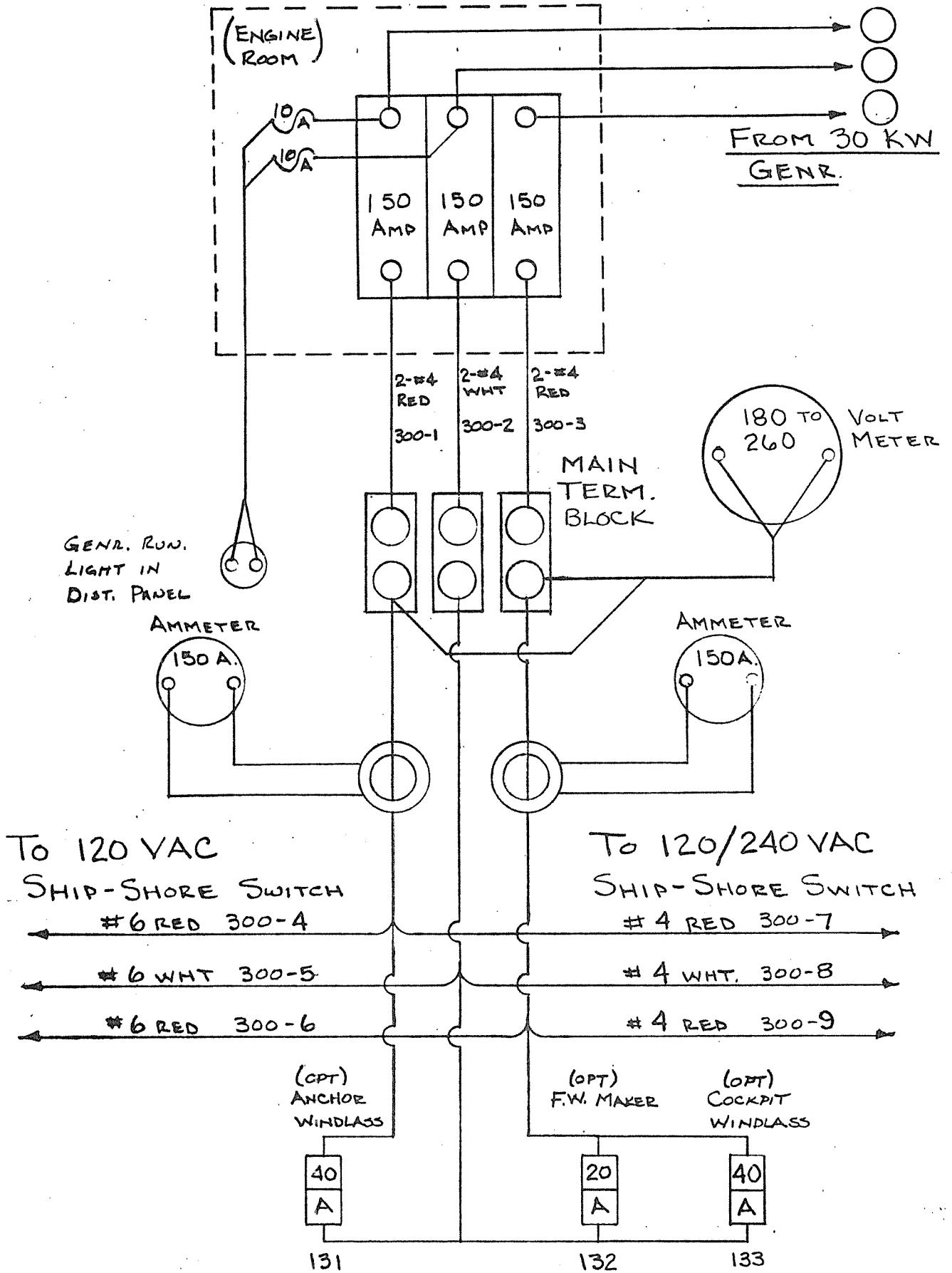

120/240 VAC. SINGLE GENR.
WIRING DIAGRAM

REV. A

585 AC #6

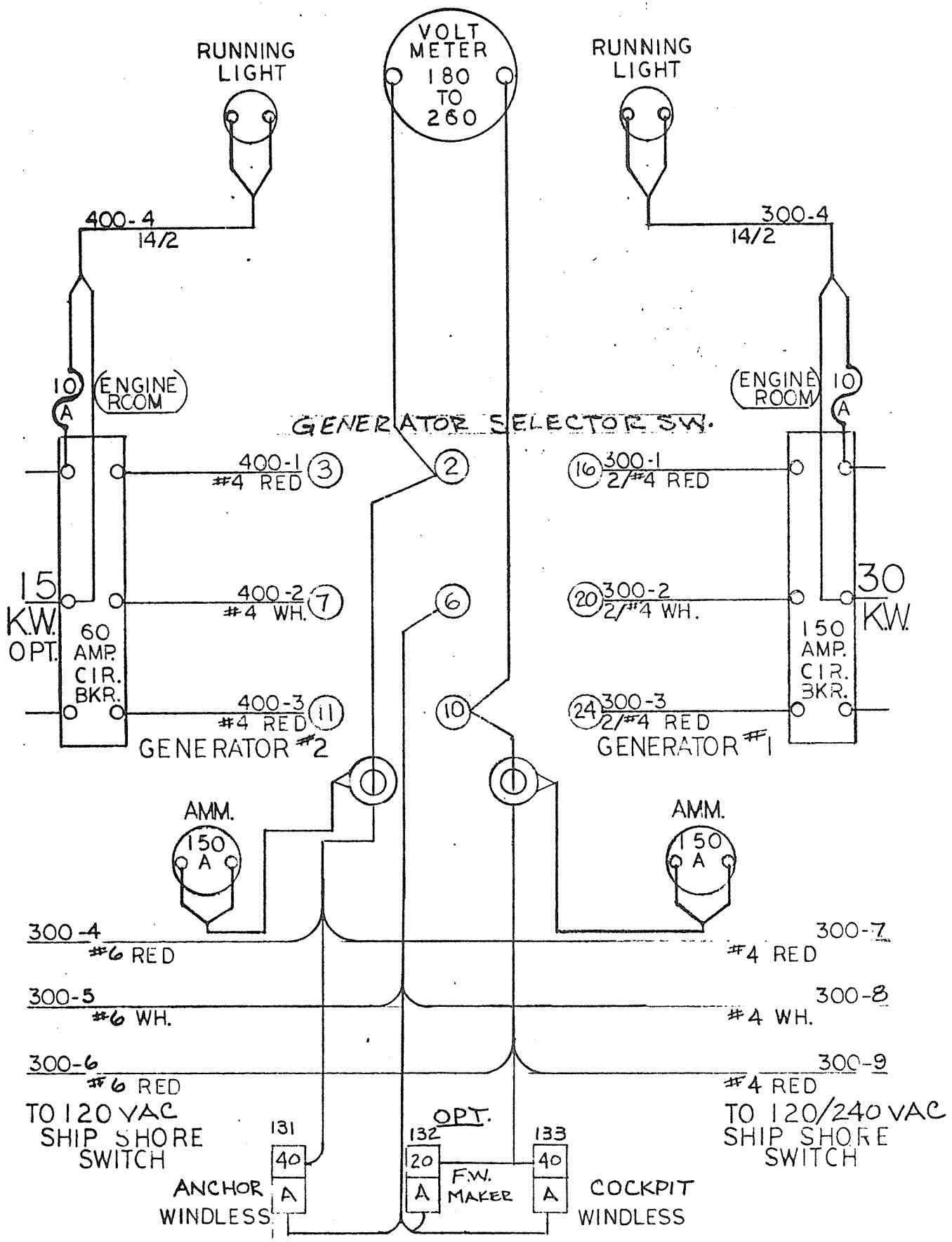

120/240 VAC. DUAL GENERATOR
WIRING DIAGRAM
(BACK VIEW)

MASTER CABIN

GUEST CABIN

FORWARD CABIN

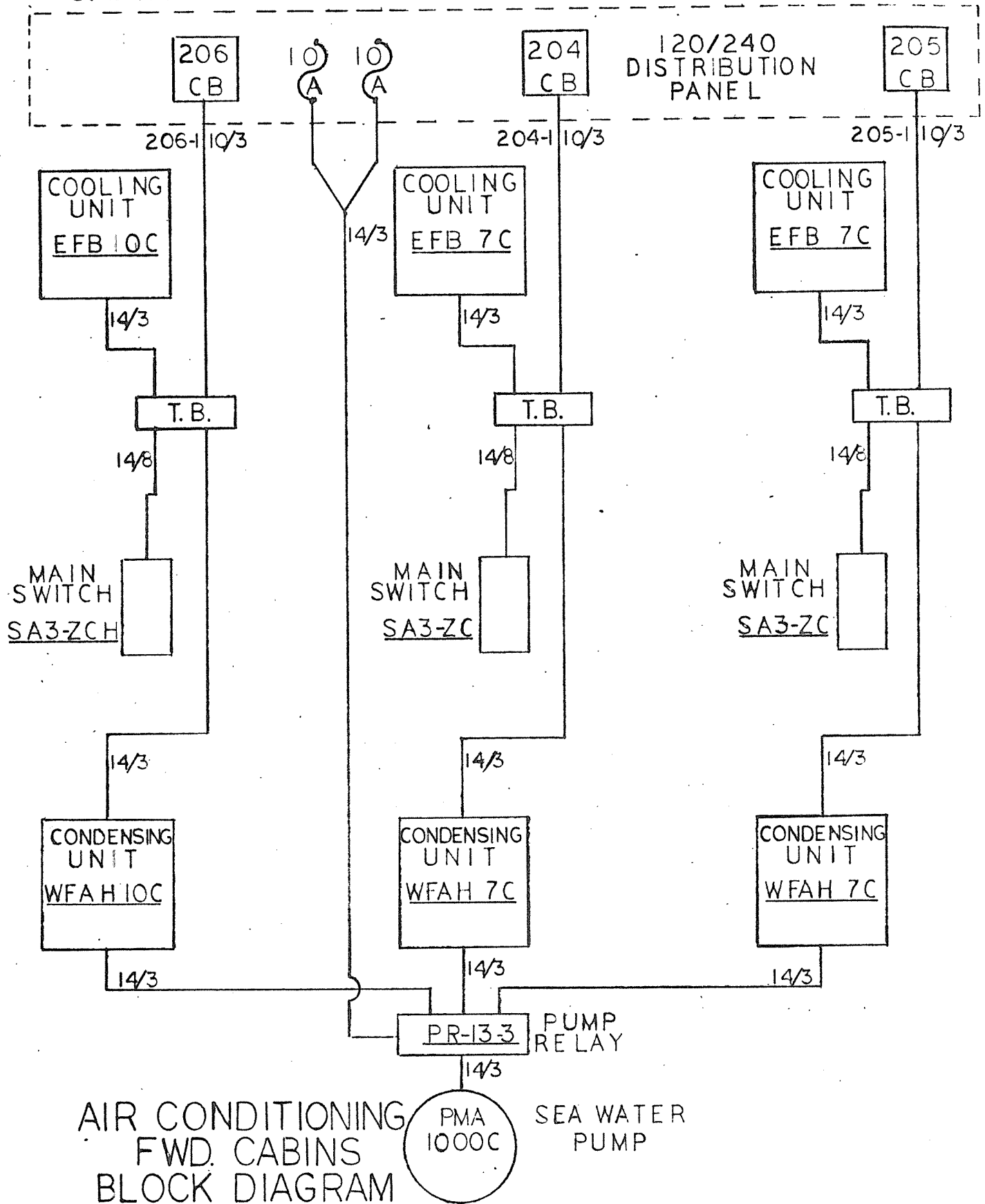

AIR CONDITIONING
FWD. CABINS
BLOCK DIAGRAM

SEA WATER
PUMP

585 AC #8

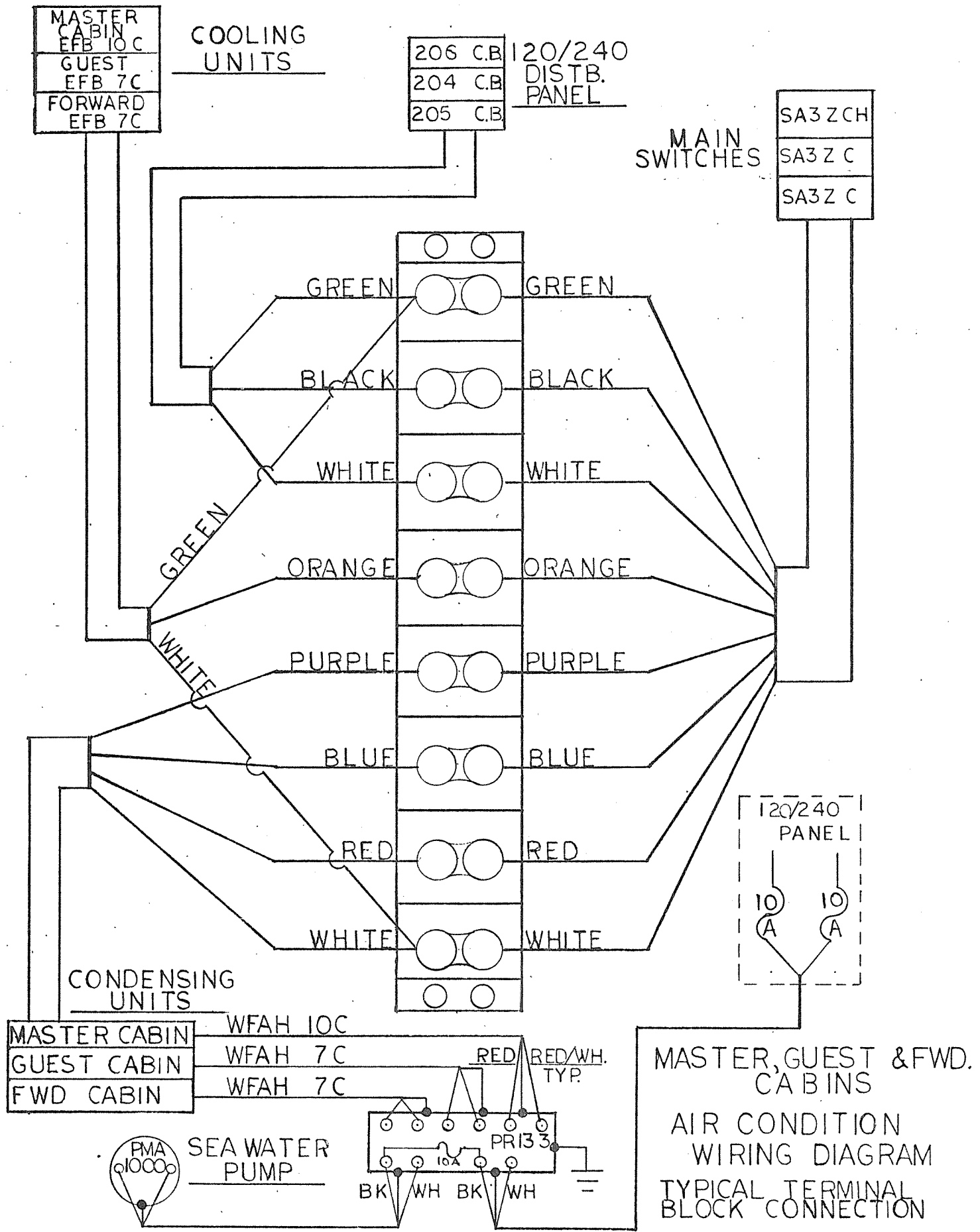

585

AC#9

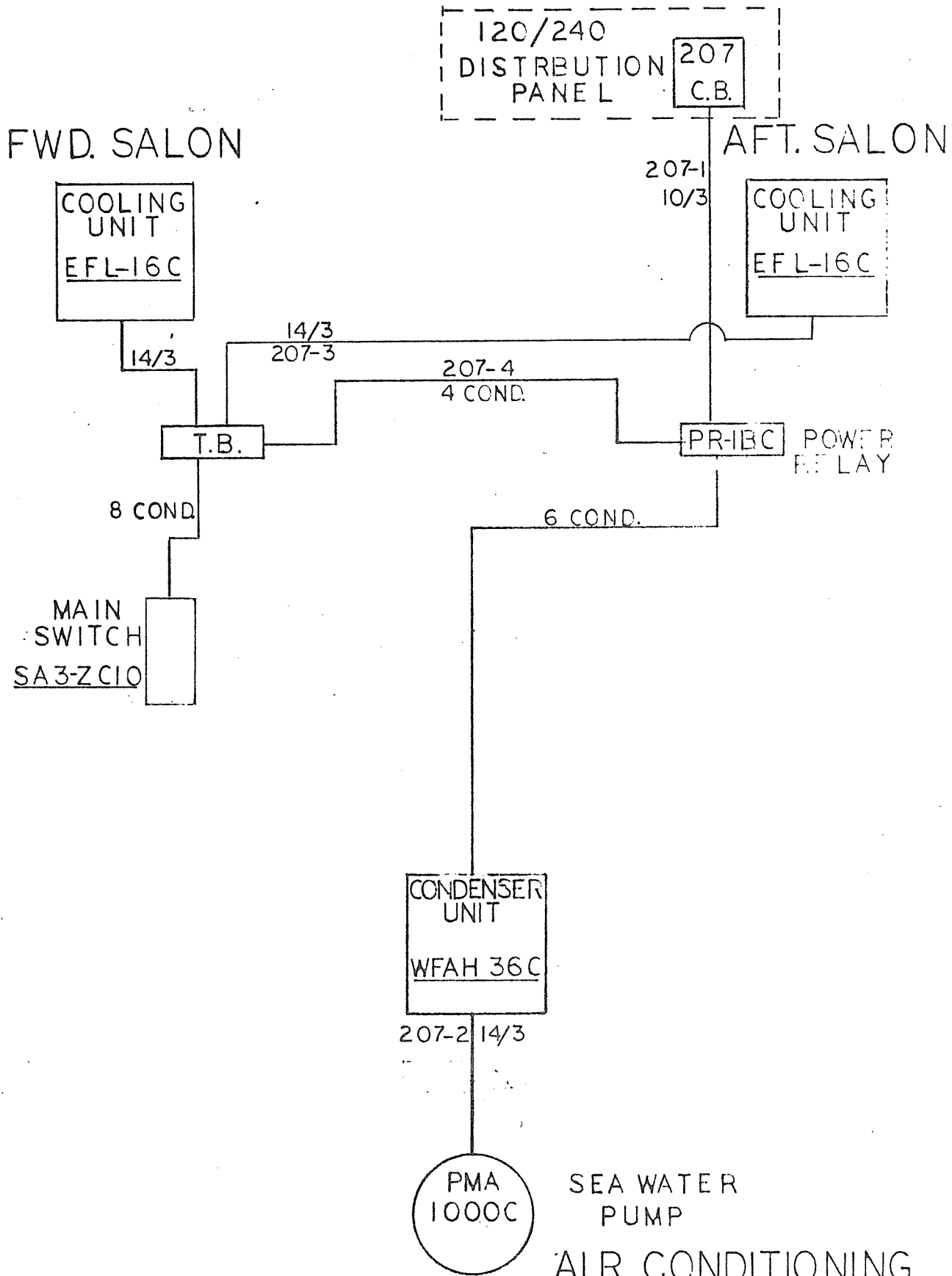

REV. A

585 AC10

AIR CONDITIONING
SALON SYSTEM
BLOCK DIAGRAM

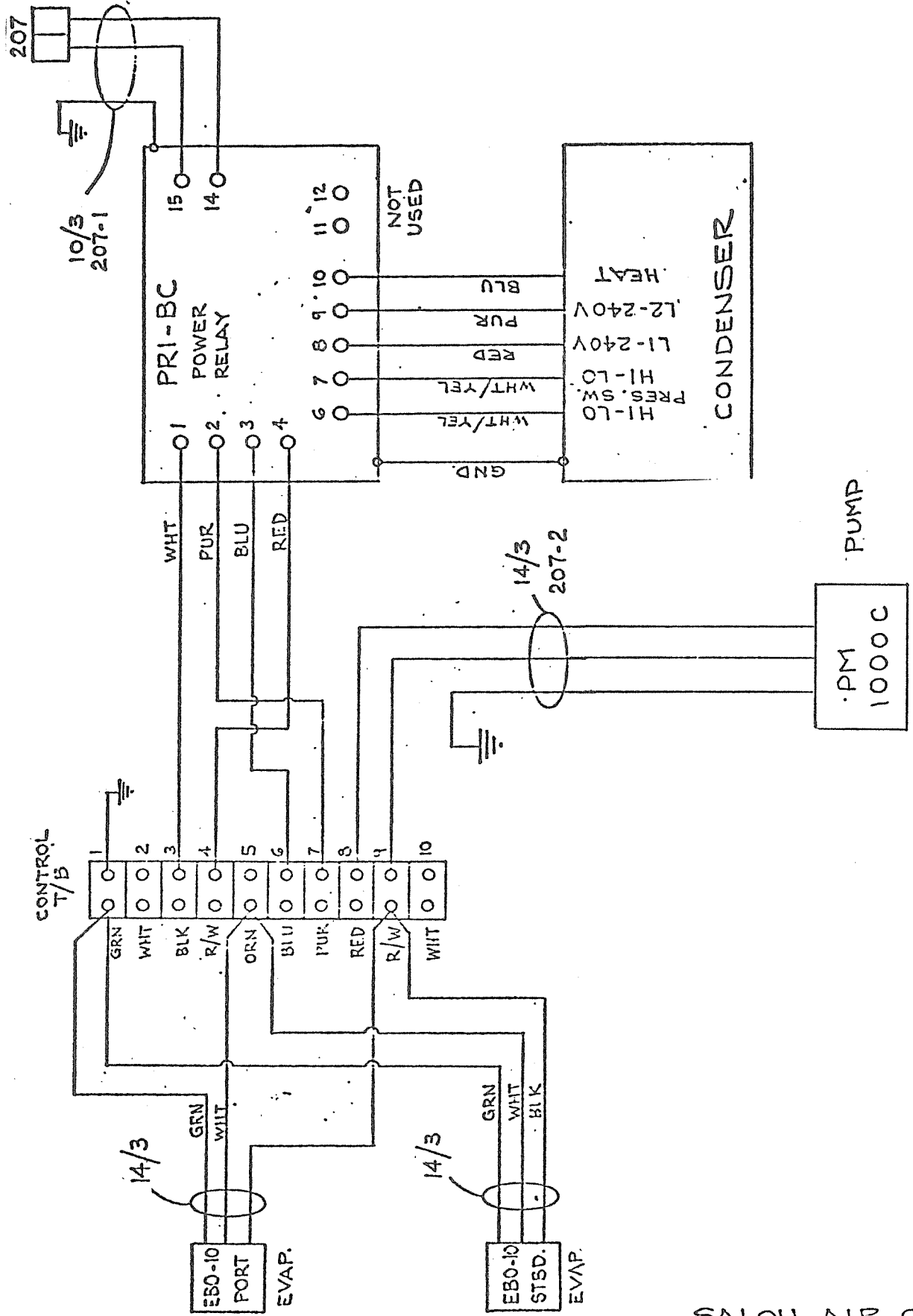

SALON AIR CONDITIONING WIRING DIAGRAM

STEREO L-PAD
(RADIO SHACK 40-979)

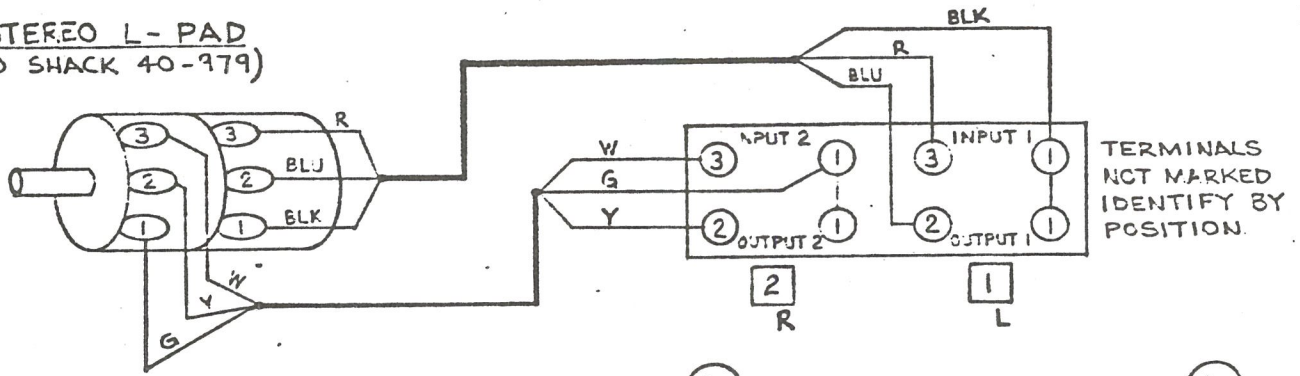

TERMINALS NOT MARKED IDENTIFY BY POSITION.

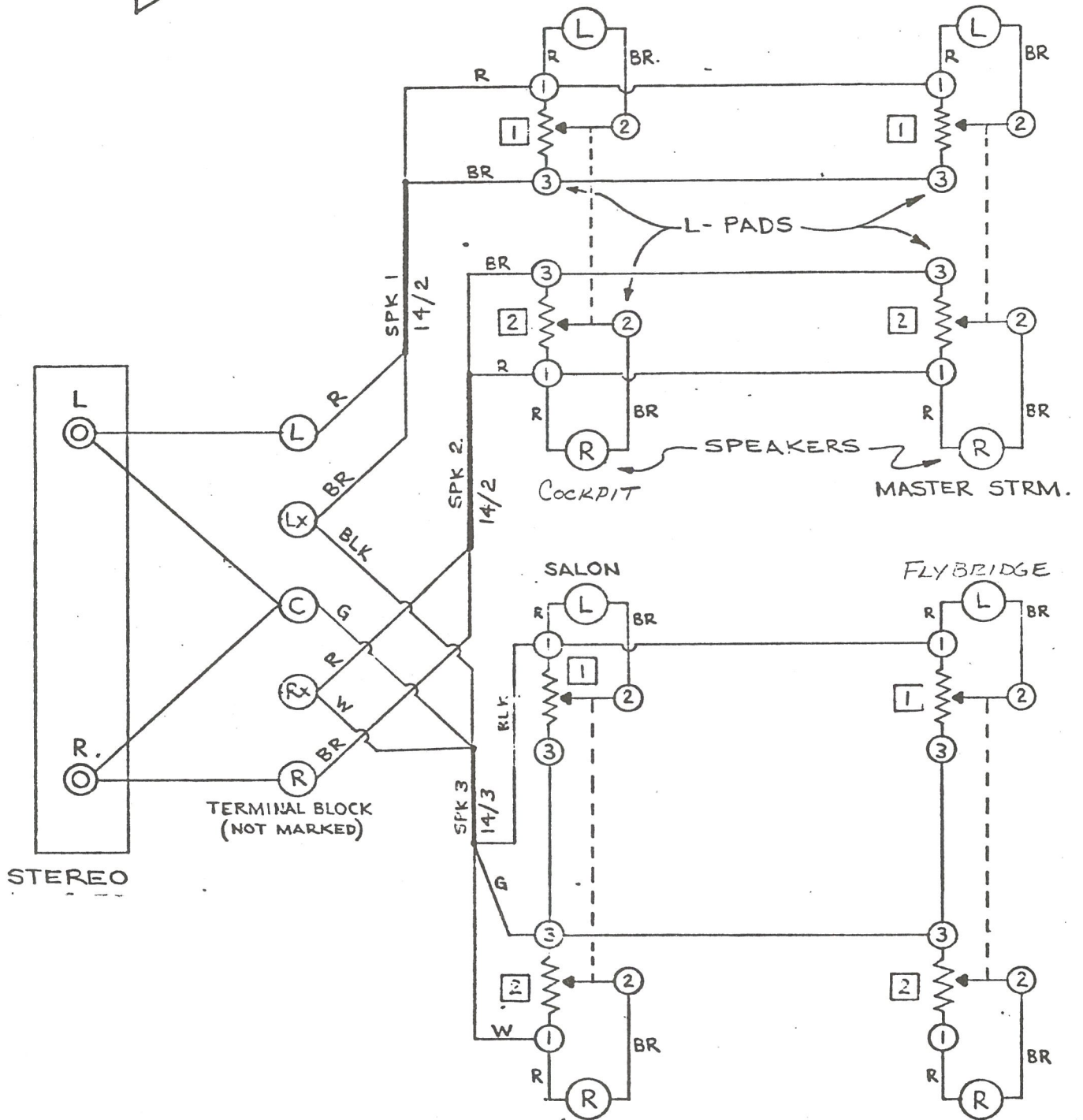

STEREO SYSTEM SPEAKER CIRCUITS