

**T-ZERO** PRO

POWER & INNOVATION

# LIGHTING TOWER X-ECO HYBRID - LITHIUM

Synthesis of power  
Savings and development



# T-ZERO<sup>PRO</sup>

## POWER & INNOVATION



REDUCE COSTS

REDUCE NOISE

REDUCE CO<sub>2</sub> EMISSIONS

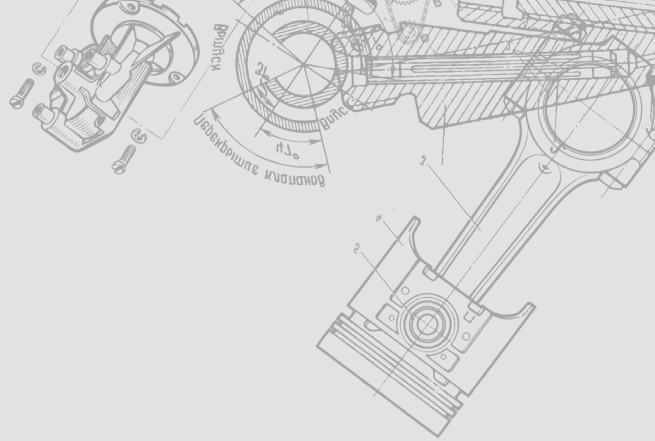

# LIGHTING TOWER X-ECO HYBRID - LITHIUM



Antiglare system



Can be transported in a small van



20 unit for truck

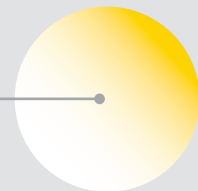

illuminated area 3000 sqm

### APPLICATIONS



Construction & work sites



Rural & hard to reach areas



Special events



Parking areas



Military applications



Gas, oil & mining operations



technical data	X-ECO Hybrid lithium
Illuminated area	3000 sqm
Batteries	1x 28,9 Vdc 185ah Lithium
Battery pack	25,9 Vdc 185ah Lithium
Running time from battery	11,30 h
Overall Running time	625 h
Engine	YANMAR 2TNV70
Dimensions mm	2540x1380x2500
Mast	hydraulic
Weight	1120 kg

**T-ZERO<sup>PRO</sup>**  
www.t-zero.com

Sales Dept. +39 0382 406 252  
info@trime.it

**TRIME GROUP**