

The antenna AD-18/CF-2512 is a "center-fed" type mobile VHF/UHF antenna for the frequency range from 20-512 MHz, mainly intended for use in heavy-duty mobile applications. The antenna is designed as dipole in both VHF and UHF bands and does not require any ground plane, so the electrical performance (GAIN and VSWR) of the antenna are always the same. This specific antenna design allows various types of mounting.

The antenna is composed of three main parts: antenna base, lower, and upper radiating element. Both radiating elements are made of composite materials that enable outstanding strength and roughness even in the hardest conditions of use. The antenna radiator is painted with military green (RAL-6014) two-component UV-resistant paint. Other colors and connectors are available on request.

The vehicle antenna base is made of aluminum and durable plastic materials, optionally with integrated GPS L1 or L1/L2. Big stainless steel spring absorbs the shocks and the vibrations, also, protects the antenna against impacts. The vehicle antenna base has NATO standard four mounting holes equally spaced on a 4.5" (114.3 mm) circle.

The mast antenna base is made of two stainless steel joints and a hard polyester tube with an outer diameter of 42.7 mm. The tube is equipped with special mounting console adapters which can be installed on the poles up to 60 mm in diameter.

ELECTRICAL SPECS.:	
Frequency range	20 - 512 MHz
Impedance	50 ohms
VSWR	< 3
Gain	See diagram
Polarization	Linear Vertical
Radiation Pattern	Omnidirectional
Maximum power	100 W CW
Connector	N female
ELECTRICAL SPECS - GPS:	
Frequency range	L1 1575.42 +/- 10 MHz or L1/L2 1575/1227 MHz
Impedance	50 ohms
VSWR	< 2
Polarization	RHC
Gain (LNA)	26 dB @ 5V / 20 dB @ 2.5V
Noise fig.	1.35 dB
Power supply	from 2.5 V DC (7 mA) to 5 V DC (16 mA)
Connector	SMA female
MECHANICAL SPECS:	
Design	Dipole (VHF) & Dipole (UHF)
Height (Option 1)	3200 mm
Height (Option 2)	3120 mm
Weight (Option 1)	6.85 kg
Weight (Option 2)	4.65 kg
Max. high voltage rating	16 kV
Wind rating	45 m/s (160 km/h)
Color	MIL Green
ENVIRONMENTAL SPECS:	
High Temperature - Storage	MIL-STD-810G; Method 501.5; Proc. I; +75 °C for 96h
High Temperature - Operating	MIL-STD-810G; Method 501.5; Proc. II; +65 °C for 16h
Low Temperature - Storage	MIL-STD-810G; Method 502.5; Proc. I; -55 °C for 96h
Low temperature - Operating	MIL-STD-810G; Method 502.5; Proc. II; -40 °C for 16h
Humidity	MIL-STD-810G; Method 507.5; 10 cycles of 24 h; 95%
Solar radiation	MIL-STD-810G; Method 505.5; Proc. I; 3 cycles
Rain	MIL-STD-810G; Method 506.5; Proc. III
Icing/Freezing Rain	MIL-STD-810G; Method 521.5
Sand and Dust	MIL-STD-810G; Method 510.5; Proc. I and II
Vibration	MIL-STD 810G, Method 514.6; Proc. I
Shock-Transit Drop	MIL-STD-810G, Method 516.6, Procedure IV
Contamination by Fluids	MIL-STD-810G, Method 504.1, Procedure II (Fuels, Hydraulic Oils and Lubricating Oils acc. to the Table 504.1-I.)
Oak-beam test	20 hits on 100 mm oak beam at speed 25 km/h
EMP Protection	MIL-STD 461E RS105



Option 2:
Mast base



Option 1:
Vehicle base



VERSIONS:

- AD-18/CF-2512-N*: VHF/UHF antenna with N female connector on vehicle base
- AD-18/CF-2512-G-N*: combined VHF/UHF (N female) and GPS L1 (SMA female) antenna
- AD-18/CF-2512-G2-N*: combined VHF/UHF (N female) and GPS L1/L2 (SMA female) antenna
- AD-18/CF-2512-M-N*: VHF/UHF antenna with N female connector on mast base

* N connector by default, others connectors are available on request: BNC or TNC female

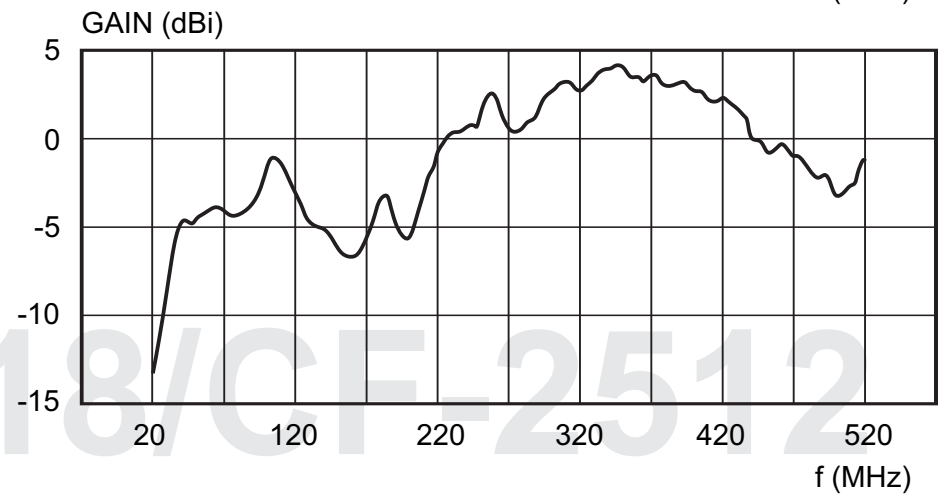
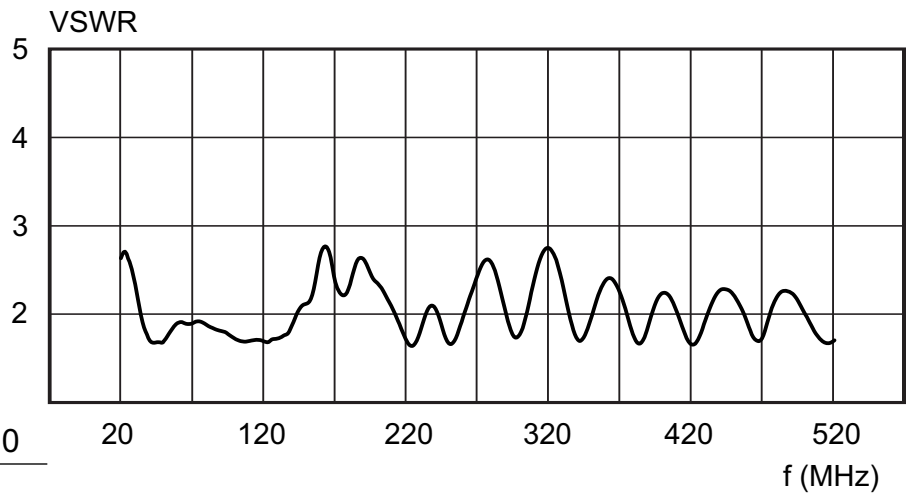
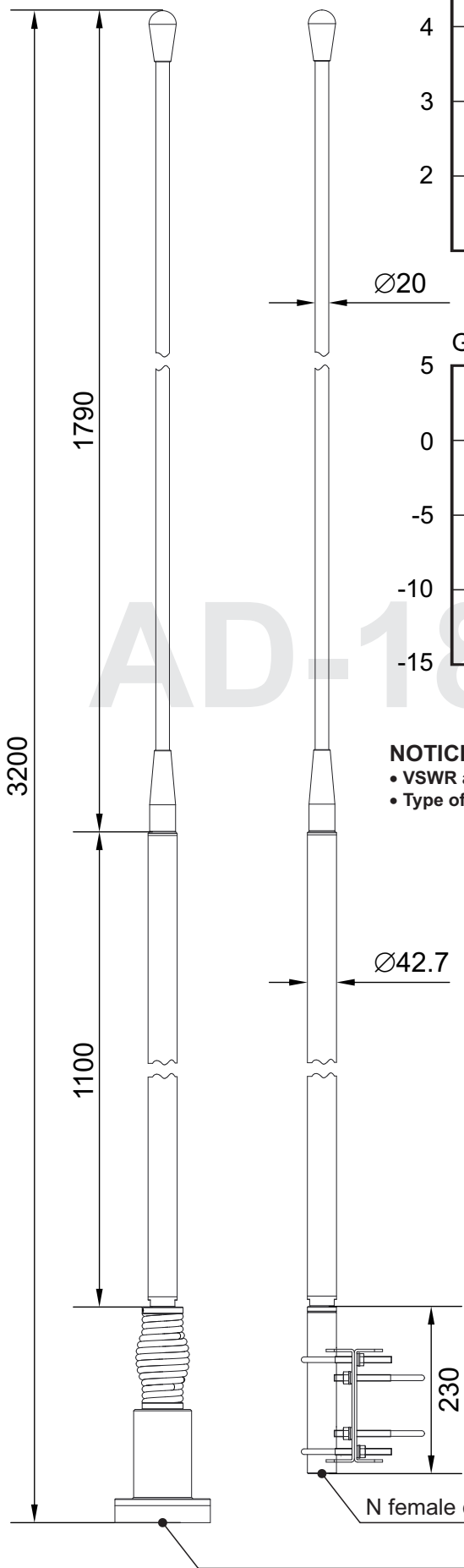

NOTICE:

- VSWR and GAIN data are provided with the antenna installed on a fiberglass without ground.
- Type of installation does not affect electrically characteristics of the antenna.

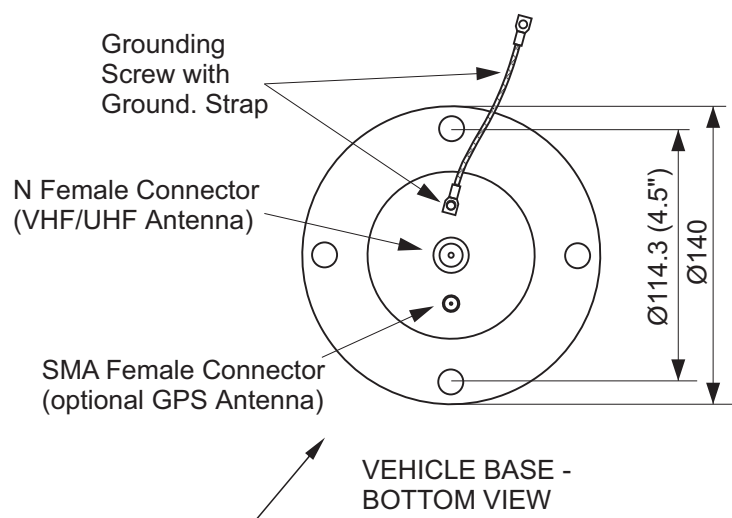

AUTHORIZED USA DISTRIBUTION BY:

Cyntony Corporation
 195 Follen Road
 Lexington, Massachusetts
 sales@cyntony.com
 781-430-0675

