

Model 410 Print and Apply Labeler

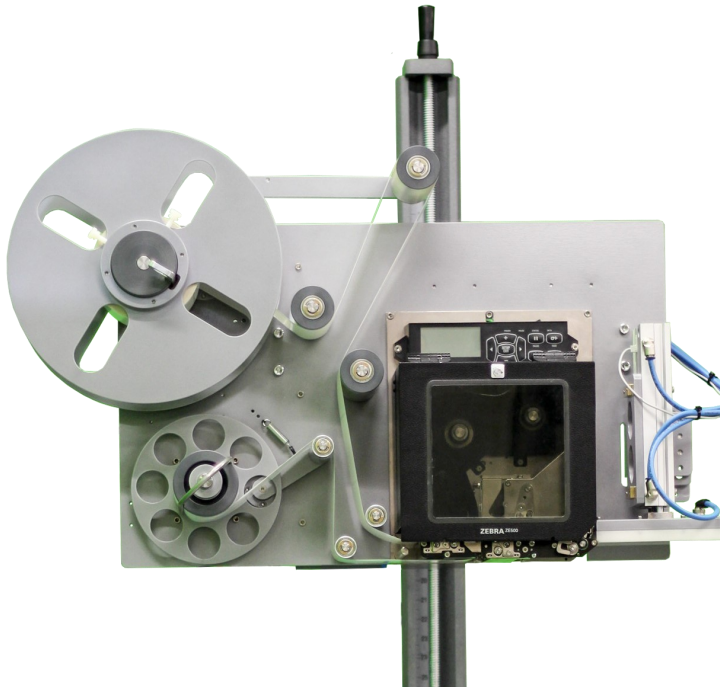

The Model 410 Print Apply labeler can be used to label products, cases, or pallets. This machine has a user-friendly touchpad operator interface. It also has a compact design which allows it to fit in small spaces. An optional control allows computer free operation on your shop floor.

FEATURES:

- Heavy duty compact design
- Touchpad operator interface for easy operation
- Accessible PLC for easy service
- 12" diameter label roll capacity
- 115 VAC electricity
- 60 psi air required
- Mount options
- Printer options
- Communication options

APPLICATION METHODS

- Tamp (standard)
- Smart tamp for random size boxes
- Blow on
- Tamp-blow
- Tilt/wipe-on
- Corner wrap
- Two panel

LABELPACK[®]

AUTOMATION

Model 410 Print & Apply Labeler

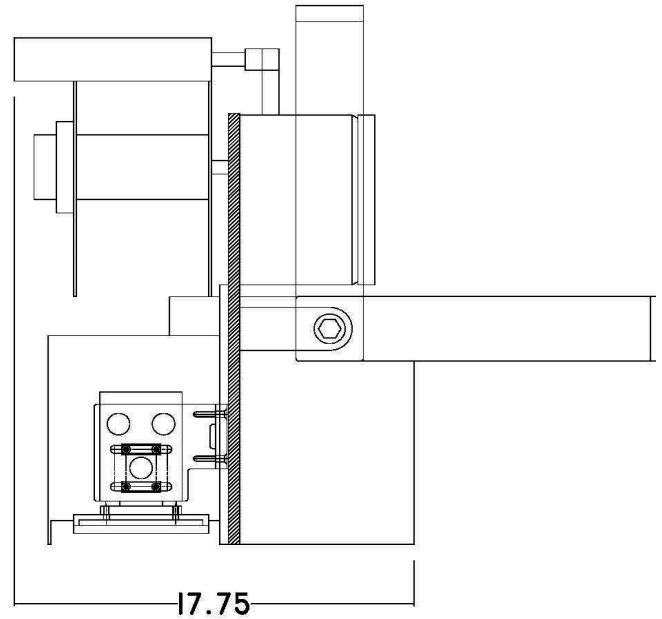
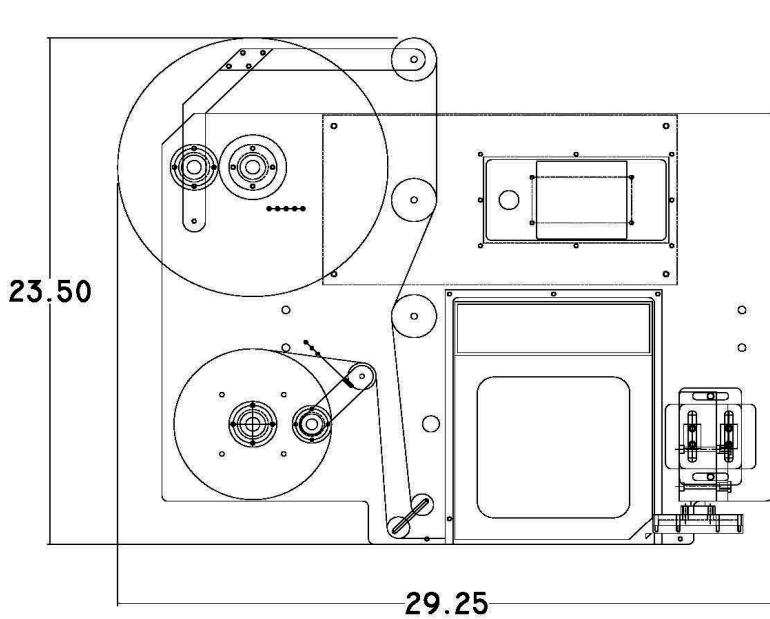

Printer Options:

- Zebra, Sato, Datamax, Avery
- 205, 300 or 600 dpi print resolutions
- Label web widths up to 7.6"
- Print speeds up to 16"/second
- Print with or without a ribbon
- Ribbon saver available
- RFID encoding

Other Options:

- 16" OD supply roll
- 6" core adapter
- Choice of various controls:
 - Panasonic (standard)
 - Allen Bradley
 - Siemens
 - Mitsubishi
 - Red Lion

Mount Options:

- Heavy duty stand
- Top or side mounted on conveyor
- Custom mounting configurations

Communication Options:

- Parallel
- Serial
- Ethernet
- Wireless
- USB
- CF card transfer