



Job: _____

Item No. _____

DESIGNED FOR HIGH VOLUME APPLICATIONS

25 Gallons per Hour – 7 Qt. Capacity

COMPLETE AUTO-FILL SYSTEM IN A SPACE SAVING DESIGN!

The **SaniServ**® model WB7110 Remote Refrigeration Auto-fill Frozen Beverage Freezer is designed to provide a high volume of frozen beverages through a continuous product source such as; “bag in the box” or pre-mixed product supply systems! The WB7110 remote refrigeration system is ideal for lowering costly indoor air conditioning operating costs by providing less heat build up while providing quieter operation! The space saving design of the WB7110 is a perfect solution to provide counter tops with frozen beverages!

SPACE SAVING

Small Footprint Design - SaniServ® offers frozen beverages in the smallest space saving equipment and design available! Owners and Operators can turn even the smallest of countertop space into a high profit center while enjoying lower indoor operating costs and providing the frozen beverages customers want!

EASY CLEANING AND OPERATION

Fewer Parts = Simplified Cleaning – SaniServ® equipment is designed and built with the fewer parts to be disassembled, cleaned and sanitized than any other machine in the industry.

HIGH RETURN ON INVESTMENT

Increased Profits – SaniServ® machines combine affordable efficiency with consistent product quality and fast quiet operation to insure customer satisfaction with high profit frozen beverages.

QUALITY DESIGN

Durability – SaniServ® machines are built to achieve long and dependable life through simplicity of design. Every machine is shipped standard with a stainless steel exterior, durable steel interior frame construction, heavy-duty components and consistency systems.

Model WB7110

Countertop

Frozen Beverage Machine For Use with Remote Condenser



Made in USA

We reserve the right to change specifications and products design without notice. Such revisions do not entitle the buyer to corresponding changes, improvements, additions or replacements for previously purchased equipment



MODEL WB7110

Counter Model Frozen Beverage/Cocktail Freezer For Use With Remote Condenser and Remote Fill System

These units may interface with existing beer and wine transfer systems by the addition of an additional regulator to further reduce the pressure of the normal system.

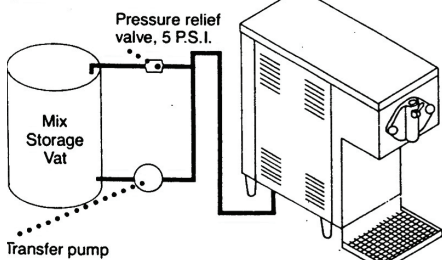

Note: This unit requires remote refrigeration system, not shown.

Minimum Wall Clearance
Both Sides and Back -
6 inches (152 mm)

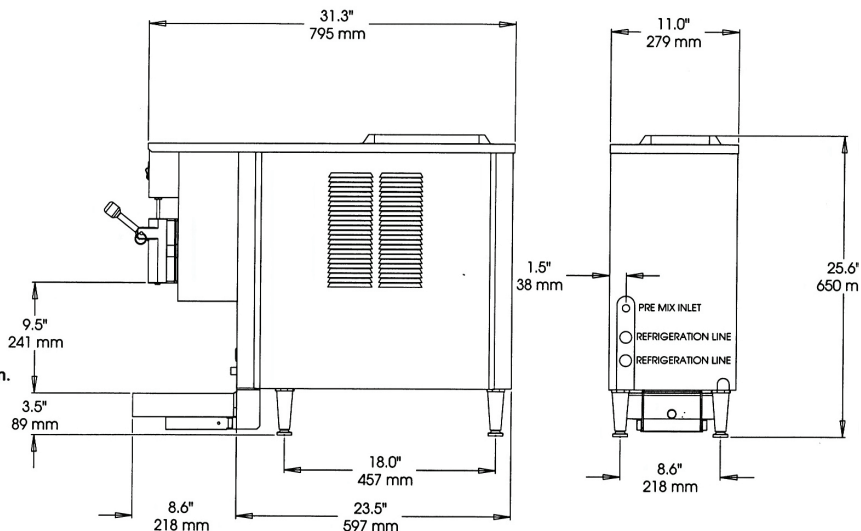

ELECTRICAL				WIDTH	HEIGHT	DEPTH	WEIGHT	VOLUME
VOLTS	Hz	Ph.	Amps	INCHES (MM)	INCHES (MM)	INCHES (MM)	LBS. (Kg)	CU FT. (cu. m.)
115	60	1	15	11 (279)	25.6 (650)	31.3 (795)	124 (56)	
Shipping Specifications				22.5 (572)	38 (965)	36.5 (927)	154 (70)	18 (.51)

Specifications:

Dasher Motor:
1/4 HP

Refrigerant Type:
R404A

Listings:
UL, cUL, NSF

Additional Equipment Required:
Requires a remote condensing unit (condenser & compressor) connected by two refrigeration lines and a remote fill system.

Required BTU/Hour:
Max 13,750 at 0 degrees F evaporator and 110 degrees F condensing.

Features:

Evaporator and Mix Reservoir Capacity:
7 Quarts (6.6 liters)

Dasher:
Heavy-Duty Stainless Steel with low friction scraper blades.

Solid-state Automatic Visual Mix Out Alert System

Warranty:

Parts 1 year
Evaporator 5 years

Options:

Tune Up Kit
Parts Tray
Drink Spinner
Machine Stand
Export Voltage