

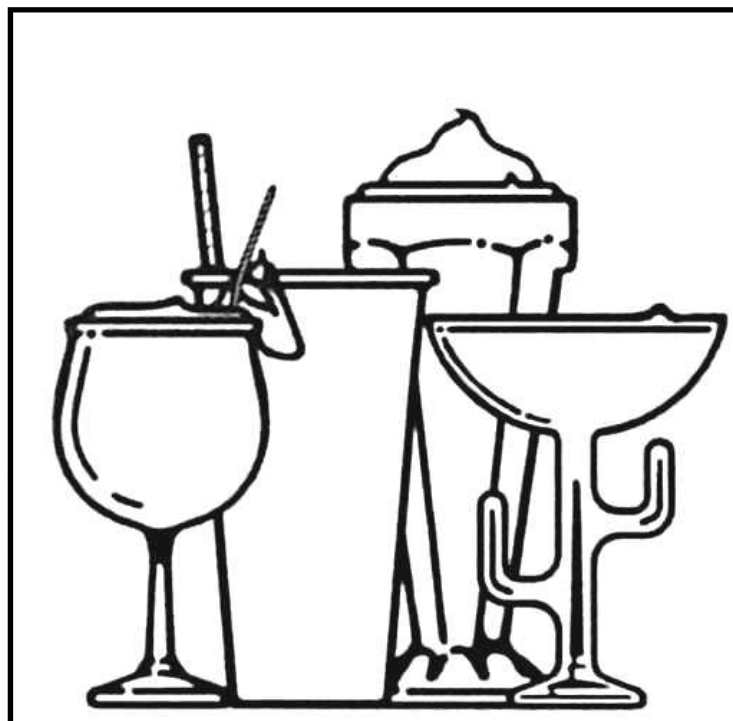

*“Reliability from the team that Serves the Best”*



108R Remote Frozen Beverage Dispenser

# Operation Manual

SaniServ P.O. Box 1089 Mooresville, Indiana 46158



**Distributor Name:** \_\_\_\_\_

**Address:** \_\_\_\_\_

**Phone:** \_\_\_\_\_

**Date of Installation:** \_\_\_\_\_

**Model Number:** \_\_\_\_\_

**Serial Number:** \_\_\_\_\_

**Installer/Service Technician:** \_\_\_\_\_

**SERVICE:** Always contact your SaniServ dealer or distributor for service questions or service agency referral. If your SaniServ dealer or distributor cannot satisfy your service requirements, he is authorized to contact the factory for resolution.

**Note:** It is the Owner's responsibility to maintain the Service Record located on the inside rear cover of this manual. An accurate record of service performed can greatly expedite troubleshooting of problems and significantly reduce repair costs.

**PARTS:** Always order parts from your SaniServ dealer or distributor. When ordering replacement parts, specify the part numbers, give the description of the part, the model number and the serial number of the machine.

**WARRANTY:** Remove the Check Test Start (CTS) form and fill it out in its entirety. Return the original (white) copy to SaniServ. The Dealer/Distributor retains the second (yellow) copy and the Owner/Operator retains the third (pink) copy.

The Manufacturer's Limited Warranty is printed on the reverse side of the Owner/Operator copy.

**IMPORTANT**

**TO VALIDATE THE WARRANTY, THE CTS FORM MUST BE COMPLETED AND RETURNED TO THE FACTORY WITHIN 30 DAYS OF INSTALLATION.**

**Note:** The Check Test Start function must be performed by a qualified technician.

## Contents

Introduction/Specifications .....	1
Installation .....	2
Leg Adjustment .....	2
Drip Tray Bracket .....	2
Air Circulation .....	2
Electrical Hook-Up Procedure .....	2
Refrigeration Installation.....	3
Autofill System Installation .....	4
Spigot Assembly .....	4
Disassembly and Cleaning .....	5
Emptying the Machine .....	5
Disassembly/Cleaning Procedure .....	5
Assembly and Lubrication .....	8
Sanitizing .....	9
Operation .....	10
Helpful Hints .....	11
Routine Maintenance .....	12
Consistency Adjustment .....	15
Troubleshooting .....	16
Thermostatic Expansion Valve (TXV) Adjustment Procedure .....	17
Diagram A .....	18
Diagram B .....	18
Diagram C .....	18

## Illustrations

Fig.1 Leg Adjustment .....	2
Fig.2 Drip Tray Bracket Installation .....	2
Fig.3 Control Switch .....	5
Fig.6 Front Plate Assembly .....	6
Fig.8 Dasher Assembly .....	6
Fig.9 Dasher Lubrication .....	8
Fig.10 Dasher Assembly .....	8
Fig.11 Carb Tube .....	7
Fig.12 Front Plate Assembly .....	9
Fig.15 Control Switch .....	10
Fig.18 Consistency Adjustment.....	15

# Introduction

This manual provides a general system description of the **SaniServ** 108R Frozen Beverage Dispenser . It has been prepared to assist in the training of personnel on the proper **installation**, operation, and maintenance of the dispenser. This unit is a component system having both remote product fill and a **remote** refrigeration system. Please read and fully understand the instructions in this manual before attempting to install, **operate** or perform routine maintenance on the machine.

## 108R DISPENSING HEAD

### IMPORTANT

**ALWAYS CHECK THE ELECTRICAL SPECIFICATIONS ON THE DATA PLATE OF THE INDIVIDUAL UNIT DATA PLATE SPECIFICATIONS WILL ALWAYS SUPERSEDE THE INFORMATION IN THIS MANUAL.**

### Specifications/Dimensions

	WIDTH INCHES (mm)	HEIGHT INCHES (mm)	DEPTH INCHES (mm)	VOLTS/HZ/PHASE	AMPS	WEIGHT LBS (kg)
MACHINE	16.4 (417)	36.8 (935)	30.3 (770)	115/60/1	15	210 (95)

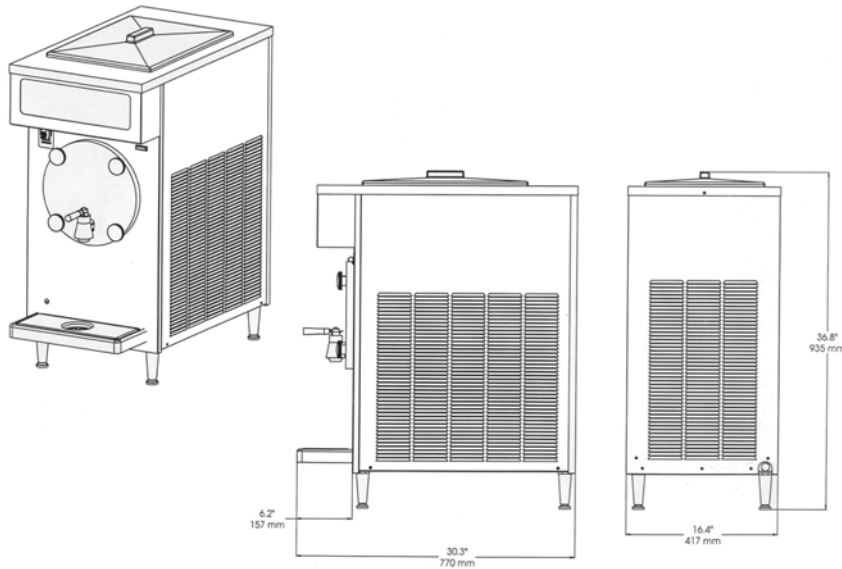

**Evaporator and Mix Reservoir**  
**Capacity:** 26 Quarts (24.6 liters)

**Construction:** Welded Steel Support, Stainless Steel Exterior, Legs Standard.

**Dasher:** Heavy-Duty Stainless Steel with low friction scraper blades.

**Dasher and Compressor Motors:**  
 1/2 HP Dasher      3/4 HP Compressor

**Shipping Volume:** 18.06 Ft<sup>3</sup> (0.51 m<sup>3</sup>)

**Refrigerant Type:** R404A

# Installation

## Leg Adjustment

Position the dispensing head and condensing unit in the appropriate locations. Level both units by turning the adjustment on each leg clockwise or counterclockwise (Fig. 1). The dispensing head **MUST** be level to operate properly and must be operated with the legs installed.

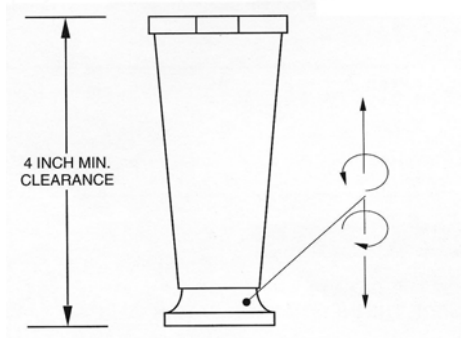

Fig. 1  
Leg Adjustment

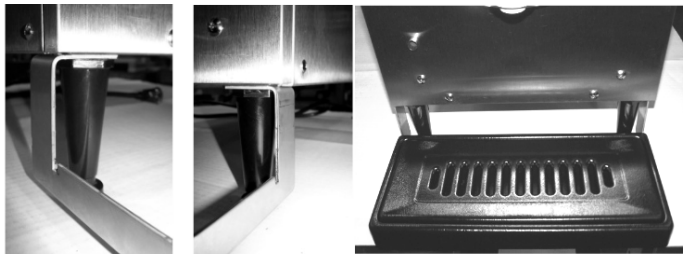

Fig. 2  
Drip Tray Bracket Installation

## Drip Tray Bracket Installation

1. Install the legs onto the bottom of the machine.
2. Leave a 1/4" gap in the front legs.
3. Slide right and left drip tray support brackets onto leg studs with flanges toward center of machine.
4. Tighten legs around supports and level the machine.
5. Place drip tray onto supports and place insert into drip tray.

## Air Circulation

A minimum clearance of 6" around the dispensing head and 10" around the condensing unit must be maintained for adequate ventilation.

**AIR CIRCULATION AROUND CONDENSING UNIT MUST ENABLE A FRESH SUPPLY OF AMBIENT AIR, NOT A RECIRCULATION OF THE AIR BEING EXHAUSTED FROM THE UNIT.**

### IMPORTANT

**AIR CIRCULATION AROUND CONDENSER UNIT MUST ENABLE A FRESH SUPPLY OF AMBIENT AIR., NOT A RECIRCULATION OF THE AIR BEING EXHAUSTED FROM THE**

### WARNING

#### Electrical Hook-Up Procedure

Electrical specifications are located on the data plate (on rear panel of dispensing head and front panel of condensing unit). Consult local authorities for information regarding electrical codes in the area.

# Refrigeration Installation

Refrigeration specifications are located on the data plate at the rear of the dispensing head and the front of the condensing unit. Use standard precautions as with any other HFC refrigerant. **Note:** This unit uses a HFC refrigerant, HP-62 (R404A). Do not use any other refrigerant. **UNDER NO CIRCUMSTANCES ARE HP-62 (R-404A) AND R-502 TO BE MIXED IN THE SAME SYSTEM.**

## IMPORTANT

**THE INSTALLATION OF THE DISPENSING HEAD AND CONDENSING UNIT MUST BE PERFORMED BY QUALIFIED AND CERTIFIED REFRIGERATION PERSONNEL ONLY.**

### 1. Installing Refrigeration Copper Lines:

- a. Route the refrigeration copper lines from the dispensing head to the condensing unit.
  - b. Solder the copper tubes into the supplied quick connect/disconnect fittings.
  - c. Install access fittings on each of the lines (one for the liquid and one for the suction line). If the suction line has an overall run length of under 50 feet, use 5/8" copper. If the run length is over 50 feet, use 3/4" copper. Regarding the liquid line, 3/8" copper is sufficient for all lengths of the run. In all cases keep the total line length as short as possible to ensure maximum system performance. **NOTE: Failure to install access fittings in the refrigerant lines will result in the necessity of recovering the holding charge before pulling a vacuum in the lines.**
  - d. Insulate the suction line with **rubatex** insulation. Minimum thickness is 1/4" wall, use a thicker wall if feasible.
  - e. Before installing the lines to the dispensing head and condensing unit, the refrigeration lines must be evacuated, then leak checked, then a suitable refrigerant charge added before connection to either the dispense head or condensing unit. **NOTE: A holding charge has been placed in both the dispensing head (0.5# of HP-62) and the condensing unit (1.5# of HP-62).**
2. After ensuring the refrigeration lines have no leaks, the lines are ready to be installed to the dispense head and the condensing unit. Care should be taken to prevent damage to the threads on the quick connect fittings. Tighten fully and ensure there is no leak at the thread connections. The unit is now ready to start up provided the necessary electrical and **autofill** line connections have been made.

3. Turn power on to the dispense head. Fill the dispense head with product. Set the freeze and dasher switch "ON". With the refrigeration gauges at the dispense head suction access port, slowly add refrigerant to the unit until suction pressure is above 20 **psig**. Delete this step if pressure is above 20 **psig**. Turn power on to the condensing unit. The compressor should start. If necessary, add refrigerant slowly to keep the compressor running. Sufficient refrigerant will need to be in the system to prevent cycling on the pressure switch.
4. Return to the condensing unit and install gauges at the suction access port and on the high side at the receiver tank. Make a note of the system's high and low side pressures. Also make a note of the unit's superheat. **NOTE: This unit is equipped with a **thermostatic expansion valve (TXV)** and is preset to the proper setting at the factory. The suction pressure at shut-off will range between 27-33 PSIG. The superheat at shut-off will be 1 5°-20° F. No field adjustment is required. (For additional TXV information, see page 18.)**
5. This unit works on a pump down cycle with the torque switch cycling the liquid line solenoid valve. This allows the compressor to cycle as needed on the low pressure switch. The settings are as follows. Cut in is at 20 psig and cut out is at 10 psig. Check and verify these pressures and adjust as necessary.
6. The high pressure switch is a safety switch only. This is to prevent compressor damage in the event of abnormally high head pressures. The setting for this switch is 400 psig. **Make a note of the suction pressure at the dispense head at shut-off to verify cut-in and cut-out of the pressure switch.**

## IMPORTANT

**TO PROPERLY SET REFRIGERANT PRESSURES AND CONTROLS, THE UNIT MUST HAVE PRODUCT IN THE BARREL. DO NOT ATTEMPT TO SET THE SYSTEM PRESSURES WITHOUT A LOAD ON THE SYSTEM.**

## IMPORTANT

**REFRIGERATION INSTRUCTIONS LISTED IN THIS MANUAL ARE SPECIFIC FOR THE INSTALLATION AND OPERATION OF ONE DISPENSING HEAD AND ONE CONDENSING UNIT. PRESSURES AND SPECIFICATIONS DO NOT APPLY TO MULTIPLE INSTALLATIONS.**

## Autofill System Installation

1. Connect the **premix** line from the remote fill system to the 3/8" barbed fitting located at the rear of the remote dispensing head. **Oetiker®** clamps are required to contain the working pressures of the system. Pressurize the line.
2. Activate the **autofill** system by pressing the fill switch located on the front panel of the dispensing head
3. Purge the line by allowing the mix pan to fill until the **system** probes close the fill switch solenoid valve.

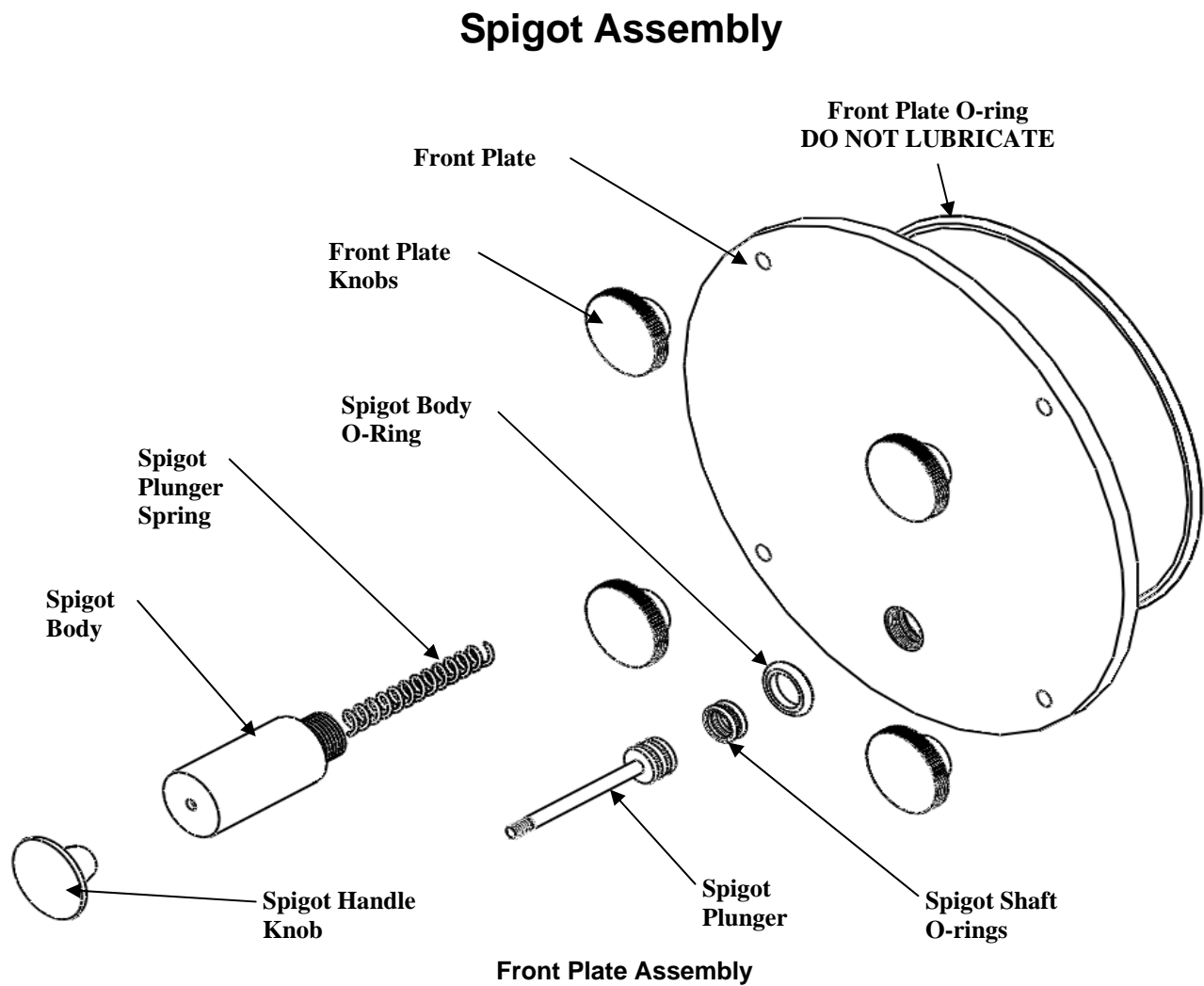



## DISASSEMBLY AND CLEANING

THIS UNIT DOES NOT COME **PRESANITIZED** FROM THE FACTORY. BEFORE SERVING PRODUCT, THE DISPENSER MUST BE DISASSEMBLED, CLEANED, LUBRICATED, AND SANITIZED. THESE INSTRUCTIONS ARE GENERAL GUIDELINES. CLEANING AND SANITIZING PROCEDURES MUST CONFORM TO LOCAL HEALTH AGENCY REQUIREMENTS (CONSULT YOUR LOCAL HEALTH AGENCY). CLEAN AND SANITIZE DAILY.

### CAUTION

DO NOT INSERT ANY OBJECTS OR TOOLS INTO THE MIX INLET HOLE OR FRONT PLATE DISPENSING HOLE WHILE THE MACHINE IS RUNNING. DAMAGE TO THE MACHINE OR PERSONAL INJURY MAY RESULT.

#### Emptying the Machine

Prior to the disassembly and cleaning of parts, the machine must be emptied of product. Use the following procedures (Steps 1 through 3). If this is first time operation, disregard these steps.

1. Set the freeze switch (Fig. 3) and fill switch to the "OFF" position and set the dasher switch to the "ON".
2. Dispense all product from the freezing cylinder by turning on the spigot handle to empty the machine.
3. Set all switches to "OFF". Close the spigot handle before proceeding to cleaning.

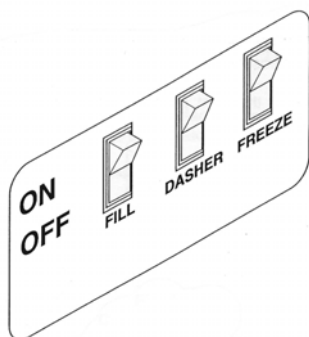

Fig. 3  
Control Switch

#### Disassembly/Cleaning Procedure

1. Remove the mix pan cover .
2. Fill the machine with warm (100°-120° F.) water and set **only** the **dasher switch** to the "ON" position.

### CAUTION

DO NOT USE HOT WATER, THIS MAY  
DAMAGE THE MACHINE

3. Let the machine agitate briefly and drain the water by opening the spigot handle. After the machine is empty, set the control switches to "OFF". Repeat the above procedure as necessary to ensure all product is removed from the machine.

4. Using a brand name anti-bacterial liquid hand dish-washing detergent, make a suitable cleaning solution by adding one (1) to two (2) ounces per gallon of warm water between 100° and 120° F. Fill the machine with the warm detergent and water solution. **DO NOT** use an abrasive detergent on any part of the dispenser.
5. After ensuring **ALL** switches are set to "**OFF**" position, thoroughly clean the interior of the mix pan and the tubes to the freezing cylinder<sup>^</sup> using the tube brush provided.
6. Set the dasher switch to the "**ON**" position and agitate for approximately 1-2 minutes and then drain the solution by opening the spigot handle. When the machine is empty, set the dasher switch to "**OFF**" .
7. Remove the front plate by turning the black plastic knobs in a counterclockwise direction. Remove the spigot.

8. Remove the dasher assembly (Fig. 8) from the freezing cylinder being careful not to damage the scraper blades. Now, disassemble the dasher in the following manner:

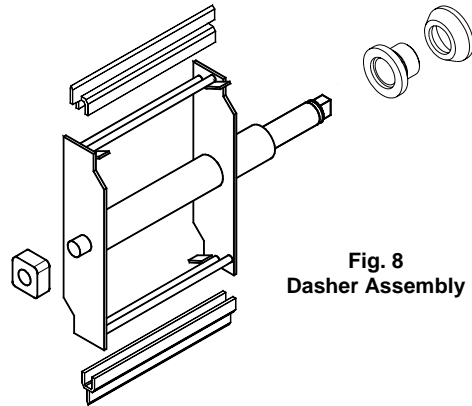
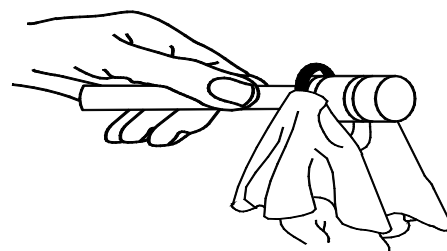

**Fig. 8**  
**Dasher Assembly**

- a. Remove dasher assembly.
- b. Remove and disassemble the two piece rear seal.
- c. Remove the front bearing..
- d. Remove the o-ring from the end of the dasher
- e. Remove the blades from the dasher assembly by first rotating the blade upward and then unsnapping one end from the support rod.



**Fig. 6**  
**Front Plate Assembly**



**O-ring Removal**

9. Remove the drip tray, drip tray insert.
10. Place all parts in a three partition sink:
  - a. One partition containing one (1) to two (2) ounces of a brand name antibacterial liquid hand dishwashing detergent per gallon of warm water between 100° and 120° F.
  - b. One partition containing warm rinse water.
  - c. One partition containing sanitizing rinse consisting of 175-200 parts per million (P.P.M) chlorine residual. Consult the local health authority for local code requirements.
11. Use the small diameter brush to clean all holes and ports in the parts. **DO NOT** use an abrasive detergent on any part of the machine.
12. After thoroughly washing the parts in the detergent solution, rinse them in the rinse water. Place the parts in the sanitizing solution for five (5) minutes and then air dry to prepare for assembly and lubrication. **DO NOT** wipe dry.

- 14 Install the o-rings on the carburetor assembly (Fig. 11). Apply lubricant sparingly over the o-ring. Place the carburetor tube in the bottom of the mix pan for sanitizing. **Lubricant MUST NOT BLOCK the inlet hole on the carburetor tube.**

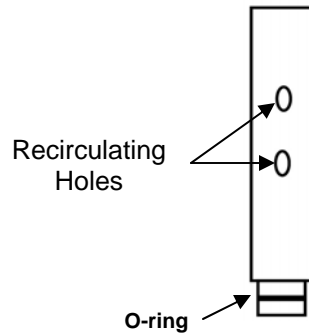

**Fig. 11**  
**Carburetor Tube Assembly**

### WARNING

**WHEN CLEANING THE MACHINE, DO NOT ALLOW EXCESSIVE AMOUNTS OF WATER AROUND ELECTRICALLY OPERATED COMPONENTS OF THE MACHINE. ELECTRICAL SHOCK OR DAMAGE TO THE MACHINE MAY RESULT.**

13. The remainder of the unit including the mix pan and freezing cylinder must be cleaned in place using the mild detergent solution. Clean the exterior with a damp cloth. If soil is not readily removed, use the mild detergent solution or other commercially available surface cleansers to thoroughly clean the exterior of the machine. Be certain to remove any residual soap or cleanser film with a clean, damp cloth. **DO NOT** use an abrasive cleaner on exterior panels.

Insert Carb  
Tube here

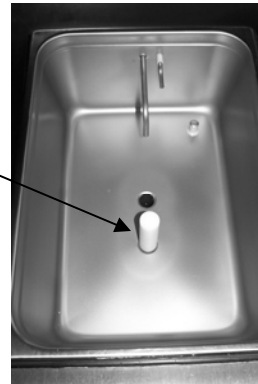

## Assembly & Lubrication

Use only food approved lubricants. Sani-gel is recommended and is available from your SaniServ distributor. Lubrication must be performed daily.

### CAUTION

#### WEAR SANITARY GLOVES FOR THE ASSEMBLY AND LUBRICATION PROCESS

1. Lubricate and assemble the dasher assembly in the following manner:
  - a. Apply a 1/4" bead of lubricant to the shoulder of the dasher where the white plastic portion of the assembled rear seal contacts the shaft (Fig. 9).
  - b. Lubricate the front dasher support as shown.
  - c. Assemble and install the rear seal with the rubber portion toward the rear of the dasher (Fig. 9). **DO NOT LUBRICATE THE REAR OF THE SEAL (RUBBER PORTION).**
  - d. Install the o-ring on the rear of the dasher shaft (Fig. 10).
  - e. Install the scraper blade onto the dasher (Fig. 10).
  - f. Insert the dasher assembly into the freezing cylinder as far as possible being careful not to damage the scraper blades. Damage will occur to the scraper blades and the dispenser will not operate properly if the scraper blades are installed facing in a clockwise direction.

2. While maintaining force against the dasher, rotate it slowly until the tongue of the dasher engages the groove in the drive system at the rear of the cylinder. The outer most portion of the dasher should be recessed approximately 1/4" to 3/8" inside the freezing cylinder. No part of the dasher should extend outside the cylinder. Scraper blades should be visible, extending approximately 1/8" beyond the dasher. **Be sure to install the front bearing as shown in Fig. 10.**

3. Lubricate and assemble the front plate assembly in the following manner:
  - a. Install the two o-rings on the spigot plunger by rolling them onto the plunger. Seat the o-rings in the grooves. Be certain that they are not twisted. Smooth the lubricant into the grooves and over the sides of the plunger assembly (Fig. 11).

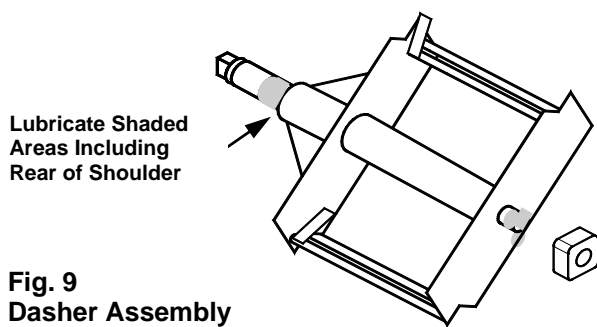

Fig. 9  
Dasher Assembly

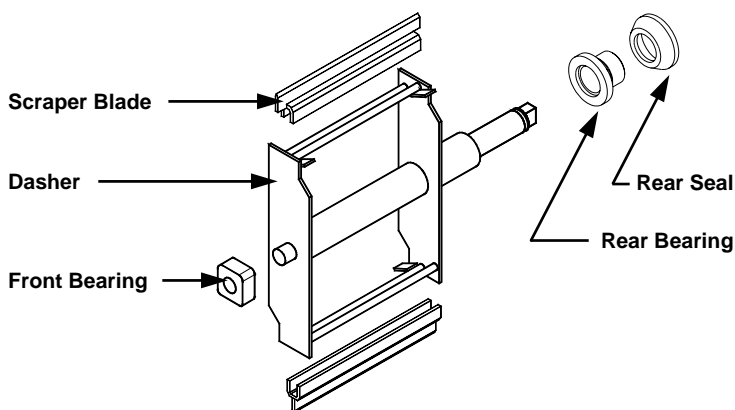

Fig. 10

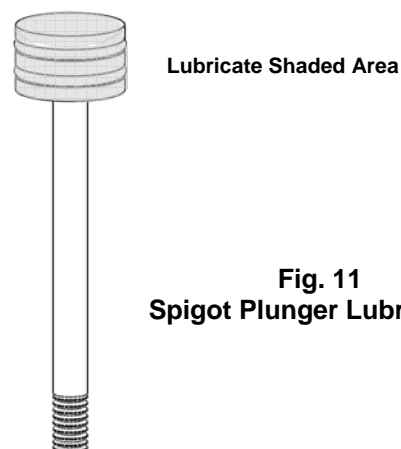

Fig. 11  
Spigot Plunger Lubrication

- b. Slide the Spigot Spring onto the Spigot plunger.
- c. Insert the lubricated Spigot Plunger and Spring into the Spigot Body (Fig. 12), making certain that the spigot plunger shaft is coming out the front of the Spigot Body.
- d. Screw on the Spigot Handle Knob onto the Spigot Plunger Shaft on the front of the Spigot Body.
- e. Place Spigot Body O-ring (do not lubricate) onto Spigot Body (Fig. 13), and screw the Spigot body onto the Front Plate.
- f. Install the front plate o-ring (do not lubricate).

**DO NOT LUBRICATE THE FRONT PLATE O-RING**

- g. Secure the front plate assembly with the four plastic knobs. Simultaneously, turn the knobs in a clockwise direction. Tighten the knobs evenly. **DO NOT** tighten one knob all the way down and then the other. Doing so may result in front plate breakage. Only moderate force is required. **DO NOT** over tighten. Close the spigot plunger.

4. Install the drip tray and drip tray insert .
5. Proceed directly to the "**Sanitizing**" section of this manual.

## Sanitizing

**PRIOR TO OPERATION, THE MACHINE MUST BE SANITIZED. THE UNIT MUST HAVE ALREADY BEEN CLEANED AND LUBRICATED. (NOTE: SANITIZE IMMEDIATELY BEFORE USAGE, NOT SEVERAL HOURS BEFORE OR THE PREVIOUS EVENING). CLEAN AND SANITIZE DAILY.**

### WARNING

**ALWAYS WEAR PROTECTIVE GLOVES AND GLASSES WITH SIDE SHIELDS WHEN WORKING WITH CLEANERS, DETERGENTS, AND SANITIZERS. ALWAYS READ AND UNDERSTAND THE MATERIAL SAFETY DATA SHEETS.**

1. Before starting the sanitizing procedure, wash hands with a suitable antibacterial soap.
2. Prepare approximately two (2) gallons of a warm sanitizing solution equivalent to 200 parts per million (P.P.M.) chlorine residual or as required by your local health agency.
3. Fill the freezing cylinder and mix pan with sanitizing solution.
4. Set the dasher switch to the "ON" position and allow the dasher to agitate for approximately two minutes. **DO NOT** set the freeze switch to "ON".
5. Open the spigot plunger and dispense all sanitizing solution from the machine.

### WARNING

**DO NOT INSERT ANY OBJECTS OR OTHER TOOLS INTO THE MIX INLET HOLE OR THE FRONT PLATE DISPENSING HOLE WHILE THE UNIT IS RUNNING. DAMAGE TO THE MACHINE OR PERSONAL INJURY MAY RESULT.**

6. Set the dasher switch to the "OFF" position. Proceed directly to the "**Operation**" section of this manual.

**DO NOT RINSE OUT THE MACHINE**

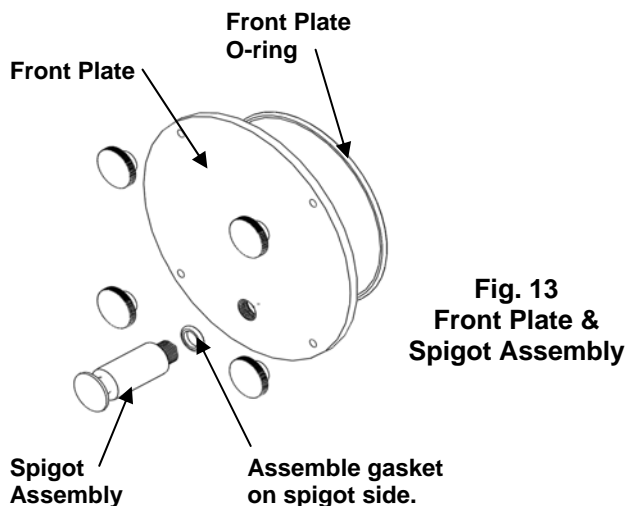
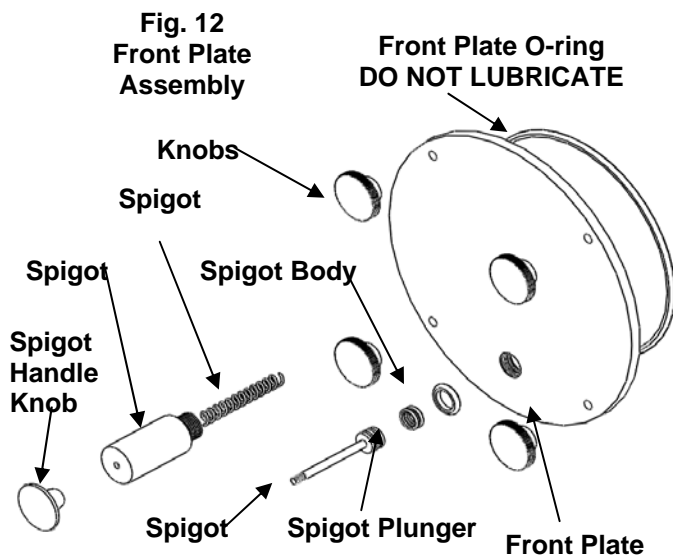

**Fig. 13  
Front Plate &  
Spigot Assembly**

## Operation

Always start with a cleaned and sanitized dispenser as per previous instructions. Use only fresh mix when charging the units. Adherence to these instructions is critical to the maximum operating efficiency of the machine.

1. Turn on the premix supply system to the unit.
2. Set the fill switch (Fig. 15) to the "ON" position.

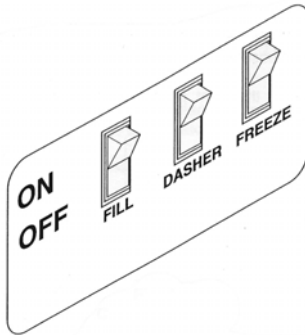

Fig. 15  
Control Switch

3. Simultaneously, open the spigot and dispense enough of the product to purge the system of sanitizing solution (approximately 16 ounces). Close the spigot plunger and fill the freezing chamber. When the mix pan probes are satisfied, the "**MIX OUT**" light goes off.
4. Set the dasher and refrigeration switches to the "ON" position. Both the dasher and compressor will start. Note: Dasher switch must be set to "ON" first. A light clicking noise may be heard as the dasher turns until the product in the freezing cylinder freezes.
5. Allow the compressor to cycle 3-4 times dispensing a sample of the product after each cycle to check for desired consistency. If the machine is not dispensing the product at the desired consistency after four full cycles, refer to the Consistency Adjustment section of this manual. Initial pull-down time is 8-10 minutes, but may vary due to product and ambient conditions.
6. Replace the side panel when the desired consistency is obtained.

## Helpful Hints

### Closed Hours/Shut-Down

If the machine is turned off during closed hours, follow these steps when resuming operation:

**NOTE: NEVER POUR FROZEN PRODUCT INTO THE MIX PAN. LET IT MELT FIRST.**

1. Set the dasher switch to the "ON" position for one to two minutes.
2. Dispense two quarts of product and pour it back into the mix pan. This acts as a mixing process to eliminate any overnight separation.
3. Set all switches to the "ON" position and resume operation.

### Drip Tray & Drip Tray Insert

These parts should be removed daily and cleaned to remove residue.

### Filling

Always fill the machine at the start of each day.

### Front Plate

This component is the plastic device from which the product is dispensed. It is designed and made for strength and durability. However, through improper use, it can be damaged. Use the following information for proper care.

- Do not lubricate the large o-ring on the rear of the front plate. If lubricated, it will not seal properly and product will leak.
- Do not over tighten the knobs.
- Always tighten front plate knobs evenly. Do not attempt to turn one knob all the way down and then the other. This will bind the front plate and result in breakage.
- Improper installation of the dasher front support can cause breakage. The dasher front support must be properly seated in the dasher before installing the front plate. If improperly installed, subsequent tightening of the knobs will break the front plate.
- Do not attempt to wash the front plate or any other machine components in a dishwasher.

## Routine Maintenance

### WARNING

**DISCONNECT THE MACHINE FROM ITS POWER SOURCE BEFORE PERSONAL PERFORMING ANY MAINTENANCE. INJURY OR DAMAGE TO THE MACHINE COULD RESULT.**

**DAILY:** Inspect the machine for signs of product leaks past seals and gaskets. If proper assembly does not stop leaks around gaskets or seals, check for improper lubrication, worn or damaged parts. Replace parts as needed.

**DAILY:** Always clean and sanitize your machine on a daily basis.

**PERIODICALLY:** Inspect the scraper blades to see that they are straight and sharp. If worn, damaged or warped, the blades will not scrape the cylinder wall correctly and freezing capacity will be reduced.

**PERIODICALLY:** A drip tube exits the front of the machine and drains into the drip tray. Whenever any residue appears in this drip tray, clean the drip tube assembly and the tray beneath the rear of the freezing cylinder. Removal of the left side panel exposes the screws which mount the rear seal leakage collection pan. Back out the screws and remove the pan and drip tube. Thoroughly clean the leakage collection pan and drip tube assembly using the same solutions and procedures for daily cleaning of components in the three partition sink.

### WARNING

**RESIDUE INDICATES REAR SEAL LEAKAGE. TAKE IMMEDIATE ACTION TO CORRECT THE SOURCE OF LEAKAGE.**

**QUARTERLY:** Thoroughly clean the condenser fins on all air-cooled machines. Remove all lint and dust with a vacuum or compressed air to clean fins. A dirty condenser greatly reduces refrigeration capacity and efficiency. When using compressed air, place a damp cloth on the opposite side of the condenser to catch the flying dirt or lint.

### WARNING

**THE CONDENSER FINS ARE VERY SHARP, USE EXTREME CAUTION WHEN CLEANING.**

**QUARTERLY OR AS NEEDED:** Replace all o-rings, rear seals, and scraper blades.

**SEMI-ANNUALLY :** It is advisable to clean and lubricate the idler arms to ensure their smooth operation. Use the following procedures.

1. Ensure that power to the dispenser is off.

### WARNING

#### HAZARDOUS MOVING PARTS

2. Remove the rear panel of the machine.
3. Disconnect the springs from the belt idler arm and torque idler arm (Exploded View) by placing needle nose pliers on one end of each spring and pull the end out of the retainer. **DO NOT** unscrew the belt idler screw.
4. Remove the nut from the pivot point of each idler arm assembly. Mark the individual idler arms for correct **reinstallation** after performing the maintenance.
5. Remove the idler arms and inspect the pivot point sleeves. These areas should be free of rust, debris, or dried lubricant. If any of these substances are found, they are to be removed.
6. Clean and polish each sleeve surface with a fine grade of emery cloth.
7. Sand the surface of each pivot stud, making sure it is highly polished. After this has been completed, apply **antisieze** to the stud and sleeve surface.
8. Reinstall the idler arms ensuring the torque idler arm is installed properly against the torque switch.
9. Install the belt ensuring that there is no grease on the belt or pulley. Step to the side of the unit and view the belt to ensure it is aligned (straight from top to bottom).
10. **Reattach** the torque idler arm spring and the belt idler arm spring to their respective positions.
11. Place the unit into operation. Check the product for proper consistency. Replace the rear panel.



**PERIODICALLY:** Sanitize the beverage system as follows:

- I. Beverage System Purge with Warm Water
- II. Beverage System Detergent Cleaning
- III. Beverage System Warm Water Rinse
- IV. Beverage System Sanitizing

The beverage system is a closed system from the remote premix source up to the product solenoid valve. Consult your local health authority for required sanitizing frequency.

### WARNING

**IF THE BEVERAGE SYSTEM IS OPENED TO THE ATMOSPHERE FOR ANY REASON BETWEEN THE REMOTE PREMIX SOURCE AND THE MACHINE, CLEAN AND SANITIZE THE BEVERAGE SYSTEM FROM ITS SOURCE.**

#### I. Beverage System Purge with Warm Water (Drain Machine of Product Before Proceeding)

1. Set all switches to the "OFF" position.
2. Pre-charge a transfer tank with at least two gallons of warm (100° to 120° F.) rinse water. The transfer tank equipped with a quick disconnect fitting or bag-in-the box adapter should be pressurized to a maximum of 60 psig and connected to the remote premix source. If your beverage system is equipped with a pump, the warm rinse water must be added to the intake side of the pump and the tank may require a vent instead of pressurization.
3. Remove the mix pan cover.
4. Set the dasher switch and the fill switch to the "ON" position. Open the spigot handle and remove water from the freezing cylinder to lower the level in the mix pan to activate the fill circuit. Continue to remove product as required to keep the fill circuit engaged.
5. Watch the mix pan and continue to purge the beverage system until the product flow into the pan is clear. When the product flow is clear, the rinse solution has filled the entire beverage system.
6. Set the dasher switch and the fill switch to the "OFF" position.

#### II. Beverage System Detergent Cleaning

1. Ensure all switches are set to the "OFF" position.
2. Precharge a transfer tank with at least two gallons of a warm detergent solution consisting of one (1) to two (2) ounces of an antibacterial hand dishwashing liquid detergent per gallon of luke warm water (100° to 120° F.). The transfer tank equipped with a quick disconnect fitting or bag-in-the-box adapter should be pressurized to a maximum of 60 psig and connected to the remote premix source. If your beverage system is equipped with a pump, the warm detergent solution must be added to the intake side of the pump and the tank may require a vent instead of pressurization.
3. Set the dasher switch and the fill switch to the "ON" position. Open the spigot handle and remove product from the freezing cylinder to lower the level in the mix pan to activate the fill circuit.
4. Continue to remove liquid from the spigot as required to keep the fill circuit engaged. Do not stop until all of the detergent solution has passed through the line.
5. Set the dasher switch and the fill switch to the "OFF" position.

#### III. Beverage System Warm Water Rinse

1. Ensure all switches are set to the "OFF" position.
2. Precharge a transfer tank with at least two gallons of warm (100° to 120° F.) rinse water. The transfer tank equipped with a quick disconnect fitting or bag-in-the-box adapter should be pressurized to a maximum of 60 psig and connected to the remote premix source. If your beverage system is equipped with a pump, the warm rinse water must be added to the intake side of the pump and the tank may require a vent instead of pressurization.
3. Set the dasher switch and the fill switch to the "ON" position. Open the spigot handle and remove the mild detergent solution from the freezing cylinder to lower the level in the mix pan to activate the fill circuit.
4. Continue to remove liquid from the spigot as required to keep the fill circuit engaged. Do not stop until all of the warm water rinse has passed through the line.
5. Set the dasher switch and the switch to the "OFF" position.

#### IV. Beverage System Sanitizing

1. Ensure all switches are set to the "OFF" position.
2. **Pre-charge** a transfer tank with at least two gallons of warm sanitizing solution. **CONSULT your** local health codes for the required residual chlorine content in your area. The sanitizing solution for this operation should be made from liquid **sanitizer** to assure that no **undissolved** crystals of powdered sanitizer could disrupt valve seats in the solenoid valve. The transfer tank equipped with a quick disconnect fitting or **bag-in-the-box** adapter should be pressurized to a maximum of 60 **psig** and connected to the remote **premix** source. If your beverage system is equipped with a pump, the sanitizing solution must be added to the intake side of the pump and the tank may require a vent instead of **pressurization**.
3. Set the dasher switch and the fill switch to the "ON" position. Open the spigot handle and remove the warm water rinse from the freezing cylinder to lower the level in the mix pan to activate the fill circuit.
4. Continue to remove liquid from the spigot as required to keep the fill circuit engaged. Do not stop until all of the warm sanitizing solution has passed through the **line**.
5. Set the dasher switch and the fill switch to the "OFF" position. **NOTE: CONSULT YOUR LOCAL HEALTH CODES TO DETERMINE THE MINIMUM REQUIRED LENGTH OF TIME FOR THE SANITIZING SOLUTION TO REMAIN IN CONTACT WITH THE PRESSURIZED LINE AND THE INTERNAL PARTS OF THE SOLENOID VALVE. THIS PROCEDURE IS ESTIMATED TO PROVIDE BETWEEN SEVEN AND TEN MINUTES OF SANITIZER CONTACT. IF LOCAL CODES REQUIRE A LONGER TIME, INCREASE THE GALLONS OF SANITIZING SOLUTION ACCORDINGLY, OR INTERRUPT THE PURGING PROCESS TO ATTAIN THE REQUIRED RESIDENCE CONTACT TIME WHEN YOU ARE CERTAIN THE SANITIZING SOLUTION HAS FILLED THE SYSTEM.**
6. Refill the remote premix source to supply the dispense head and reconnect the line.
7. Set the dasher switch and the fill switch to the "ON" position. Open the spigot handle and remove liquid from the freezing cylinder to lower the level in the mix pan to activate the fill circuit.
8. Continue to remove liquid as required to keep the fill circuit engaged.
9. Watch the solution enter the mix pan and continue to purge the beverage system until the product flow is the color of your premix supply. Components have been plumbed to assure complete discharge of the sanitizer during this purging operation. When the product flow is consistent in color, premix has filled the line and chased the sanitizing solution out.
10. **Set the** fill switch to the "OFF" position, **empty the** mix pan and freezing cylinder of all product, and perform the daily cleaning and sanitizing procedure.

**ANNUALLY:** Check the belts for signs of wear or cracking. Remove panels and clean the inside of the machine including the base, side panels, condenser, etc.

## Consistency Adjustment

The consistency control system (Fig. 18) is a very simple method of controlling the consistency of the finished product. The machine operates without a temperature control. Refrigeration is controlled by measuring the torque on the dasher motor and the consistency of the product. The tension of a spring against the torque idler determines how long the unit will run by activating a limit switch which turns the compressor on and off. The longer the compressor runs, the harder the product. The less it runs, the softer the product. This directly relates to product temperature.

Initial adjustments have been performed at the factory. However, to satisfy individual preferences, the following adjustments may be required.

1. Remove the right side panel (as you face the front of the machine).
2. Using a regular screwdriver, turn the consistency adjustment (torque adjustment) screw (Fig. 18) clockwise to make the product harder and counterclockwise to make the product softer. Do not adjust more than two turns each time. Do not attempt to adjust the belt idler screw on the other side of the machine marked "Do Not Adjust".

### WARNING

**EXTREME CAUTION SHOULD BE TAKEN TO KEEP HANDS AND TOOLS AWAY FROM MOVING PARTS. PERSONAL INJURY COULD RESULT.**

3. Wait until the compressor has cycled off and check the consistency.
4. Repeat steps 2 and 3 until the desired consistency is obtained.
5. Replace the right side panel and the machine is ready for continuous operation.

### NOTE

If product does not freeze to a hard enough consistency, the problem may not be that of the machine. To verify, use a standard thermometer to obtain the temperature of the product. If the temperature is between 21° and 24° F., the problem is not in the machine. Check to see that the product was prepared to the manufacturer's recommendation.

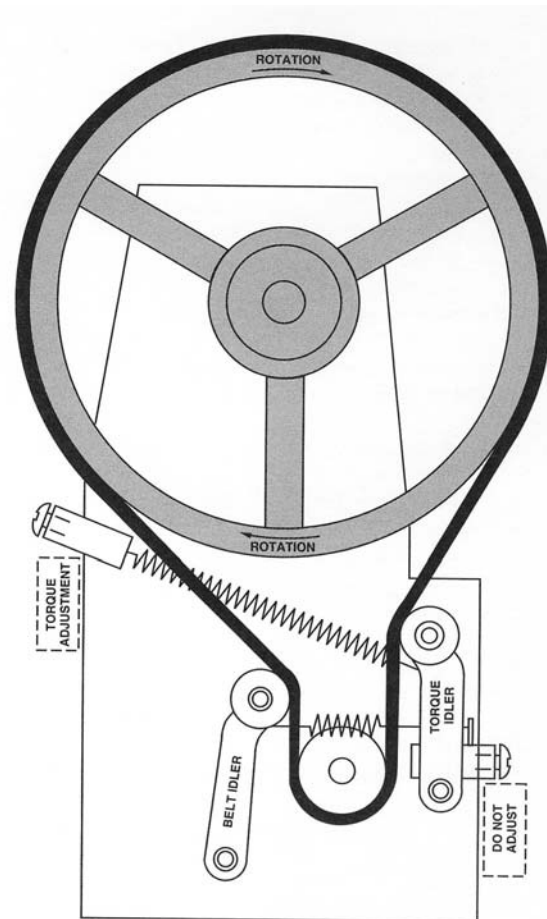

Fig. 18  
Consistency Adjustment

# Trouble Shooting

## 1. If product will not freeze to proper consistency:

- A. Check for properly mixed product. Replace mix as necessary.
- B. Check for dull scraper blades. Replace as necessary.
- C. Check condenser for dirt or obstructions. See Quarterly Maintenance (page 12).
- D. Ensure that compressor and fan will run.
- E. Check consistency adjustment and belt wear. Adjust and replace as necessary.

## 2. If squeaking or chirping noises are heard:

- A. Properly mix product. Replace as necessary.
- B. Check belt tension. Replace if worn.
- C. Check rear seal. Replace if necessary.
- D. Check lubrication.

## 3. If compressor does not run:

- A. Check mix out light.
- B. Inspect torque arms for free movement.
- C. Check the torque switch. It must click when depressed.  
See Consistency Adjustment (page 15).
- D. Inspect the condenser for dirt or obstruction. See Quarterly Maintenance (page 12).
- E. Check for proper clearance around machine. See Air Circulation (page 2).

## 4. If equipment leaks:

- A. Check o-rings and seals. Replace as necessary.
- B. Check for proper lubrication. Lubricate per instructions.
- C. Check premix line.

## 5. If unit freezes up:

- A. Using rerun mix. Change to new mix.
- B. Machine damage from previous freeze-up. Check freezing cylinder, dasher, and blades.
- C. Freezing cylinder surface too cold. Check consistency adjustment.
- D. Missing scraper blade or dasher assembly. Check these assemblies.
- E. Brix too low. Ensure premix is diluted to manufacturer's specification.

# Thermostatic Expansion Valve (TXV) Adjustment Procedure

**NOTE: THE FOLLOWING INFORMATION WAS OBTAINED FROM SPORLAN ENGINEERING BULLETIN 10-11. IT HAS BEEN REPRINTED HERE WITH THEIR PERMISSION. IF MORE INFORMATION IS REQUIRED PLEASE CONSULT THAT BULLETIN.**

The thermostatic expansion valve is erroneously considered by some to be a mysterious and complex device. As a result, many valves are needlessly adjusted or replaced when the cause of the system malfunction is not immediately recognized. Actually the TXV performs only one very simple function. IT KEEPS THE EVAPORATOR SUPPLIED WITH ENOUGH REFRIGERANT TO SATISFY ALL LOAD CONDITIONS. It is not a temperature control, torque control, suction pressure control, or a control to vary the compressor's running time. How effective the valve performs is easily determined by measuring the superheat as outlined in Diagram A.

Checking the superheat is the first step in a simple and systematic analysis of TXV performance. The following adjustment procedure is for the unlikely event that the TXV will require a field adjustment. Before attempting any adjustment, please verify that all other possibilities have been checked.

It has been found that in almost all circumstances, a TXV adjustment was not the problem. It was a symptom of another problem (examples: improper brix level of the product, worn or improperly installed scraper blades, improper torque settings, improper refrigerant added to the unit, a refrigerant leak, etc).

As you can see by this brief list, alot of other things should be checked before deciding a TXV adjustment or replacement is **required. The adjustment procedure is as follows. NOTE: The unit must be operating with a properly brixed product to check superheat. DO NOT ATTEMPT TO READ SUPERHEAT AND SUC-TION PRESSURES WITH NO LOAD ON THE REFRIG-ERATION SYSTEM.**

1. Remove the right side panel (as you face the front of the machine).
2. Before attempting any adjustment, determine what the superheat is. Install your refrigerant gauges on the suction access port on the dispensing head not at the condensing unit read and record the suction pressure while the unit is running right before the unit cycles the liquid line solenoid off. Next measure the suction line temperature as close to the TXV suction bulb as possible and record this information. Now convert the suction pressure to temperature using a temperature pressure chart (Diagram C), the refrigerant in this case is HP-62 (R-404A). Now subtract the pressure converted to temperature from the actual suction line temperature you measured. The difference is the superheat.

3. Compare that with what the superheat was when the unit was installed. This should have been noted on the operators manual and inside the unit at the time of install. The superheat and the suction pressure recorded at initial start up are best for comparison. If in the event that this was not done, the suction pressure right at the compressor cycling off will be between 27-35 psig. The superheat will be around 15°-20° F. depending upon the ambient and load conditions (Settings apply to single head installs only).
4. Remove the superheat adjustment stem cap (Diagram B). To reduce the superheat, turn the adjusting stem counterclockwise. To increase the superheat turn the adjusting stem clockwise. When adjusting the valve , make no more than one full turn at a time and observe the change in superheat closely to prevent overshooting the desired setting. Allow plenty of time between adjustments for the new balance point to be established. As much as 30 minutes or 6 complete compressor cycles may be required to seek its new balance point.
5. Record the system suction pressure and superheat right at the point that the unit cycles off the liquid line solenoid valve. Be sure to place this information in the space below. This will serve as a record for any future references.
6. Replace the superheat adjustment stem cap. Be sure to snug the cap down. Remove your gauges and install the suction access port cap. Now install the side panel.

## System Pressure & Superheat Record

Date	Superheat	Suction Pressure	Technician

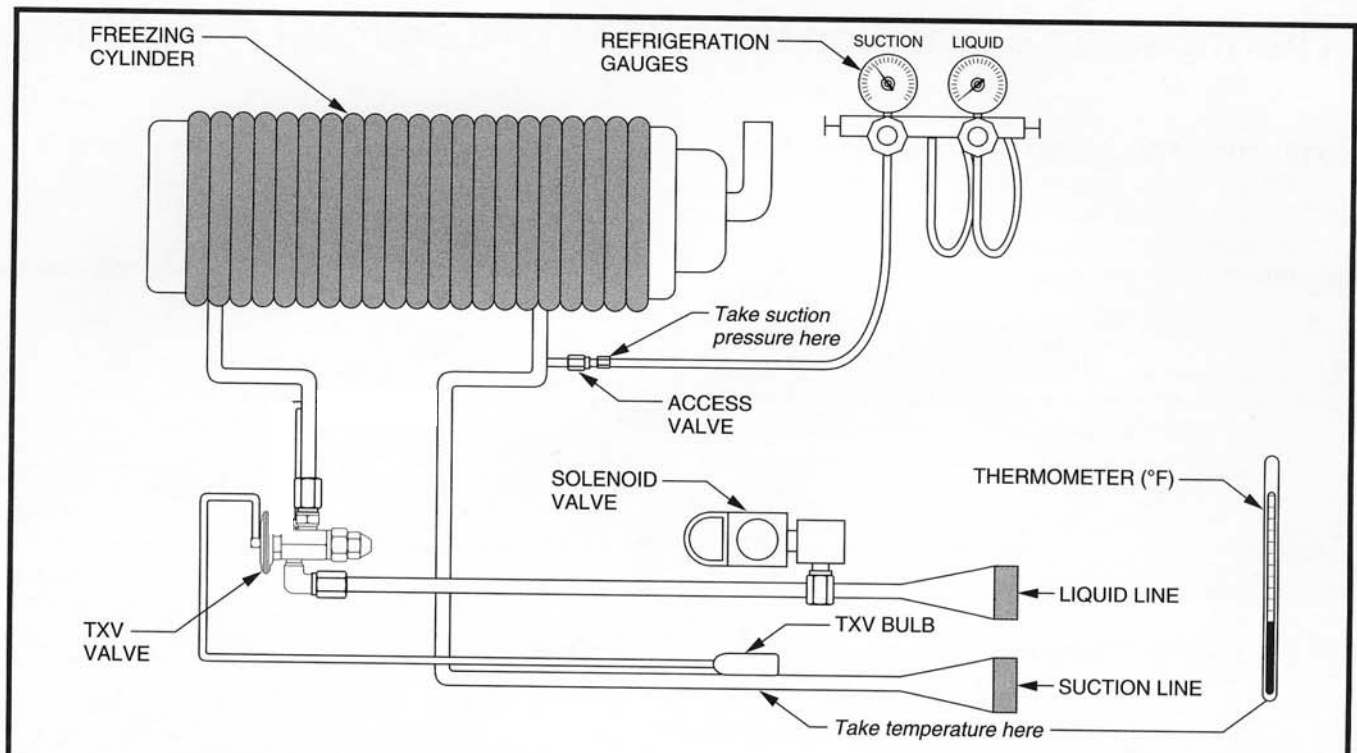

**TO CALCULATE SUPER HEAT:**

- Temperature at suction line (near TXV bulb)
- Suction pressure converted to temperature (from dispense head access valve)
- = Superheat

**EXAMPLE:  
HP-62 (R-404A)**

- 14.8° F. (Suction line temperature near TXV bulb)
- 30.0 PSIG suction pressure at head access valve
- 30.0 PSIG = (-2.2° F.) saturated vapor dew point
- 14.8° F.
- (-2.2)° F.
- = 17.0° F. Superheat

**Diagram A**

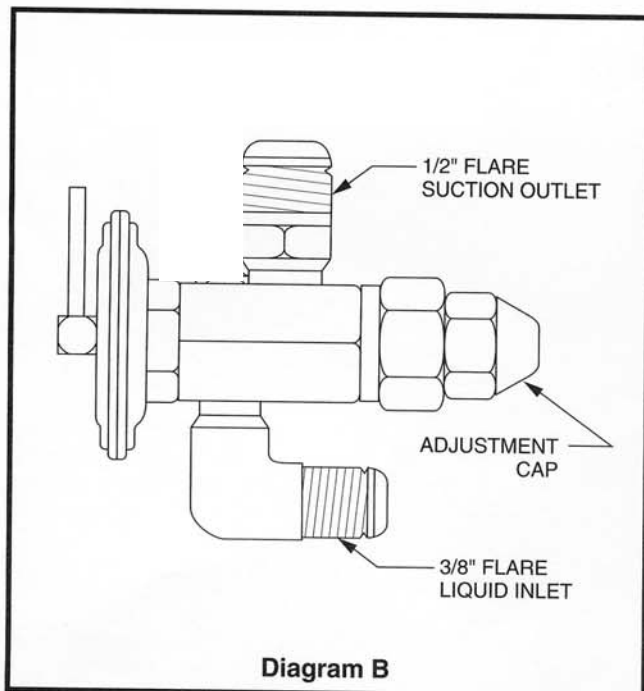

**Diagram B**

**Refrigerant Reference Chart**

PSIG	HP62 (R404A)
20	-15° F.
22	-12° F.
24	-10° F.
26	-7° F.
28	-5° F.
30	-3° F.
32	-1° F.
34	1° F.
36	3° F.
38	5° F.
40	7° F.

**Diagram C**





451 E. County Line Road  
P.O. Box 1089  
 Mooresville, Indiana 46158-5089

[www.saniserv.com](http://www.saniserv.com)

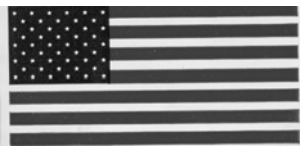

*Proudly made in the U.S.A.*

Technical Publication  
Publ. No. 82174  
Updated 5/16