

# MODULUS

## Advanced Communications Module-8AI

Modulus Advanced Communications modules extend the communications, I/O capacity and processing power of Modulus SCADA controllers. They include support for Modbus, DNP3, Bacnet, DF1, and Ethernet IP as well as modern secure encrypted protocols. These modules have significantly greater performance and memory resources than Modulus Standard Communications and I/O modules for advanced, processing intensive applications. ICLs ScadaBuilder software is used for programming and configuration, and legacy ScadaBuilder (v5) programs from older devices can be run on the new hardware.

Advanced Communications modules have four high-speed digital inputs, eight Process Analog Inputs (current and voltage) and the option of four additional universal analog inputs or analog outputs.

Advanced Communications modules have four serial ports, two with configurable interfaces that support RS-232, RS-485 (2-wire), and RS-422 (4-wire) operation, and a third port that supports RS-232 and RS-485 (2-wire) operation. The high-speed bus port supports general purpose RS-485 communications if the module is not interconnected with other Modulus I/O modules. A USB port supports for both plug-in memory and communications devices.

### STANDALONE OPERATION

Modulus Advanced Communications modules can serve as standalone devices with SCADA communications, local and web human machine interfaces (HMIs), trending and data logging, alarming, reporting, and programmable control.

### COMMUNICATIONS

Advanced Communications modules have an Ethernet port, a USB port, and four serial ports to communicate with Modbus, DNP3 and Bacnet devices, as well as Allen Bradley PLCs. The module can also serve as a communications concentrator or master controller.

### GRAPHICAL, MOBILE, AND LOCAL HMIs

Configurable graphical web and mobile device interfaces are built into these modules. The front panel display can also be customized to show live process values and states, and make setting changes.

### HISTORICAL TRENDING AND EVENT LOGGING

Advanced Communications modules have an internal solid state flash disk, as well as a micro SD memory card slot to record over 100 years of data! You can retrieve and display historical data with built-in web tools and extract trend and event data as spreadsheet files.

### REPORTING

Reports can be created in minutes showing live values, production totals, trend and event data, alarm summaries, etc. Customize reports with your own logos and graphics. Call up reports on demand, or have them automatically transferred to your computer.



8x-7002 8DI, 4DO, 8AI  
8x-7003 8DI, 4DO, 8AI, 4AI  
8x-7012 8DI, 4DO, 8AI, 4AO

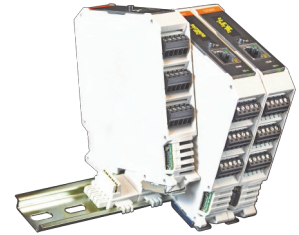

### Modulus Advanced Communications Module

- 1 FAST 32-BIT PROCESSOR WITH HARDWARE FLOATING POINT
- 1 ETHERNET PORT
- 1 USB (HOST) PORT
- 4 SERIAL PORTS (BUS PORT PLUS 3 GENERAL PURPOSE PORTS)
- 4 DISCRETE/HIGH-SPEED PULSE INPUTS
- 8 PROCESS ANALOG INPUTS (VOLTAGE and CURRENT)
- 4 OPTIONAL ADDITIONAL ANALOG INPUTS OR OUTPUTS

### ALARMING

An Advanced Communications module can manage alarm conditions on any of its local inputs, as well as thousands of conditions monitored from other modules and devices. Alarms can be displayed locally, and annunciated by e-mail or text message when an Internet connection is available. The module maintains a journal spreadsheet file of when alarms occurred, when they were acknowledged, by whom, and when the alarm conditions cleared.

### PROGRAMMABLE LOGIC

Advanced Communications modules support programmable logic written in any mix of the five standard IEC-61131 languages including Ladder Logic, Function Block, Structured Text, Sequential Function Chart as well as Flow Charting.

### PUMP & PID CONTROL

Advanced Communications modules have built-in pump control (float or level) and PID control blocks.

### GAS FLOW CALCULATIONS

Advanced Communications modules support the calculations, journaling and traceability required for temperature compensated gas flow monitoring.

### REDUNDANCY

Advanced Communications modules support redundancy for enhanced reliability. If a module goes off-line, a designated backup can take over automatically.

# Modulus ADVANCED COMMUNICATIONS (8 Process Analog Inputs) Module Specifications

<b>FIELD I/O</b>	
<b>Digital Inputs:</b>	4 Non-isolated DC or contact closure, DC to 20KHz maximum
Input Range:	Contact closure or open collector driver to ground, or 0 to 30Vdc (ON=<1.5V, OFF > 2.5V), <b>60Vdc absolute maximum</b>
Input Current:	0.5mA (internal current source)
Filtering:	Individually configurable: 5Hz, 10Hz, 20Hz, 50Hz, 100Hz, 500Hz, 1KHz, 2KHz, 5KHz, 10KHz+
<b>Process Analog Inputs:</b>	8 16-bit, Delta Sigma, individually selectable input ranges
Input Ranges:	<ul style="list-style-type: none"><li>• 20mA (minimum input for full accuracy is 0.5mA)</li><li>• 5V and +/- 5V, 10V and +/- 10V, 30V</li></ul>
Maximum signal level:	35Vdc on any range
<b>OPTIONAL FIELD I/O</b>	
<b>Analog Inputs (option)</b>	4 16-bit, Delta Sigma, individually selectable input ranges
Input Ranges:	<ul style="list-style-type: none"><li>• 20mA (minimum input for full accuracy is 0.5mA)</li><li>• 5V and +/- 5V, 10V and +/- 10V, 30V</li><li>• +/- 75mV</li><li>• 65K ohms</li><li>• J, K, T, E, R,S thermocouple (ungrounded type)</li><li>• 2.2K, 10K (type II, II and 11.K shunt)</li></ul>
<b>Analog Outputs (option)</b>	4 12-bit
Output Ranges:	<ul style="list-style-type: none"><li>• 20mA</li></ul>
<b>COMMUNICATIONS</b>	
<b>Ethernet:</b>	1 10/100mb/s (10/100 Base-T)
SCADA Protocols	Modbus TCP & UDP (master/slave), Ethernet IP (master/slave), DNP3, BACNET, SDX (128-bit encryption, master/slave), Ethernet-Serial bridging
Internet Protocols	HTTP (server), FTP (server & client), ICMP (ping; server and client), NTP (client), DHCP (server & client), DNS, DDNS, Telnet
<b>USB:</b>	1 Host port, mini type B
<b>Serial:</b>	1 RS-485 (This port is available if not used for bus communications with other modules.)
	2 RS-232, RS-485, RS-422 (These ports are always available for general purpose communications.)
	1 RS-232, RS-485 (This port is always available for general purpose communications.)
Baud Rates	115K, 38.4K, 19.2K, 9600, 4800, 2400, 1200 baud
Protocols	Modbus RTU (master/slave), DF1 (slave), BACNET, DNP3, SDX (128-bit encryption, master/slave), NMEA 0183 (GPS)
<b>HMIs</b>	
<b>Local:</b>	128x32 graphical, wide temperature range yellow OLED and single pushbutton
<b>Graphical:</b>	Web based, graphic library included. Compatible with most browsers, including Internet Explorer, Firefox, Chrome, Safari, Android
<b>Mobile:</b>	Web based, text only. Compatible with most browsers, including Internet Explorer, Firefox, Chrome, Safari, Android
<b>PROGRAMMING</b>	
<b>Languages:</b>	IEC-61131 standard: Ladder Logic, Function Block, Structured Text, Sequential Function Block, Instruction List, Flow Chart
<b>Capacity:</b>	32 MB
<b>STORAGE</b>	
<b>Registers:</b>	65535 registers: Numeric, Boolean, Strings (10K maximum)
<b>Internal Flash disk:</b>	32MB
<b>Removable disk:</b>	Micro SD Card (up to 256GB, supplied by customer)
<b>CLOCK</b>	
<b>Real Time Clock:</b>	Temperature compensated with lithium battery backup power
Stability:	+/- 3ppm from -30°C to 70°C
<b>GENERAL</b>	
<b>Input Power:</b>	10Vdc to 30Vdc
<b>Power Consumption</b>	145 mA @ 12Vdc / 72 mA @ 24Vdc
<b>Field Wiring Termination:</b>	[81-70xx] screw terminal blocks [82-70xx] lever terminal blocks, 3.5mm, 22 to 14GA wires
<b>Temperature:</b>	-40°C to 70°C (operating), -40°C to 85°C (storage)
<b>Humidity:</b>	<95% RH (non-condensing)
<b>Enclosure:</b>	Polyamide, light gray (RAL 7035)
<b>Mounting:</b>	35mm DIN rail with bus connector block

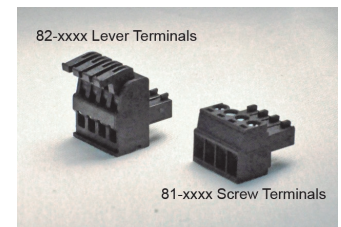

Specifications subject to change without notice. Consult factory to ensure that you are working with current information.

# Modulus ADVANCED COMM (8 Universal Analog Inputs) Module DIMENSIONS and WIRING

## DIMENSIONS and WIRING

 Refer to the installation manual for additional installation details and precautions.

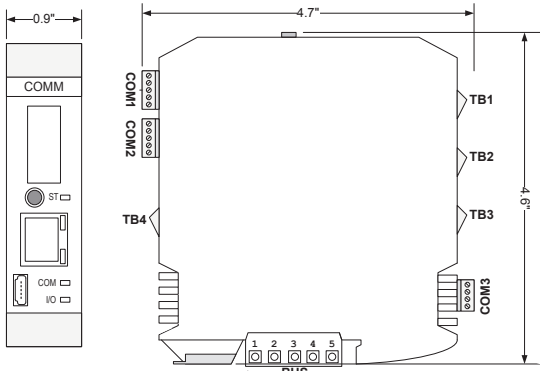

Terminal	Function
1	-485
2	+485
3	RESET#
4	GND
5	+V

Terminal Block	Inputs/Outputs
TB1	DI1 - DI4
TB2	AI1 - AI4
TB3	AI5 - AI8
TB4	optional UI/AO

## DISCRETE INPUTS (TB1)

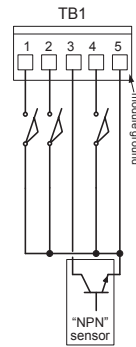

All discrete inputs are referenced to the ground terminal (5). This terminal is connected internally to the module's power supply ground.

The Discrete Inputs accept contact closures or open-collector ("NPN" style) input signals. An external pull-up resistor is not required.

## PROCESS ANALOG INPUTS (TB2 and TB3)

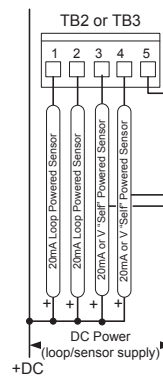

The process analog inputs on terminal blocks 2 and 3 share a common that is isolated from all other I/O points.

## General Purpose Communications Ports COM1 & COM2 (modes are software configured)

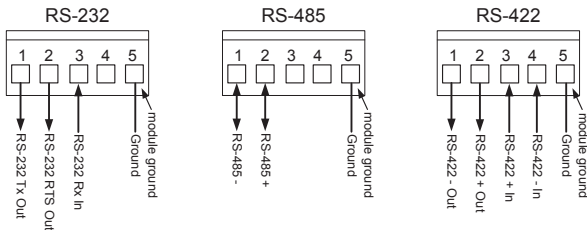

### Typical RS-232 Wiring to Modem/Radio

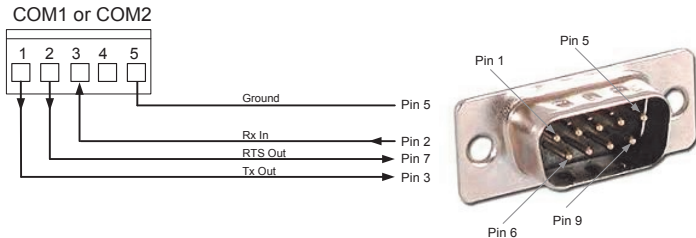

## General Purpose Communications Port COM3 (modes are software configured)

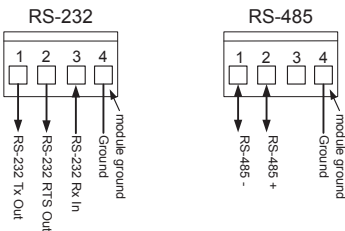

### Typical RS-232 Wiring to Modem/Radio

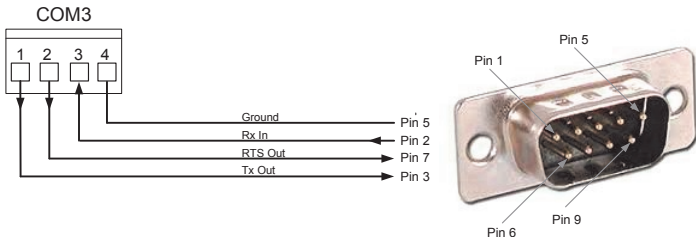

## OPTIONAL ADDITIONAL UNIVERSAL ANALOG

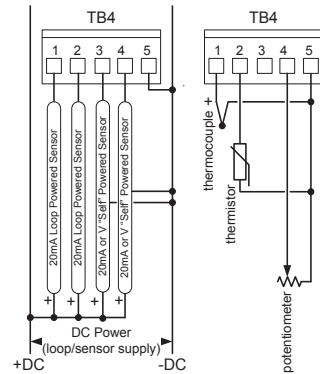

The optional universal analog inputs on terminal block 4 share a common that is isolated from all other I/O points. These inputs support 20mA and voltage signals, as well as 2-wire sensors (RTDs are not supported).

## OPTIONAL ANALOG OUTPUTS (TB4)

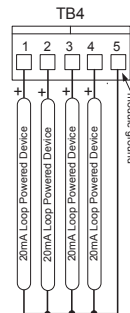

The optional analog outputs on terminal block 4 share a common with the module's main input power. The power is also utilized as the source for analog output loop power. Typically this is 24Vdc.



Industrial Control Links, Inc.  
1364 Blue Oaks Blvd. Roseville, CA 95678  
**530.888.1800**