

IMPACT 200 LIFTERS & TOOLS

- DRAWINGS & MEASUREMENTS

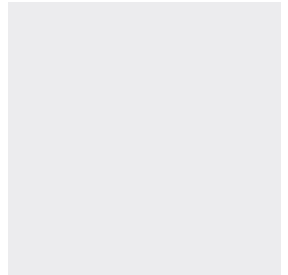
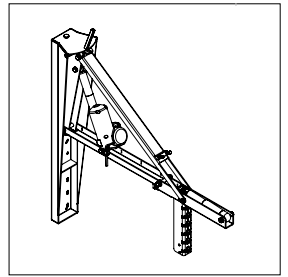
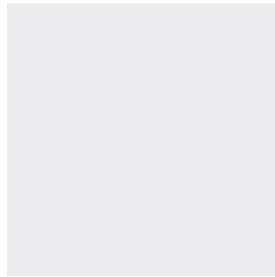
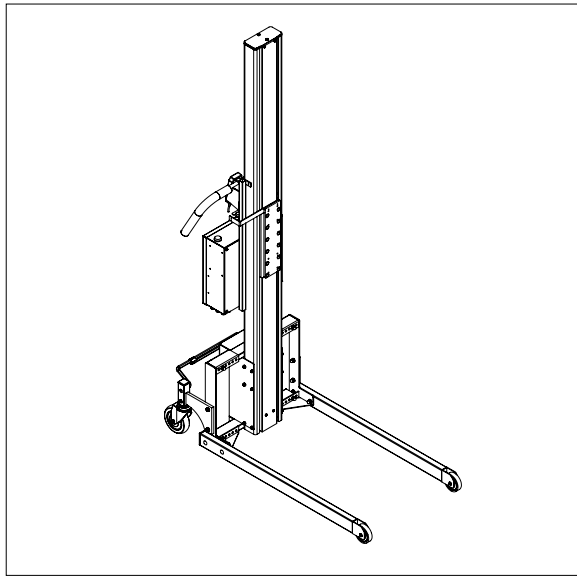
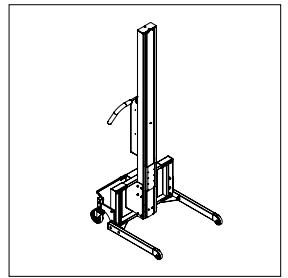
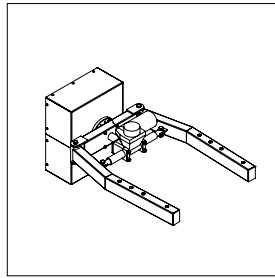
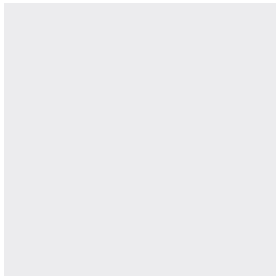
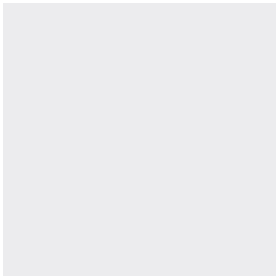

IMPACT 200

3 MAST HEIGHTS AND 13 LEG/WHEEL OPTIONS

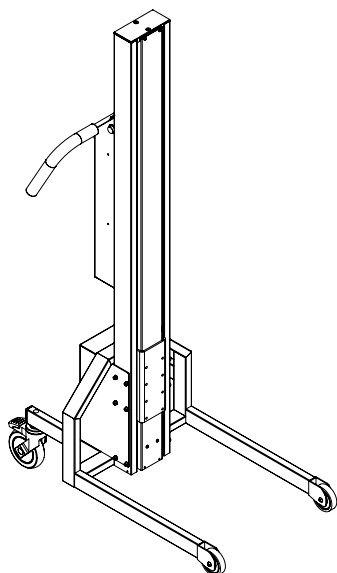

200 L/M/H standard legs

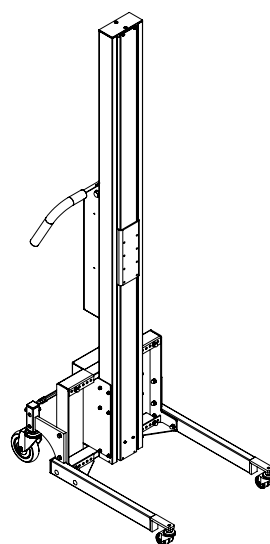

200 L/M/H FC - Flexleg type 1

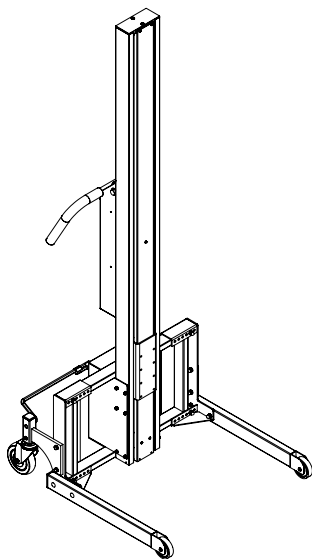

200 L/M/H FC - Flexleg type 2

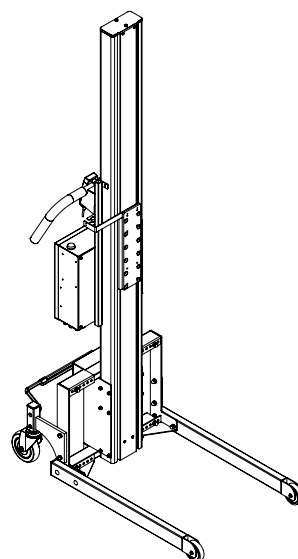

200 L/M/H FC3 - For electric tools

IMPACT 200

LIFTERS - DRAWINGS & MEASUREMENTS

- All measurements in mm

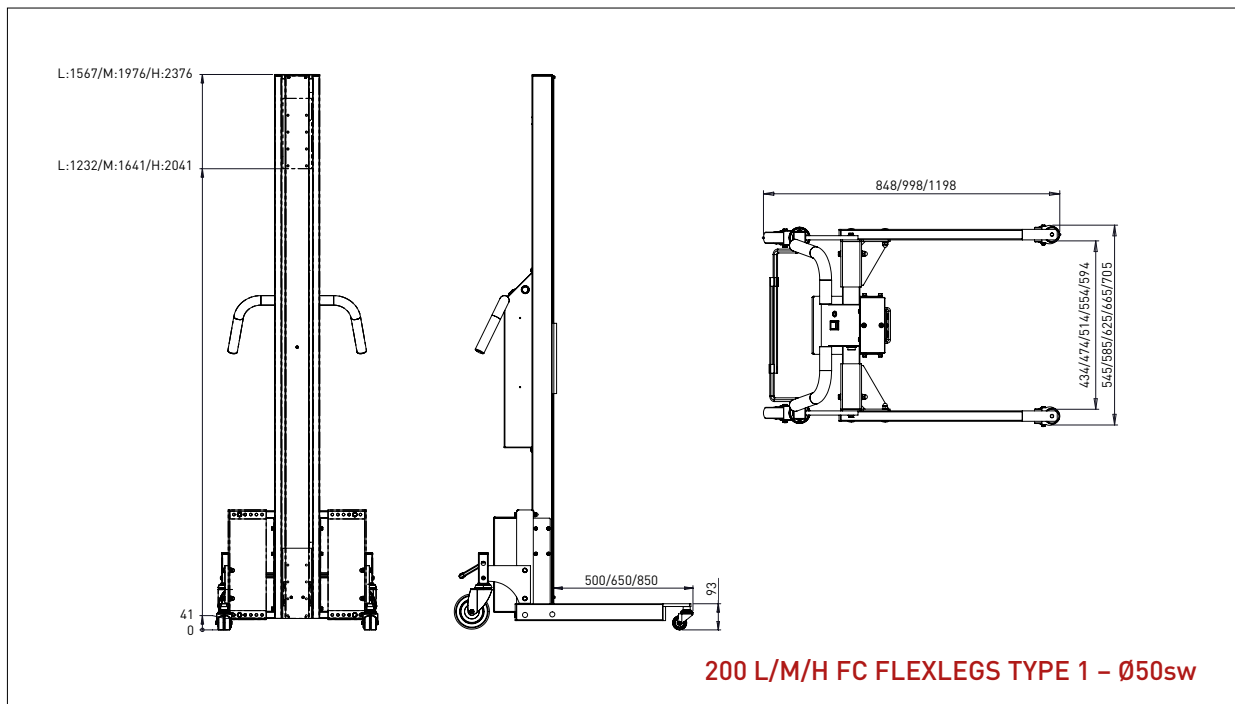
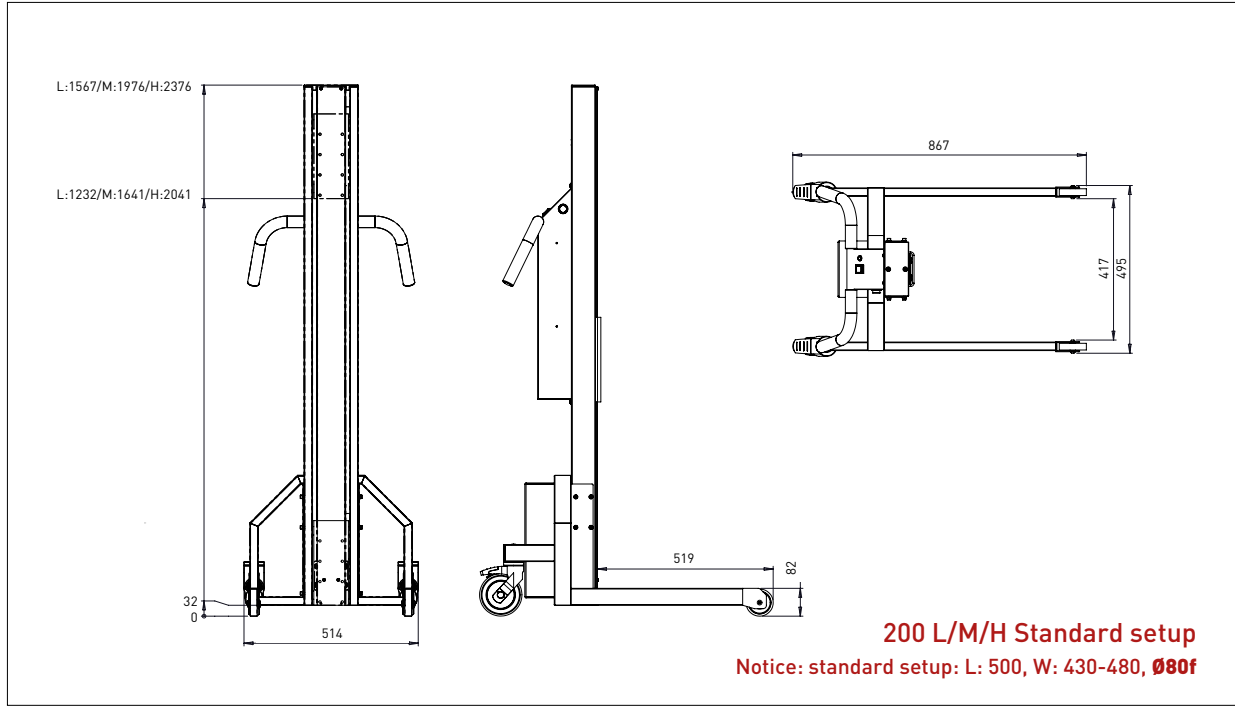

IMPACT 200

LIFTERS - DRAWINGS & MEASUREMENTS

- All measurements in mm

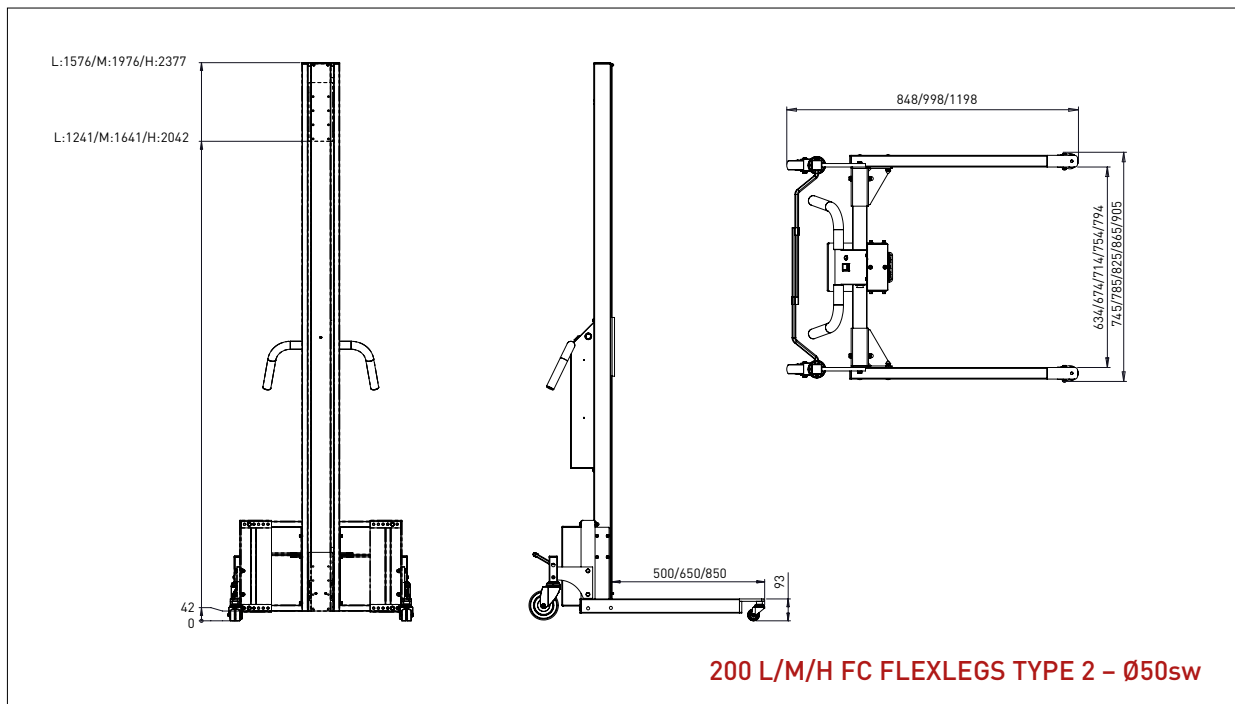
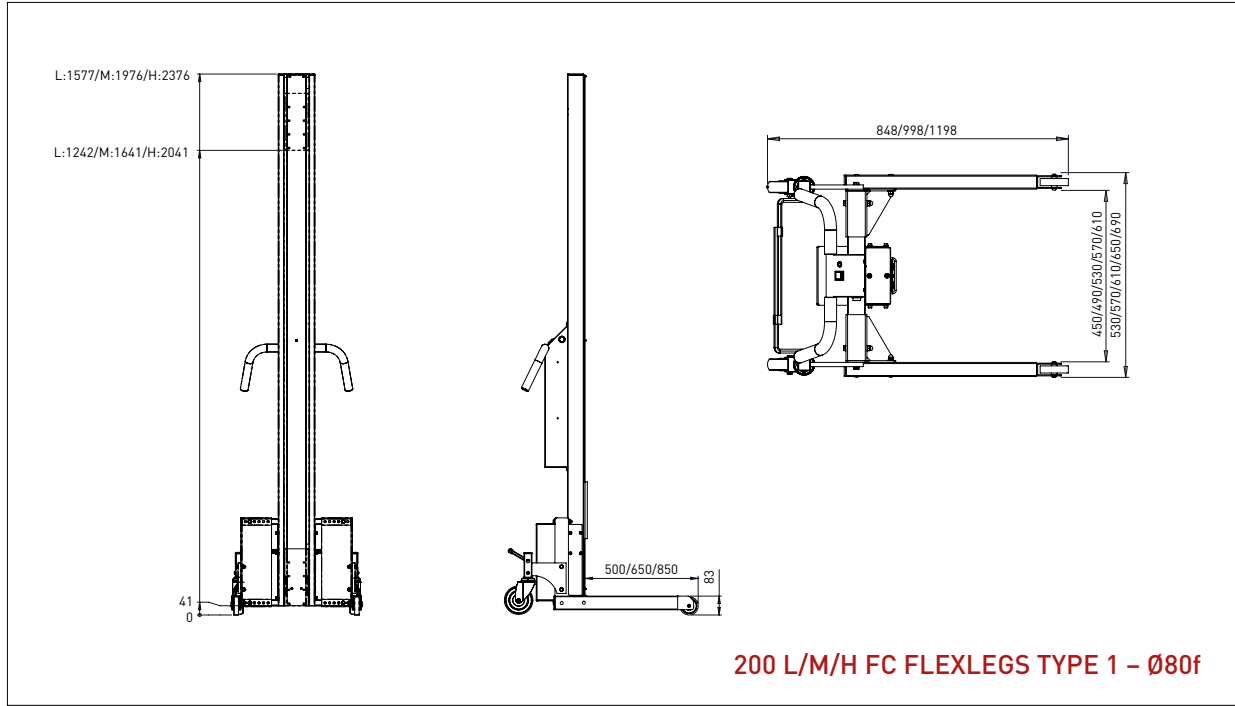

IMPACT 200

LIFTERS - DRAWINGS & MEASUREMENTS

- All measurements in mm

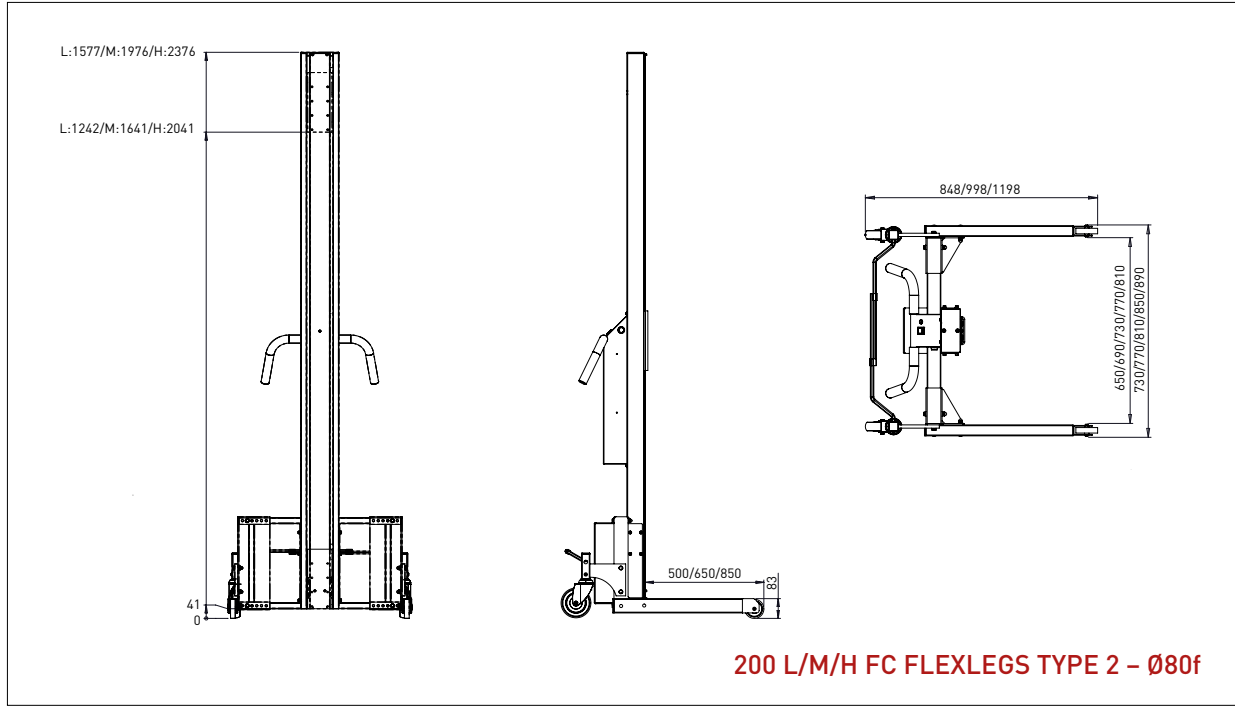

IMPACT 200 FOR ELECTRIC TOOLS

LIFTERS - DRAWINGS & MEASUREMENTS

- All measurements in mm

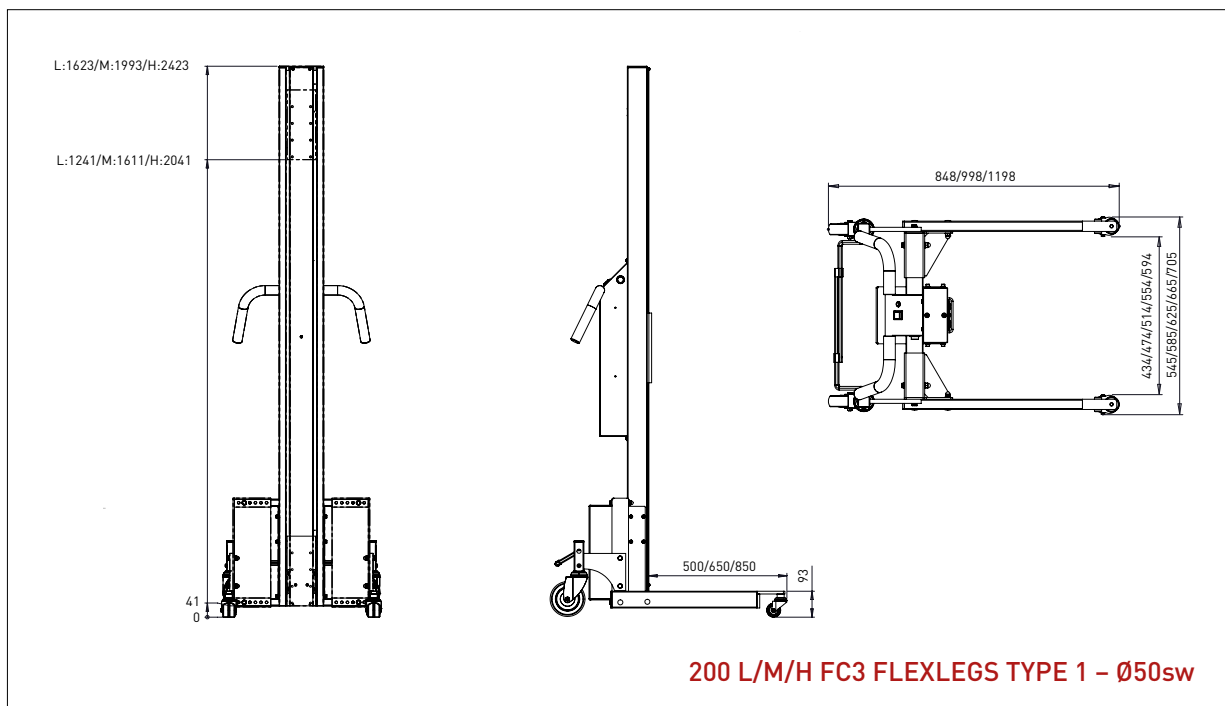
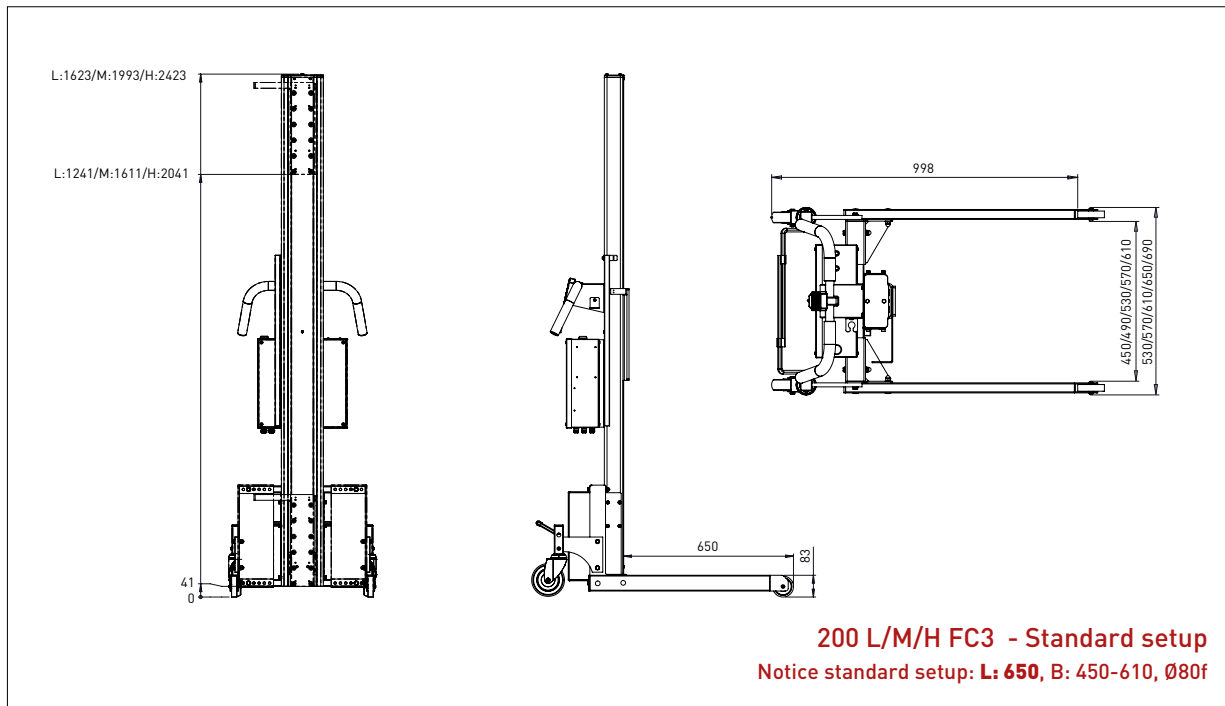

IMPACT 200 FOR ELECTRIC TOOLS

LIFTERS - DRAWINGS & MEASUREMENTS

- All measurements in mm

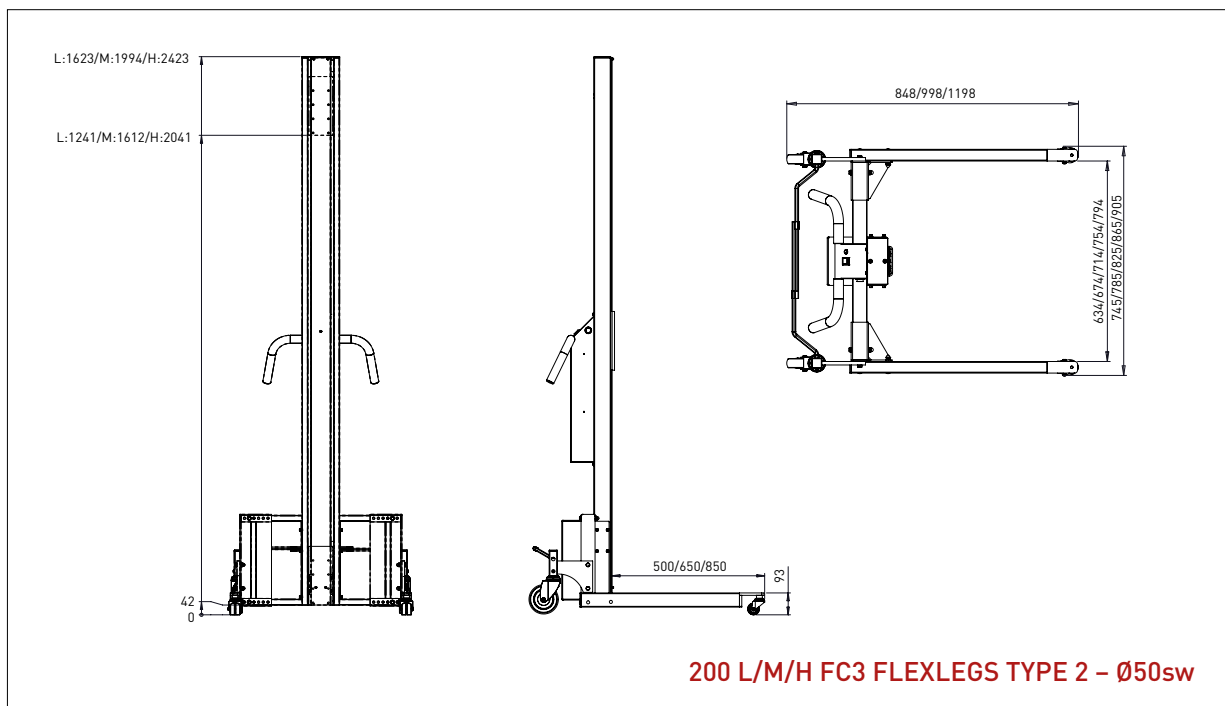
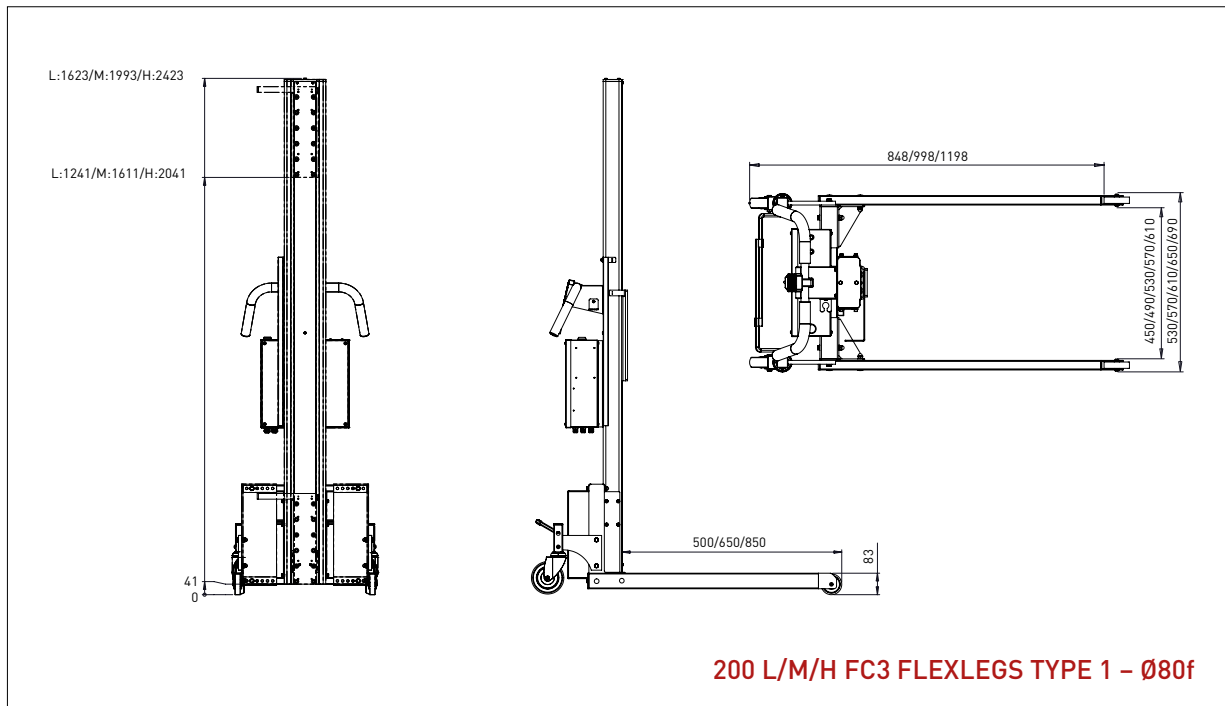

IMPACT 200 FOR ELECTRIC TOOLS

LIFTERS - DRAWINGS & MEASUREMENTS

- All measurements in mm

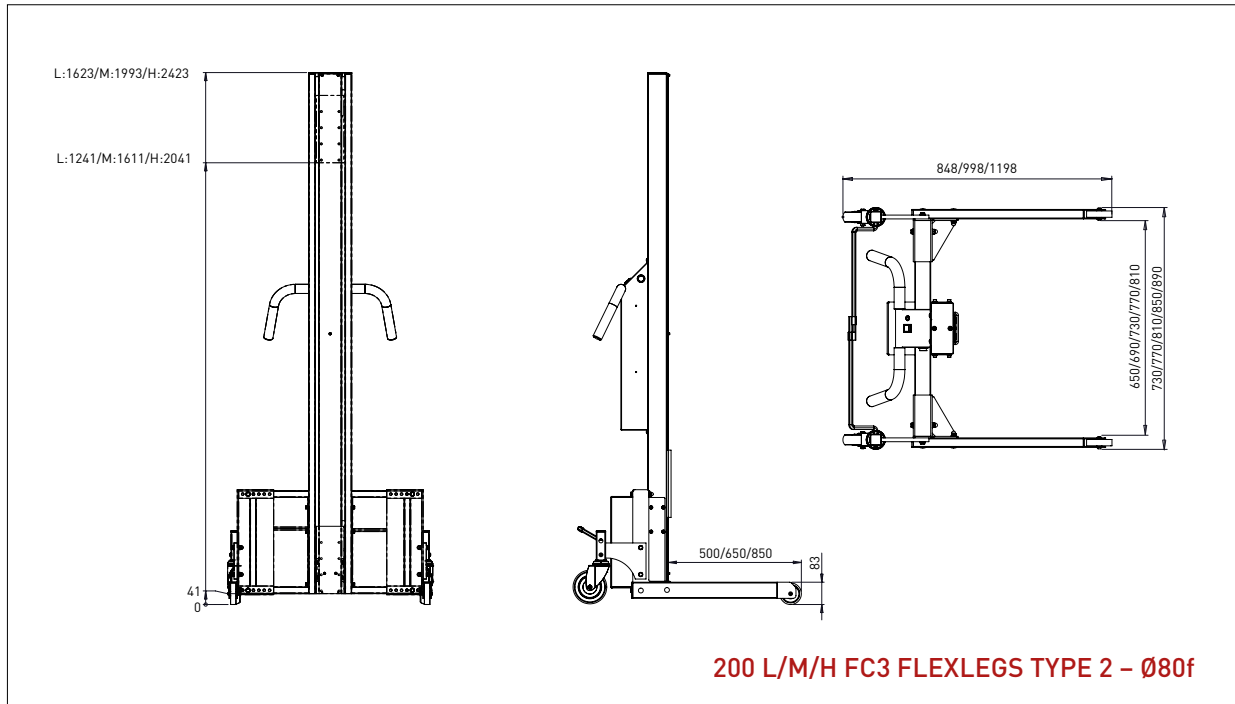

IMPACT 200 / TOOLS

PLATFORMS STAINLESS

- All measurements in mm

PLATFORM STAINLESS – EP3

L x W: 500 x 400 mm

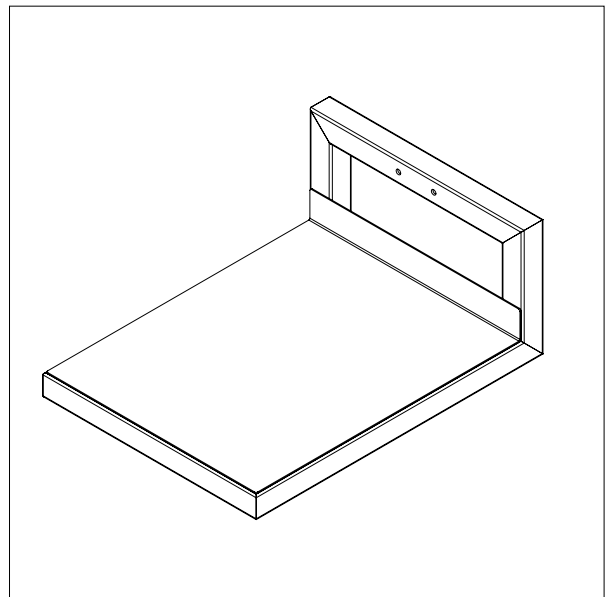
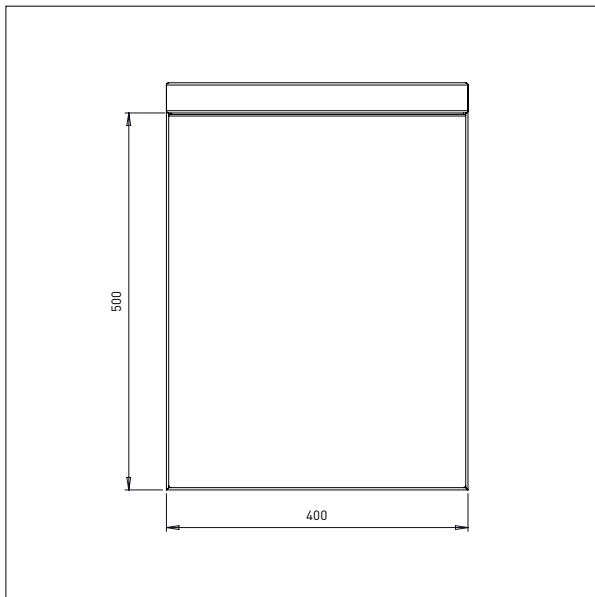

PLATFORM STAINLESS – EP4

L x W: 500 x 500 mm

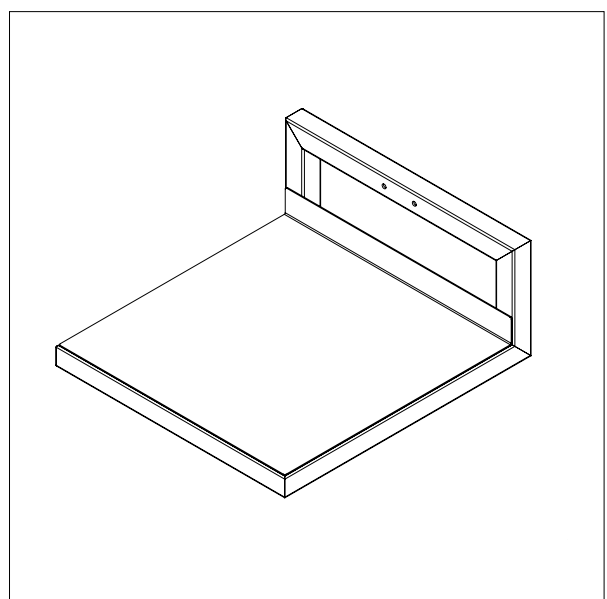
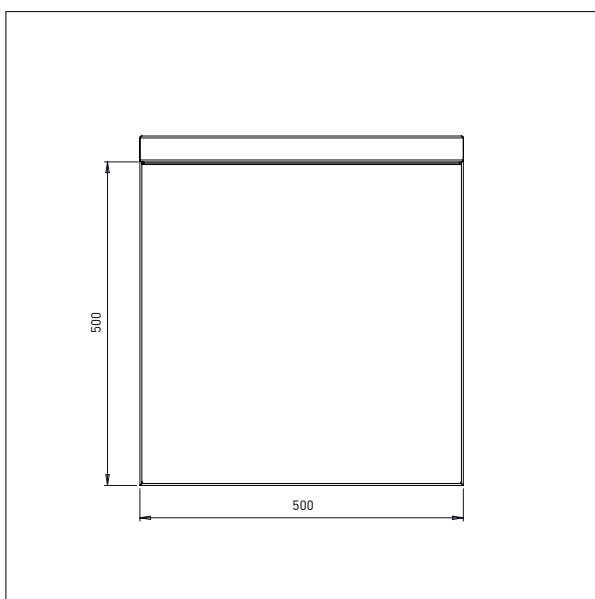

IMPACT 200 / TOOLS

BOOMS

- All measurements in mm

BOOM - D3

Ø x L: 60 x 500 mm

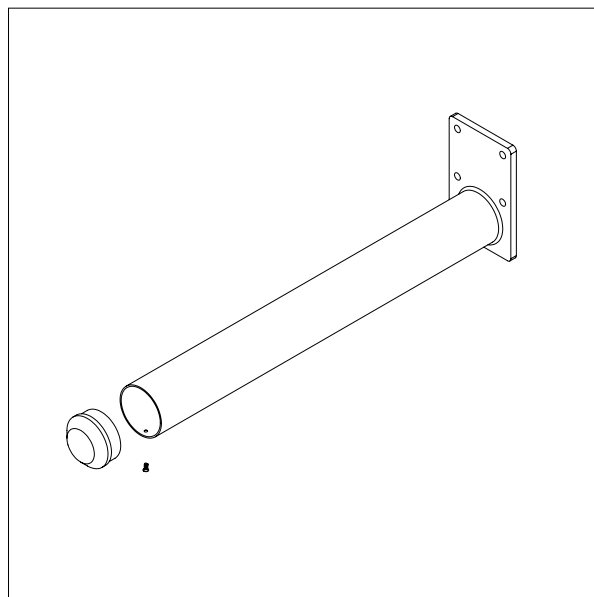
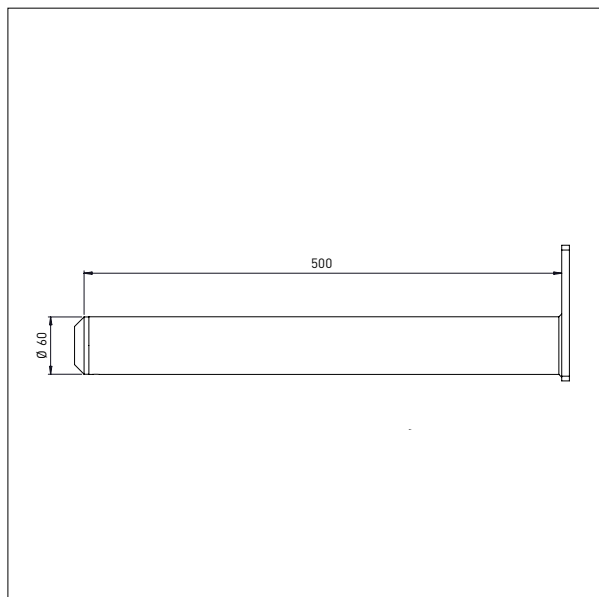

BOOM - D4

Ø x L: 60 x 800 mm

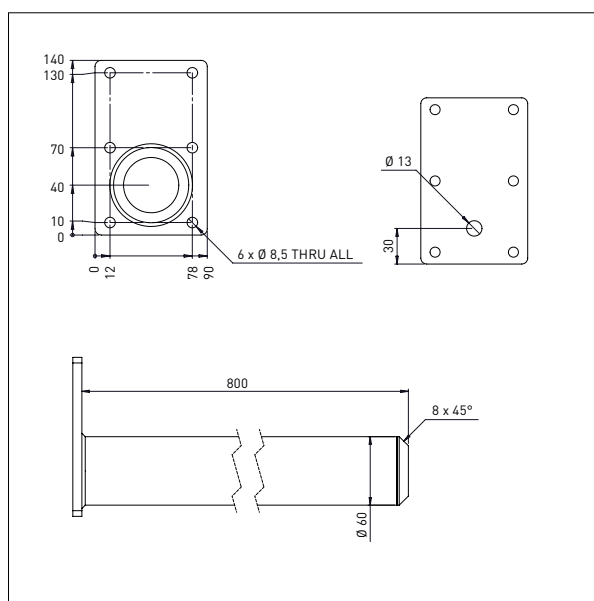
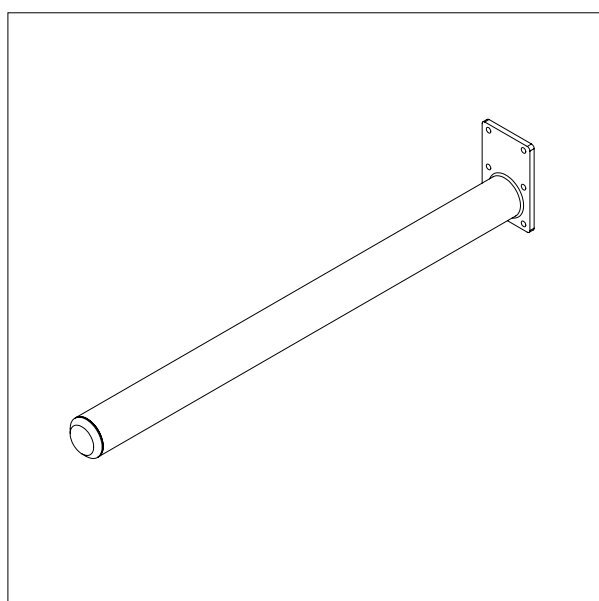

IMPACT 200 / TOOLS

DOUBLE BOOMS

- All measurements in mm

DOUBLE BOOM – DD3

Ø x L x W: 40 x 500 x 300 mm

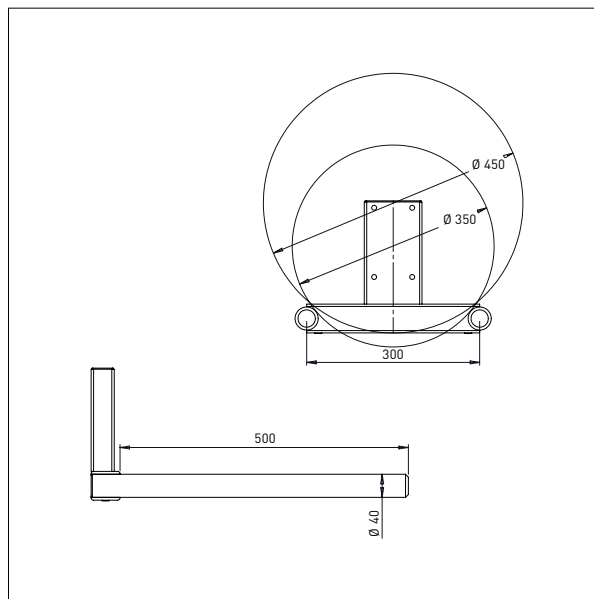
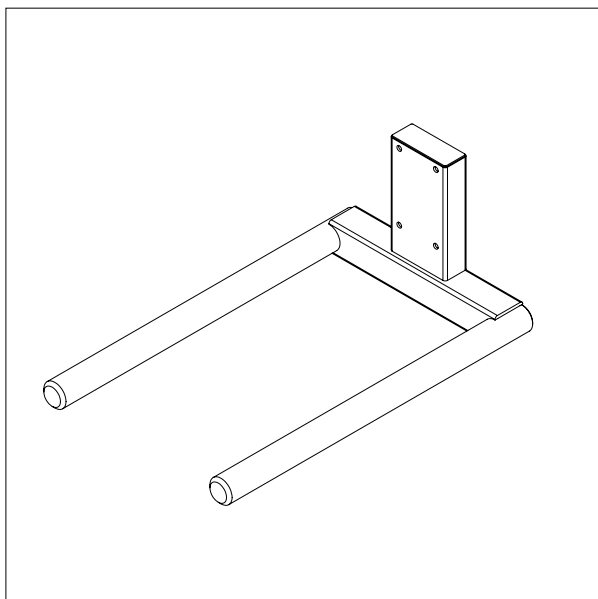

DOUBLE BOOM – DD4

Ø x L x W: 40 x 500 x 400 mm

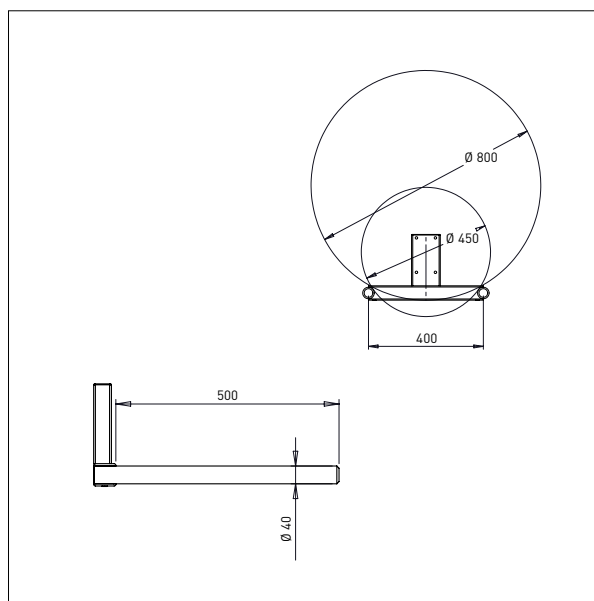
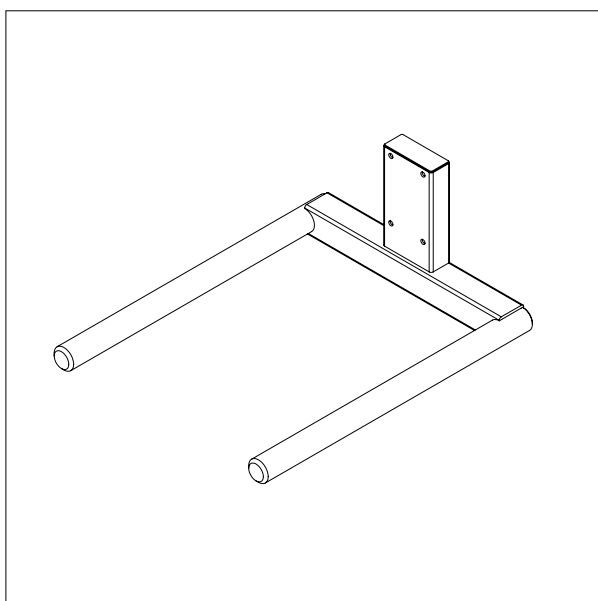

IMPACT 200 / TOOLS

FORK

- All measurements in mm

FORK - G3

L x W: 570 x 400 mm

For 600 x 400 mm boxes

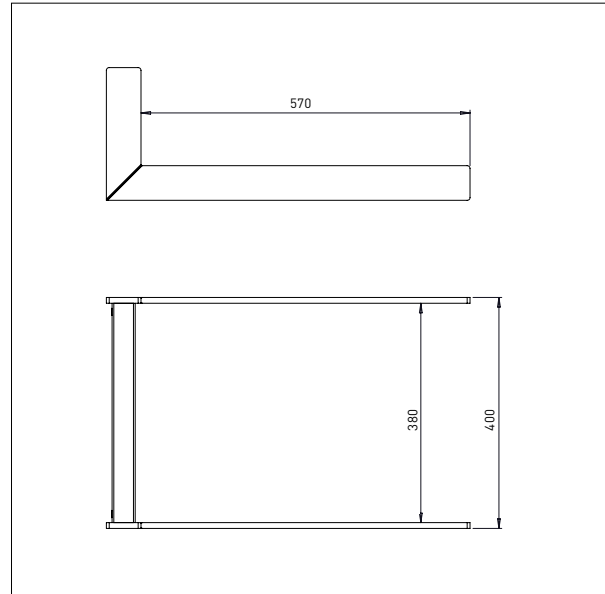
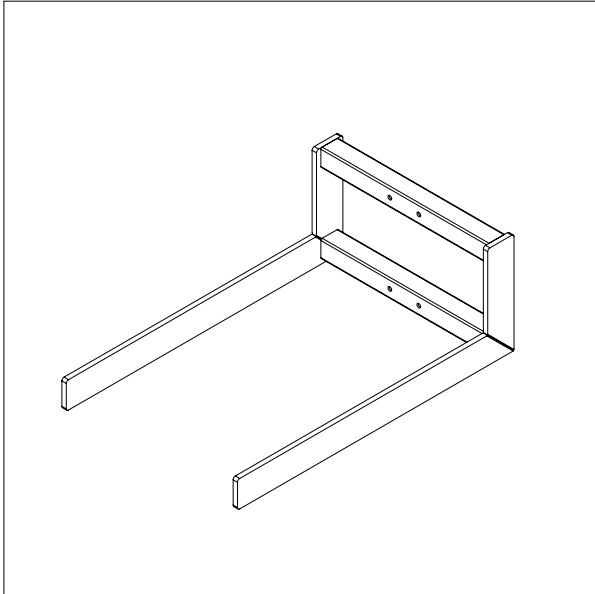

IMPACT 200 / TOOLS

CRANE ARMS

- All measurements in mm

CRANE ARM - KA3

L: 600

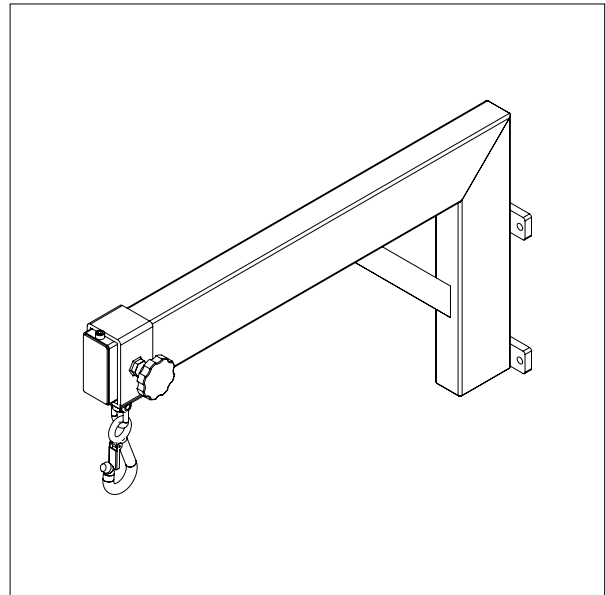
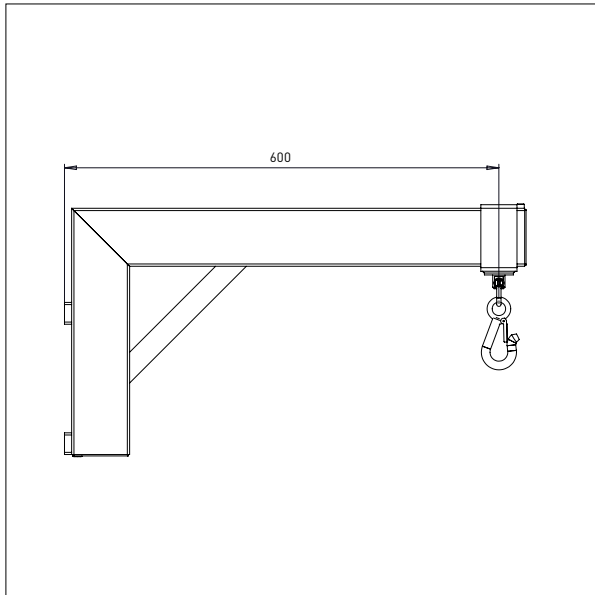

CRANE ARM - KA4

L: 800

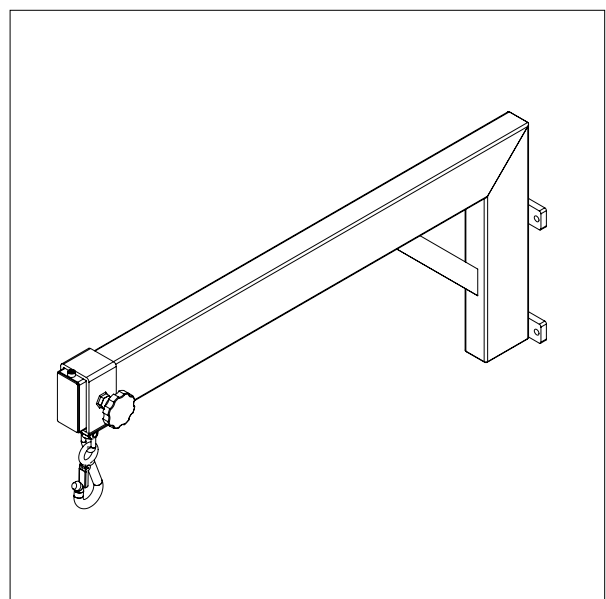
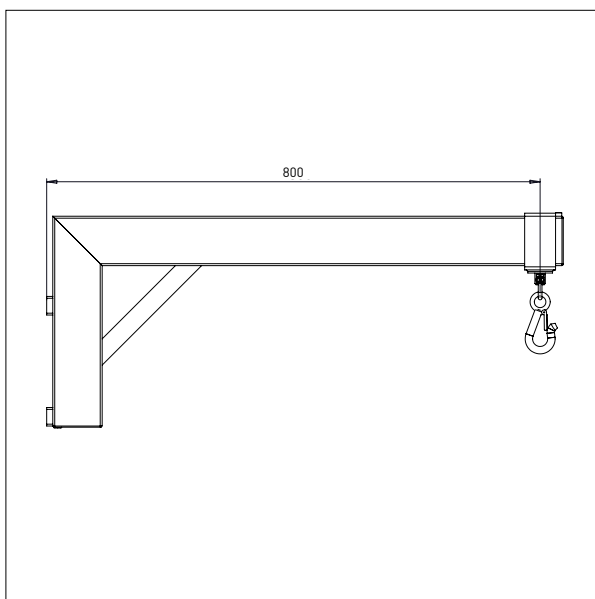

IMPACT 200 / TOOLS

REEL MANIPULATOR

- All measurements in mm

REEL MANIPULATOR - MRP2

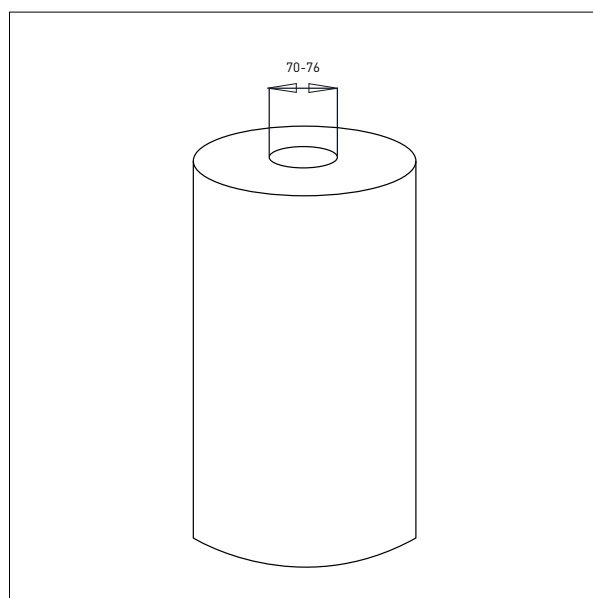
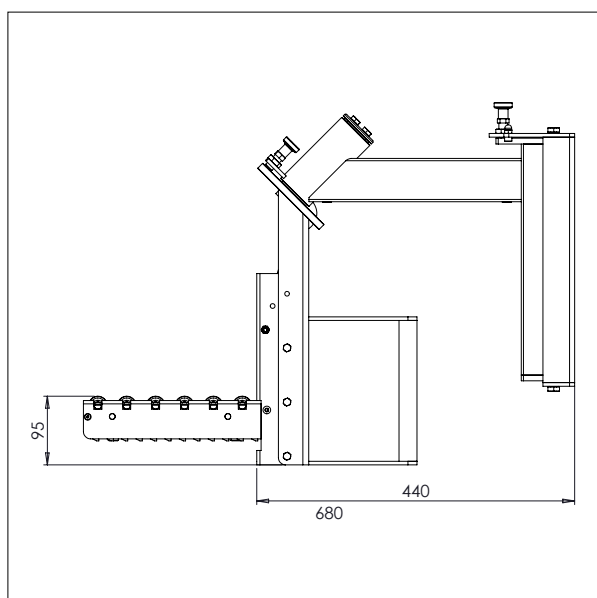
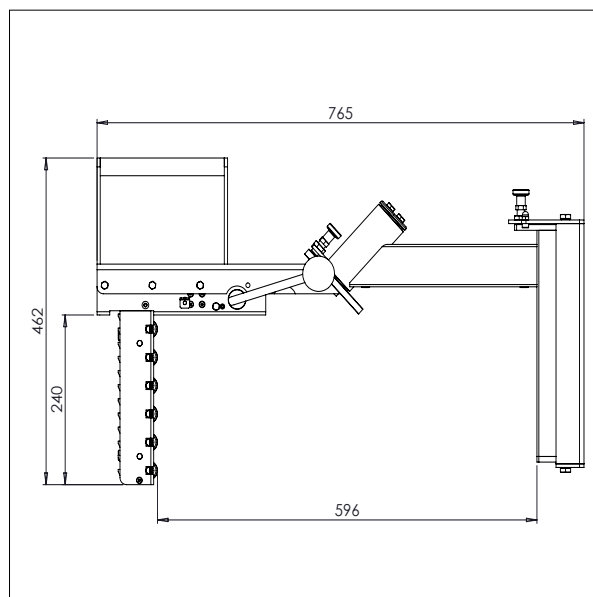
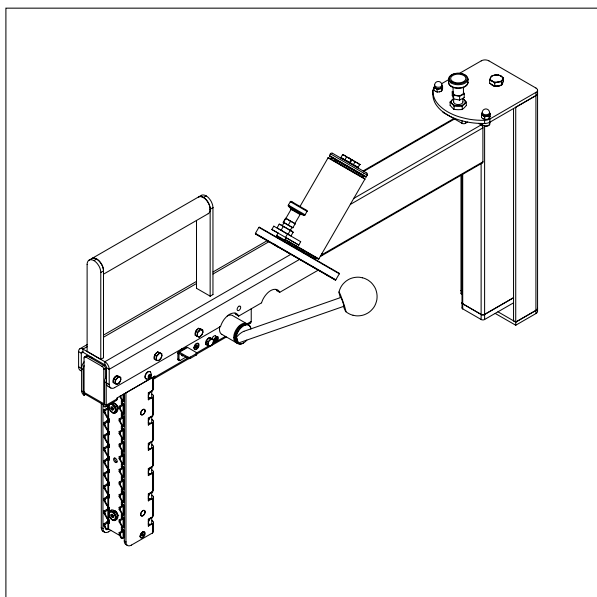

IMPACT 200 / TOOLS

MANDRIL ENLARGERS

- All measurements in mm

MANDRIL ENLARGER - CL1

For: $\varnothing 152$ mm/6"

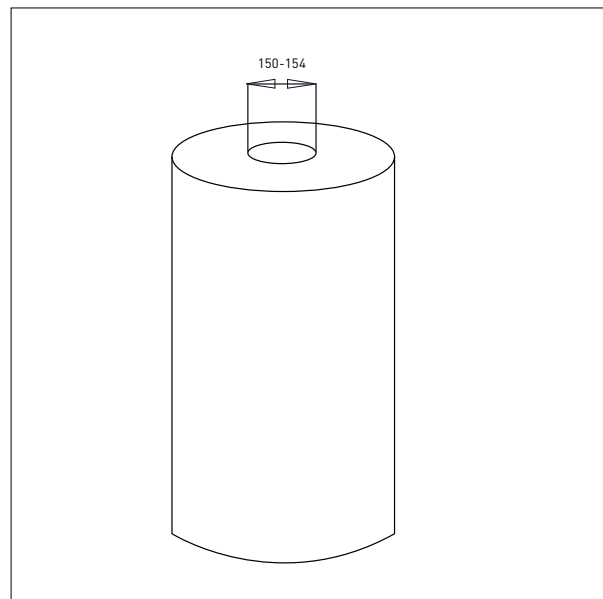
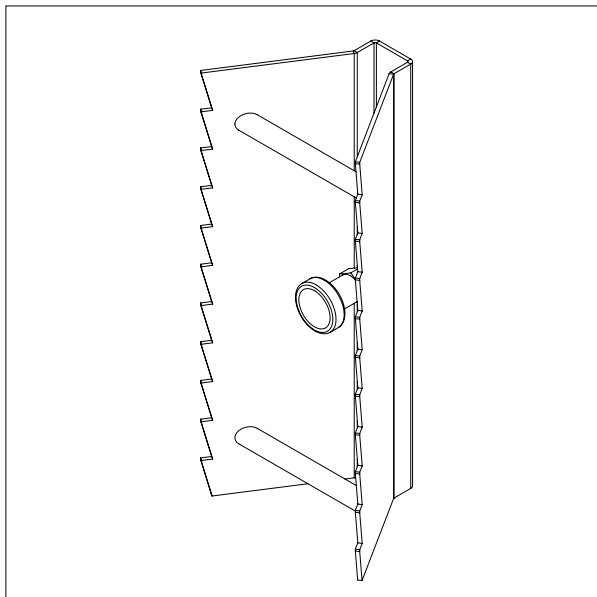

MANDRIL ENLARGER - CL2

For: $\varnothing 254$ mm/10"

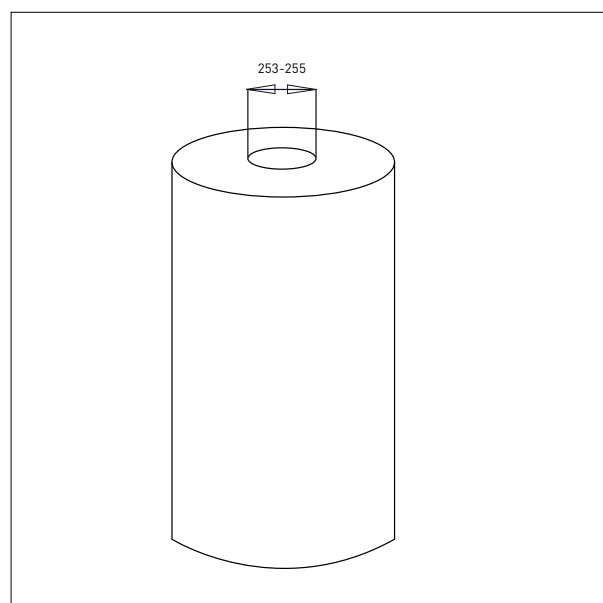
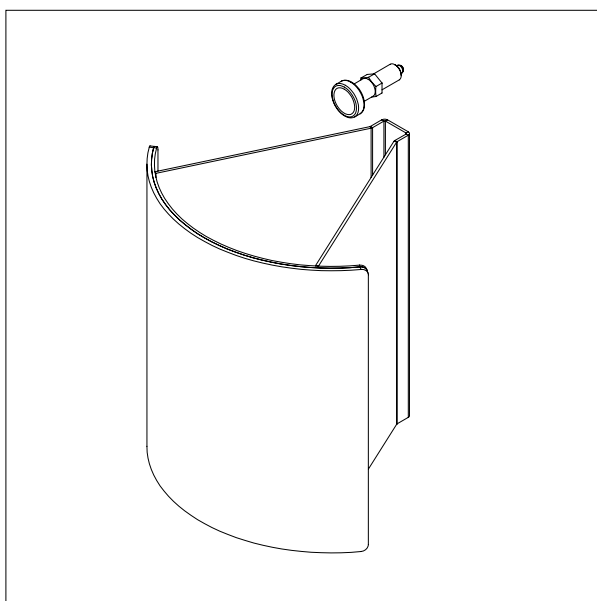

IMPACT 200 / ELECTRIC TOOLS

REEL MANIPULATOR

- All measurements in mm

REEL MANIPULATOR - VER

Reel manipulator – Full Electric Reel Manipulator

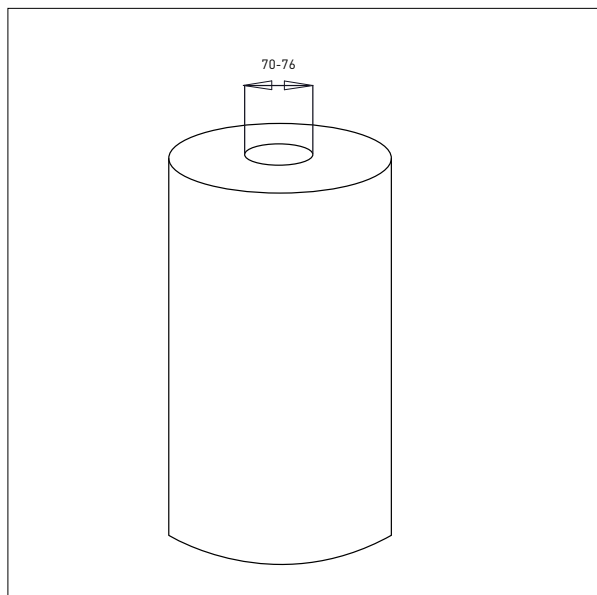
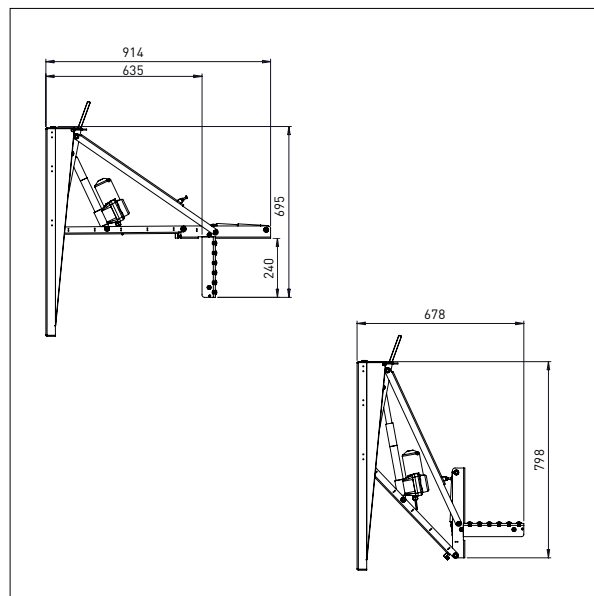
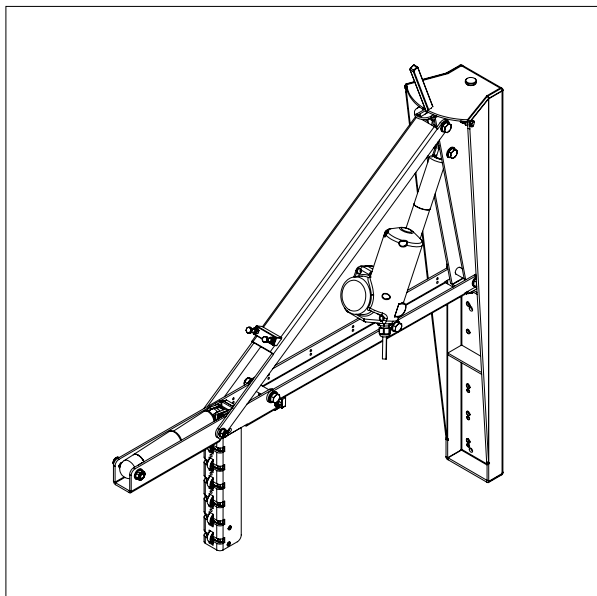

IMPACT 200 / ELECTRIC TOOLS

QUICK CLAMP

- All measurements in mm

QUICK CLAMP – QC6

Quick Clamp – with turning function

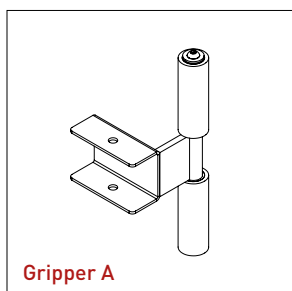
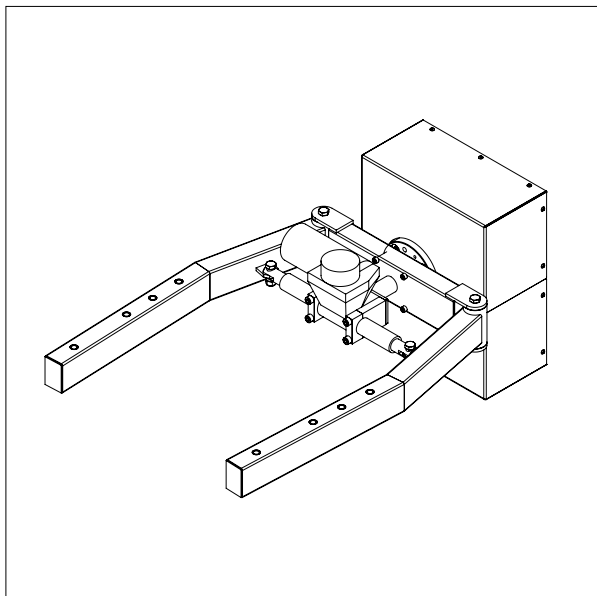

Gripper A

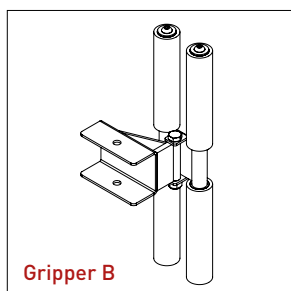

Gripper B

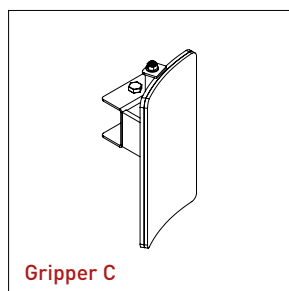

Gripper C

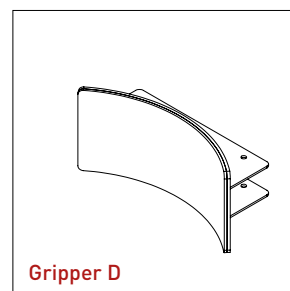

Gripper D

IMPACT 200 / ELECTRIC TOOLS

LINEAR GRIPPING

- All measurements in mm

LINEAR CLAMP – EG8

Linear Gripper – with tipping function

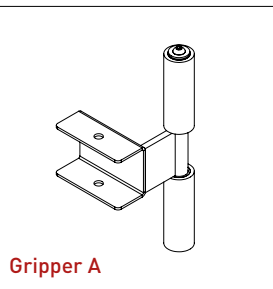
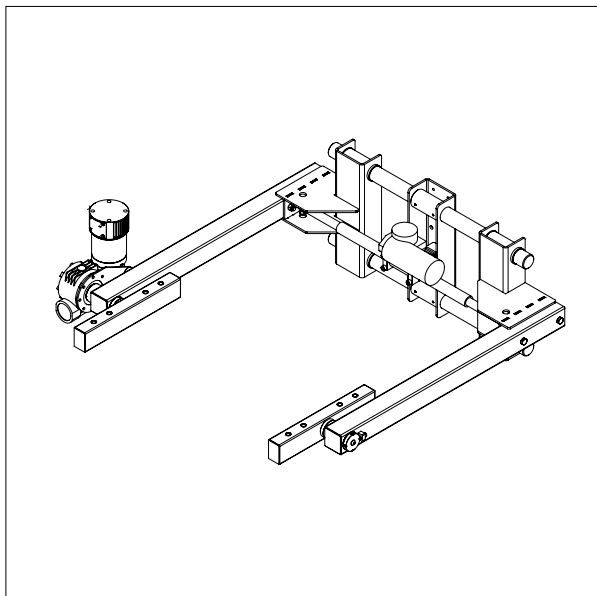

Gripper A

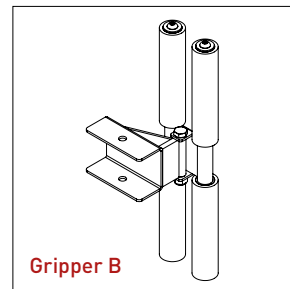

Gripper B

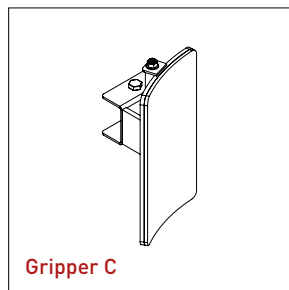

Gripper C

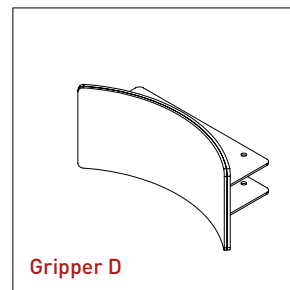

Gripper D

LINEAR CLAMP – EG6

Linear Gripper – with turning function

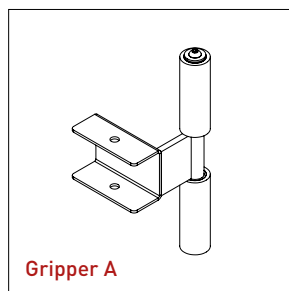
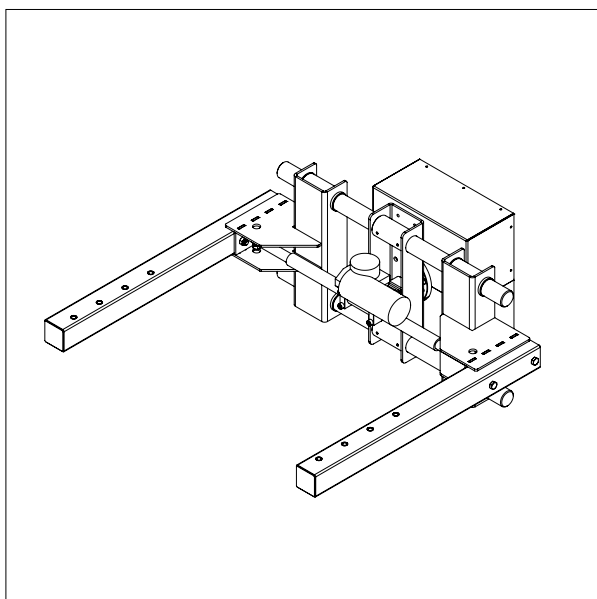

Gripper A

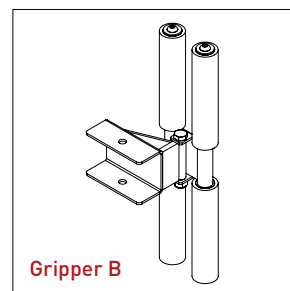

Gripper B

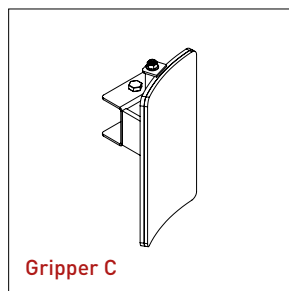

Gripper C

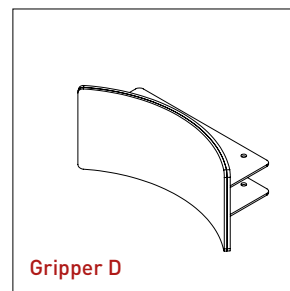

Gripper D