

IMPACT 80 LIFTERS & TOOLS

- DRAWINGS & MEASUREMENTS

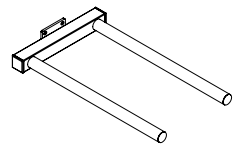
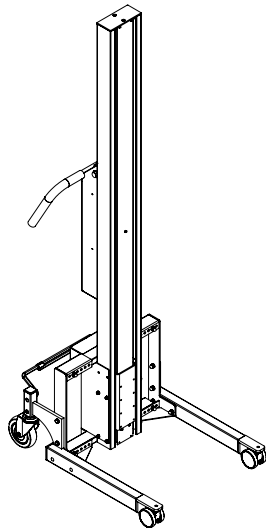
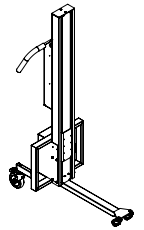
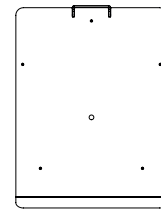
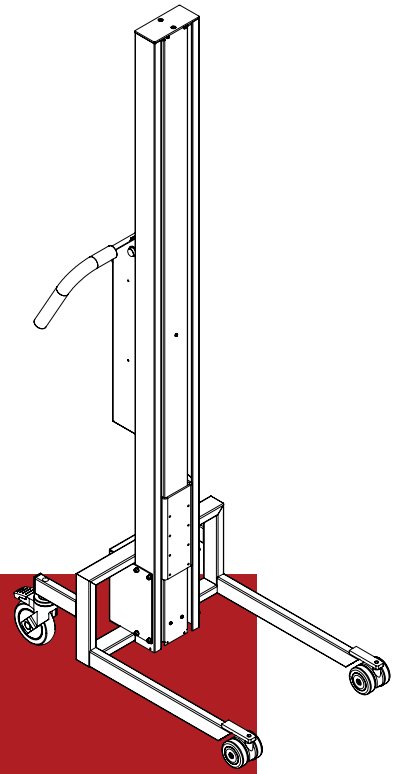

HOVMAND
LIFTING & MOVING TECHNOLOGY

IMPACT 80

2 MAST HEIGHTS AND 15 LEG/WHEEL OPTIONS

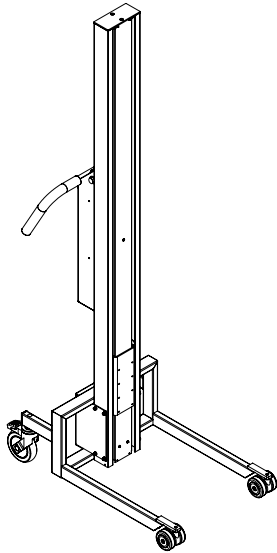

80 L/M standard legs

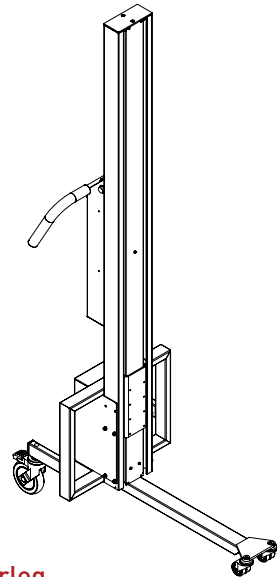

80 L/M Centerleg

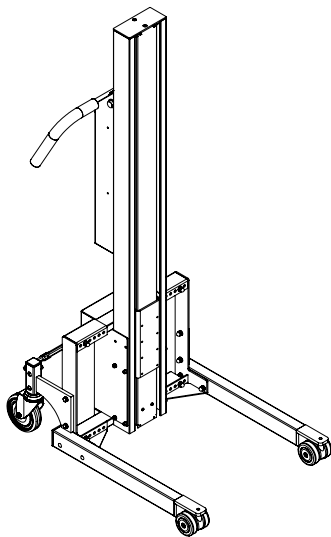

80 L/M FC - Flexleg type 1

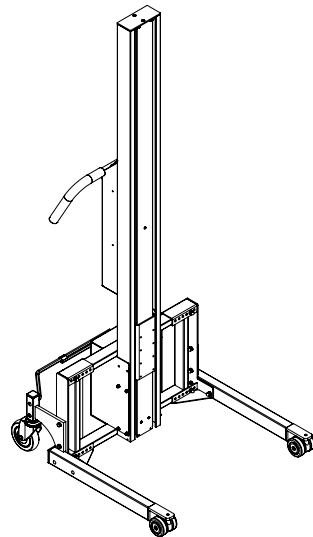

80 L/M FC - Flexleg type 2

IMPACT 80

LIFTERS - DRAWINGS & MEASUREMENTS

- All measurements in mm

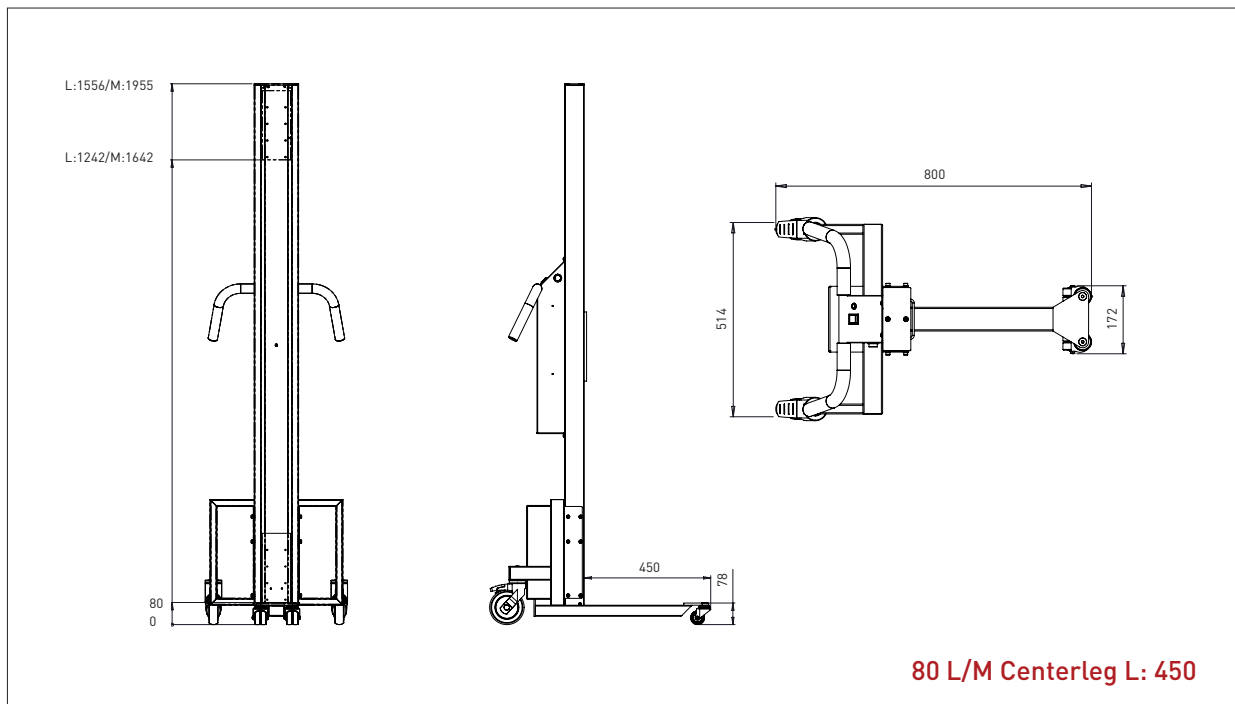
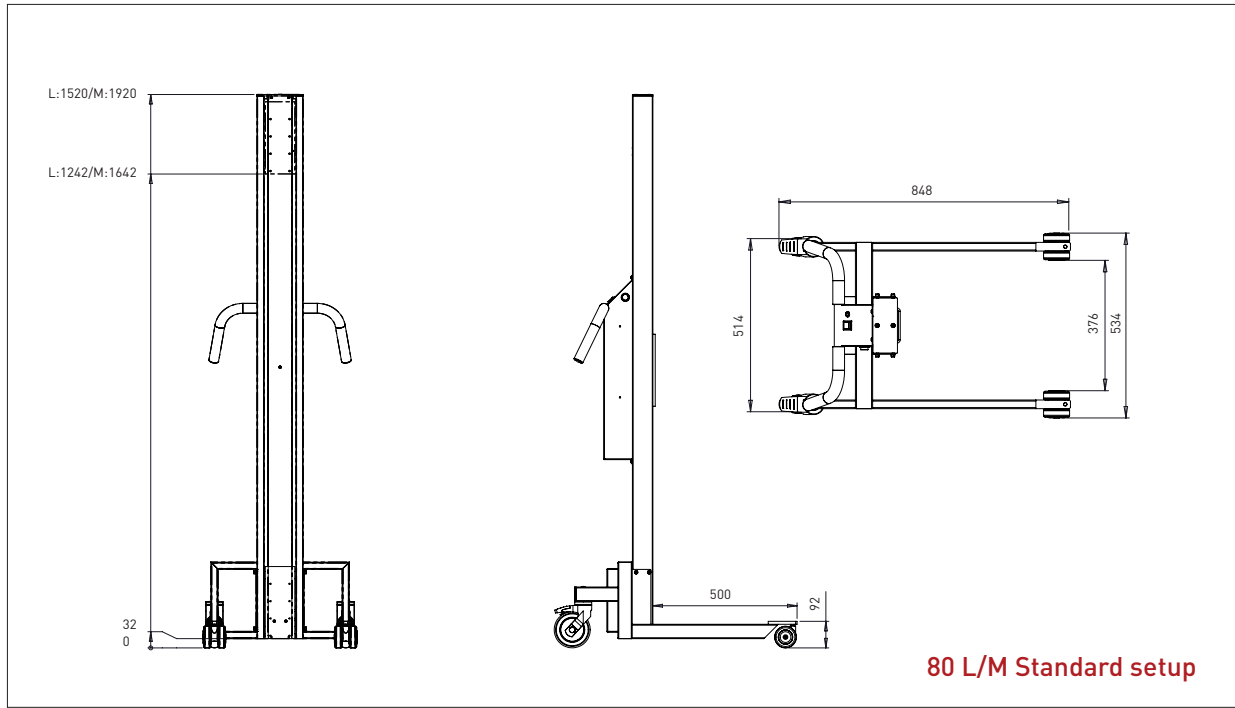

IMPACT 80

LIFTERS - DRAWINGS & MEASUREMENTS

- All measurements in mm

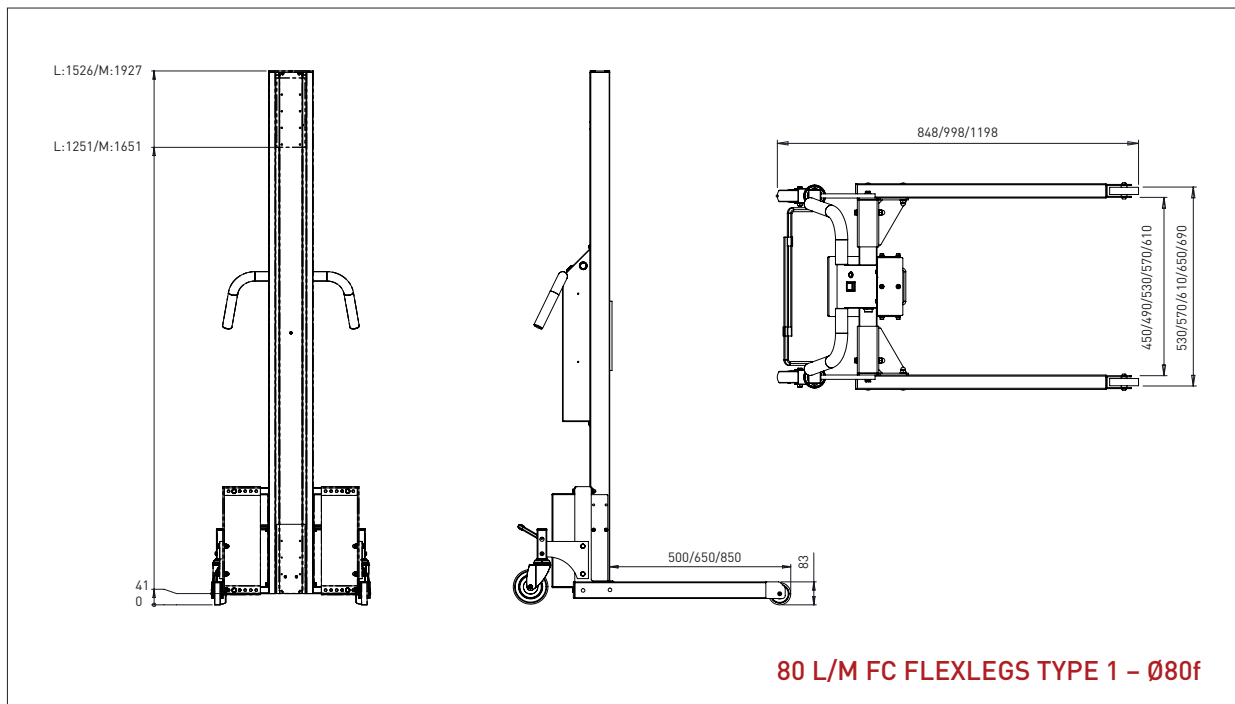
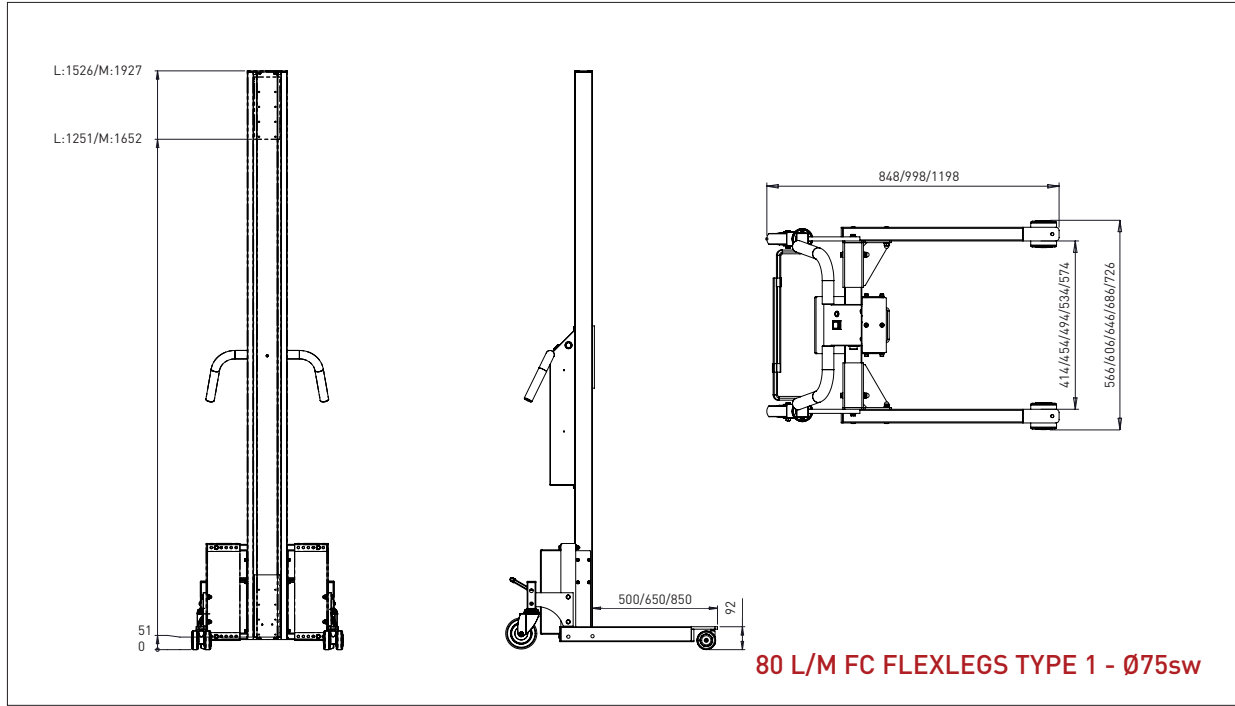

IMPACT 80

LIFTERS - DRAWINGS & MEASUREMENTS

- All measurements in mm

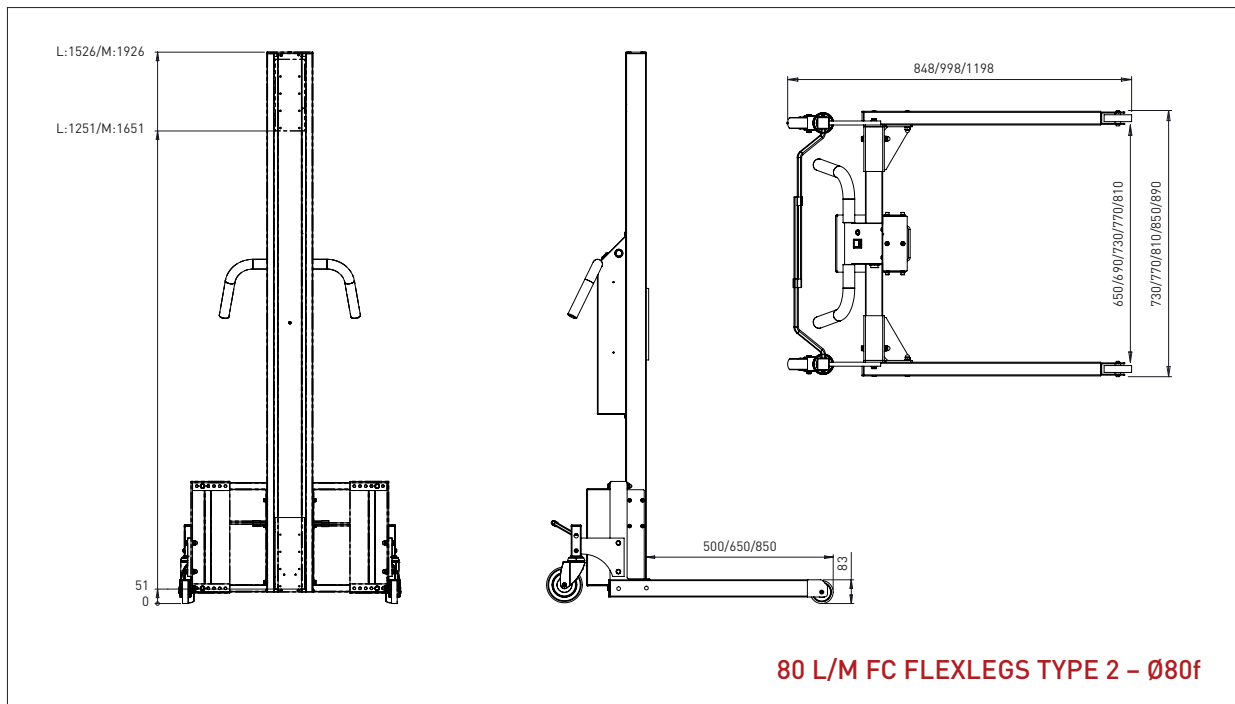
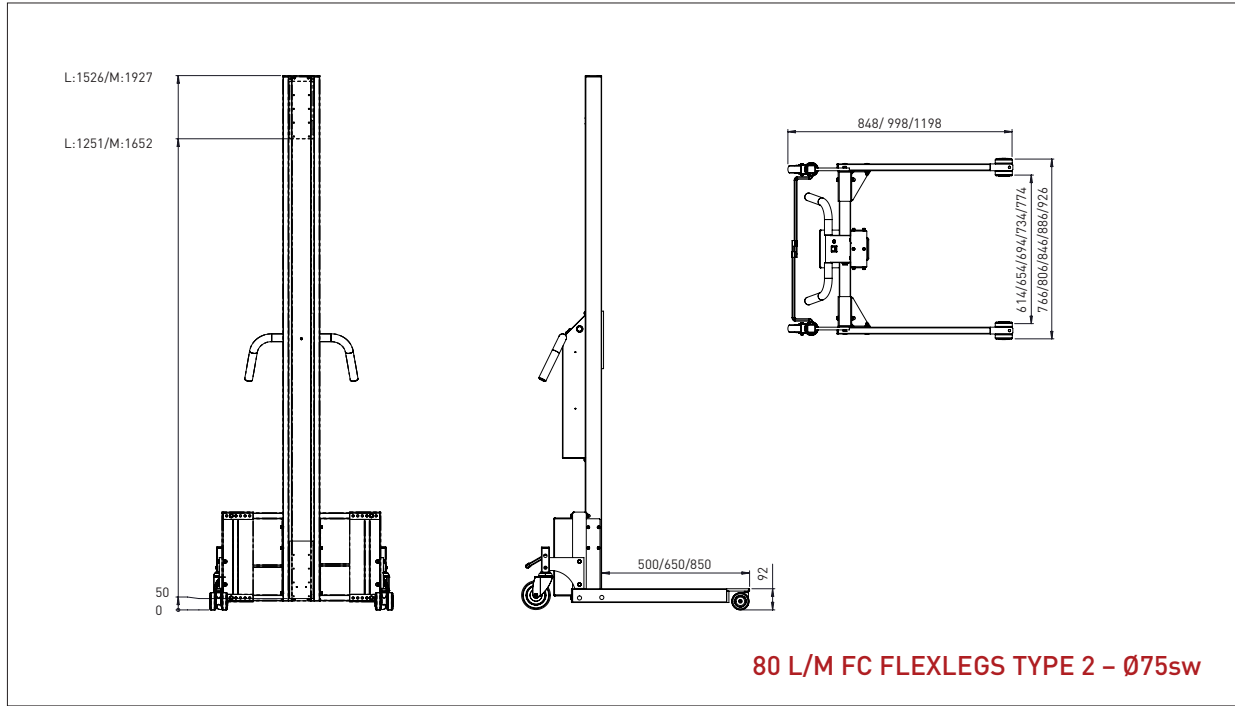

IMPACT 80 / TOOLS

PLATFORM WOOD

- All measurements in mm

PLATFORM WOOD – W1

L x W: 400 x 450 mm

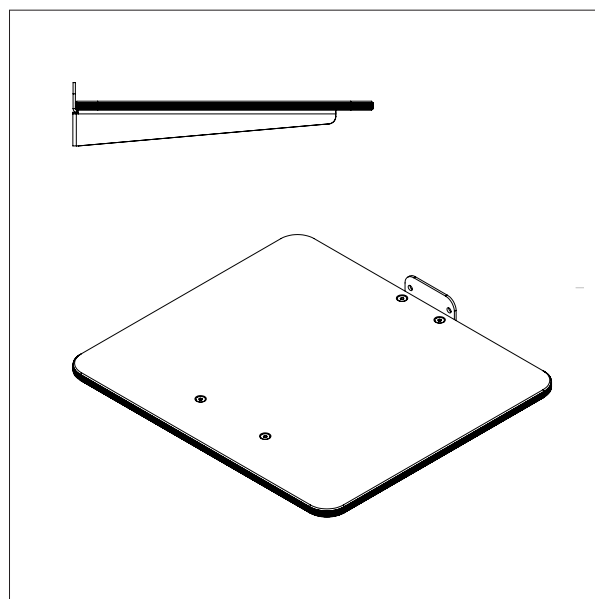
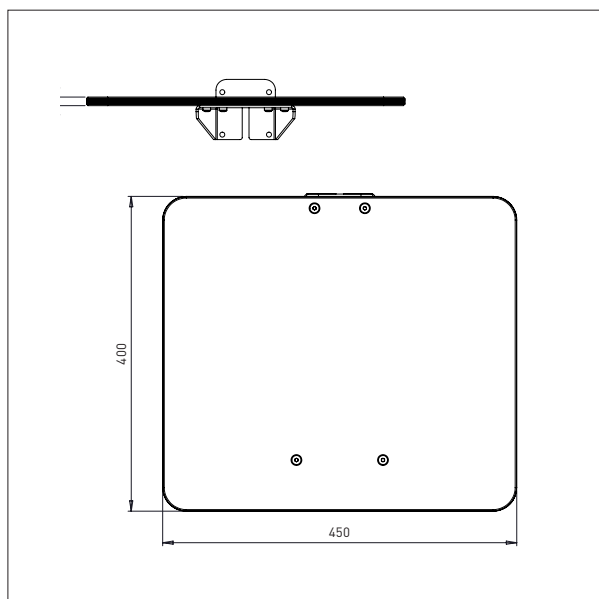

PLATFORM WOOD – W2

L x W: 500 x 500 mm

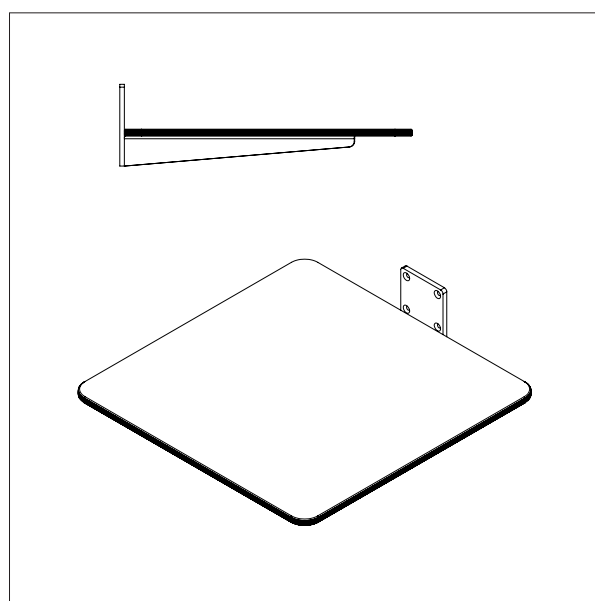
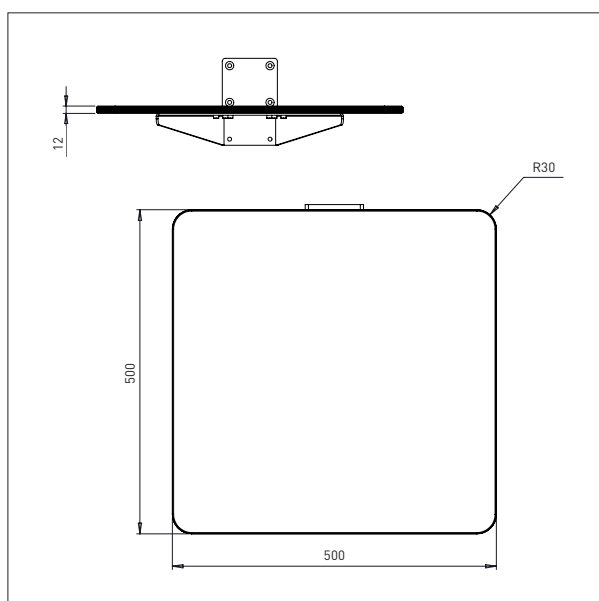

IMPACT 80 / TOOLS

PLATFORM WOOD

- All measurements in mm

PLATFORM WOOD – W3

L x W: 600 x 600 mm

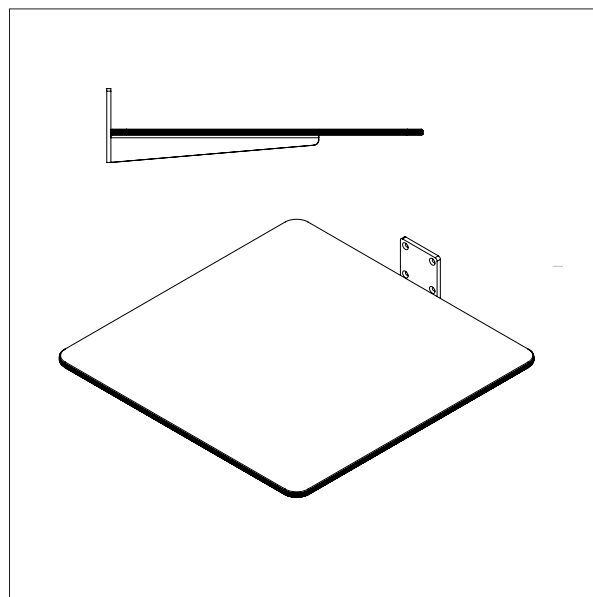
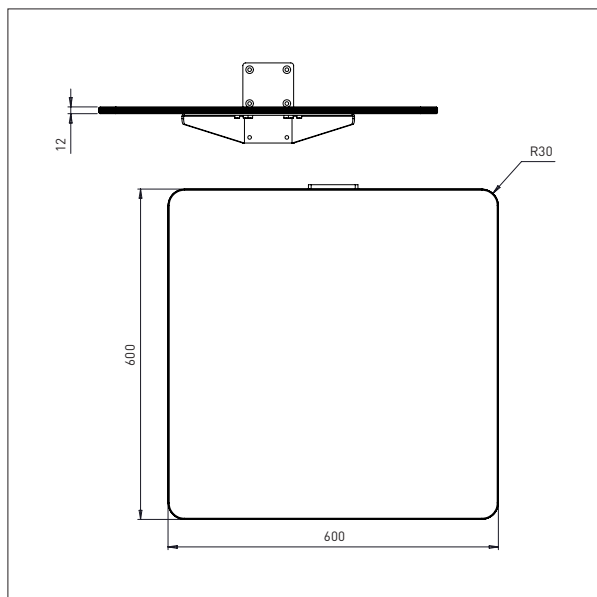

PLATFORM WOOD WITH ROLLER – W4

L x W: 500 x 500 mm

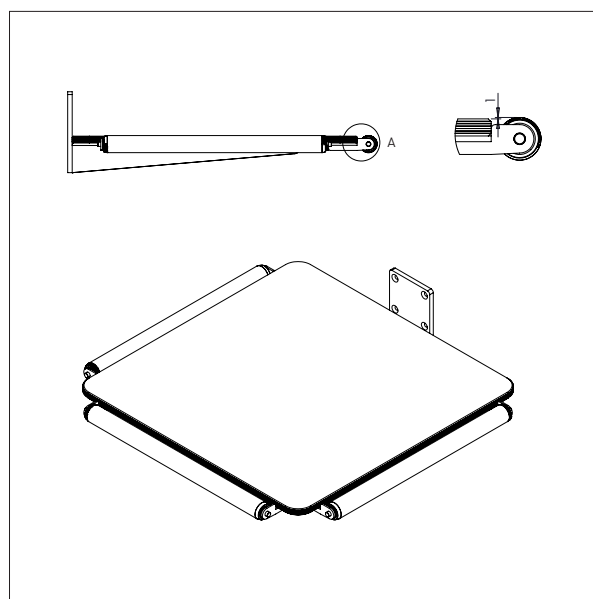
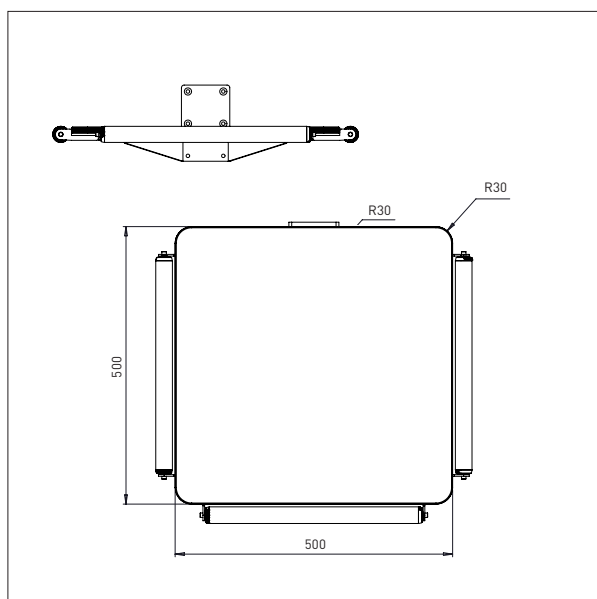

IMPACT 80 / TOOLS

PLATFORM PEHD (PLASTIC)

- All measurements in mm

PLATFORM PEHD – KP1

L x W: 495 x 495 mm

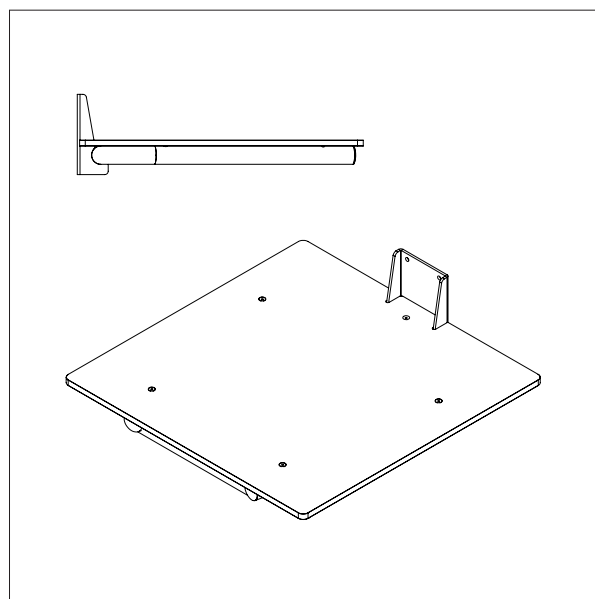
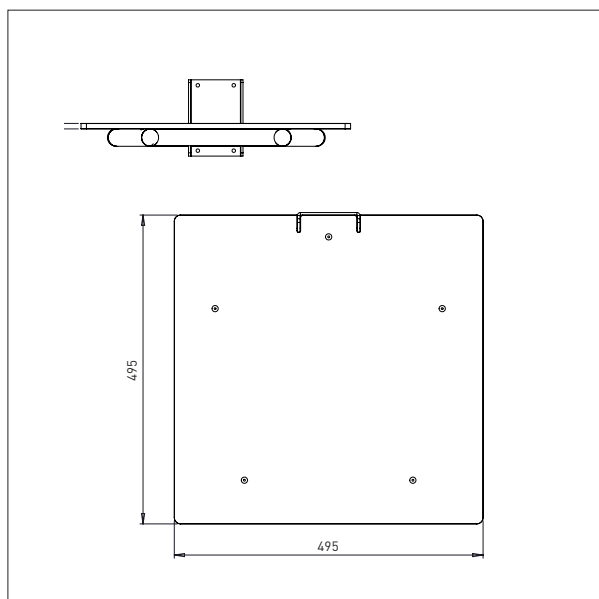

PLATFORM PEHD – KP2

L x W: 600 x 600 mm

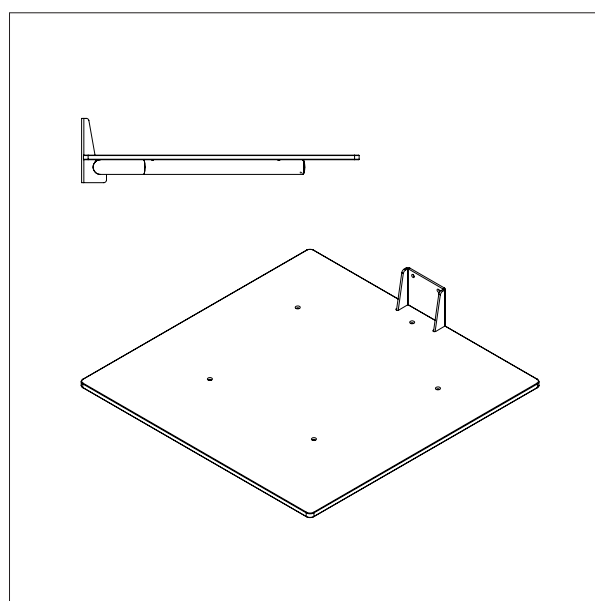
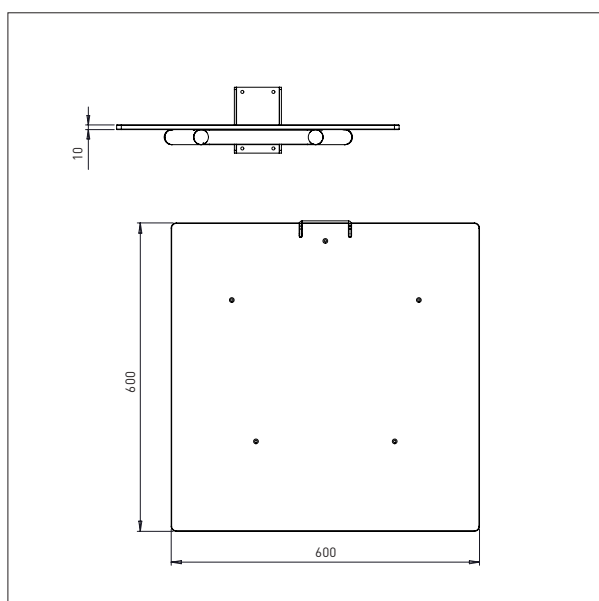

IMPACT 80 / TOOLS

PLATFORM PEHD (PLASTIC)

- All measurements in mm

PLATFORM PEHD WITH ROLLER - KP3

L x W: 495 x 495 mm

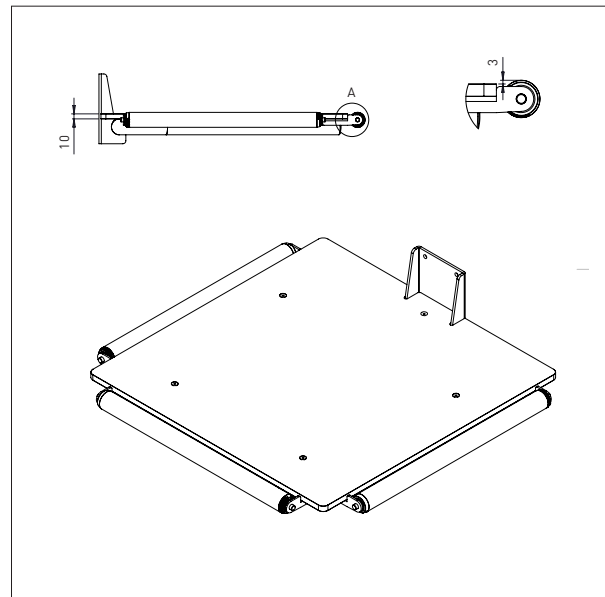
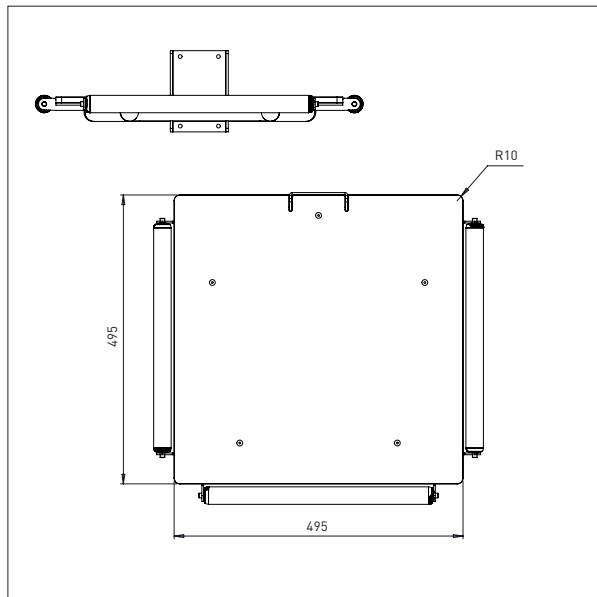

IMPACT 80 / TOOLS

PLATFORM STAINLESS

- All measurements in mm

PLATFORM STAINLESS – EP1

L x W: 500 x 400 mm

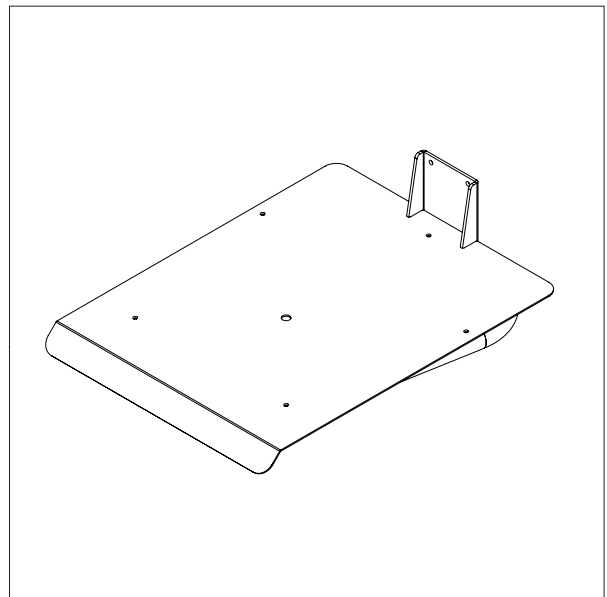
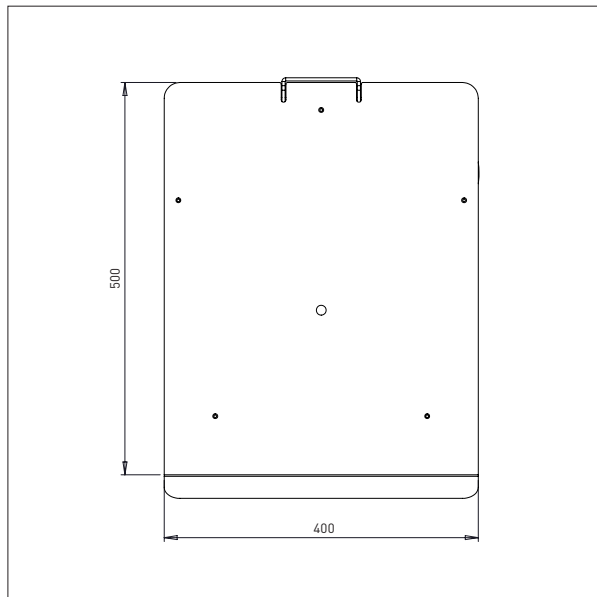

PLATFORM STAINLESS – EP2

L x W: 500 x 500 mm

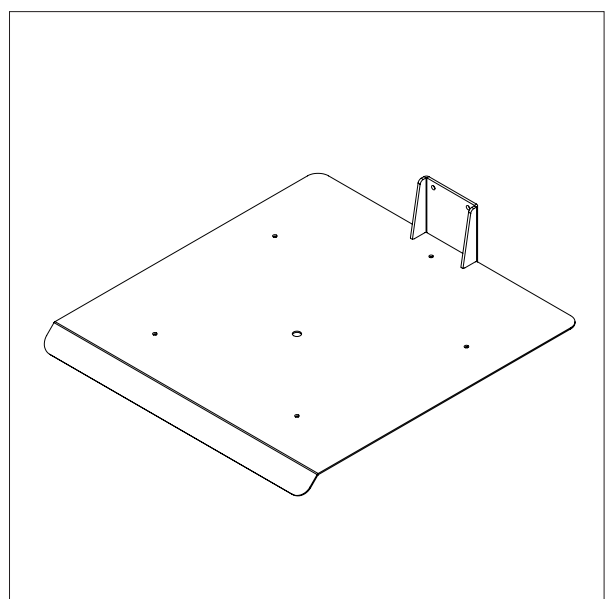
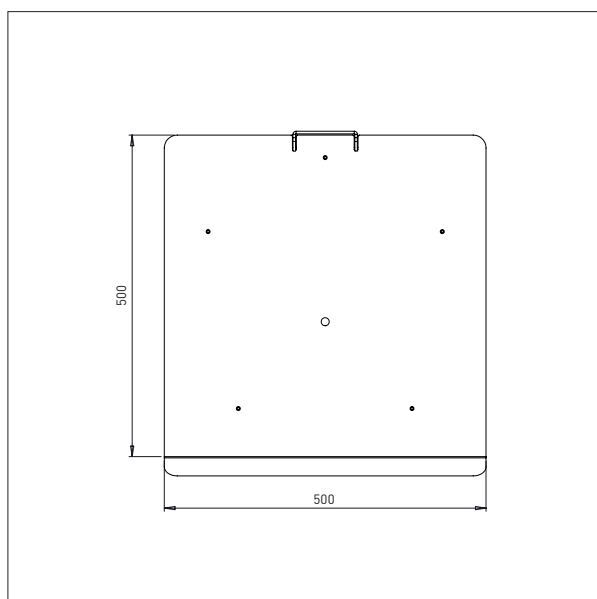

IMPACT 80 / TOOLS

BOOM

- All measurements in mm

BOOM - D1

Ø x L: 60 x 500 mm

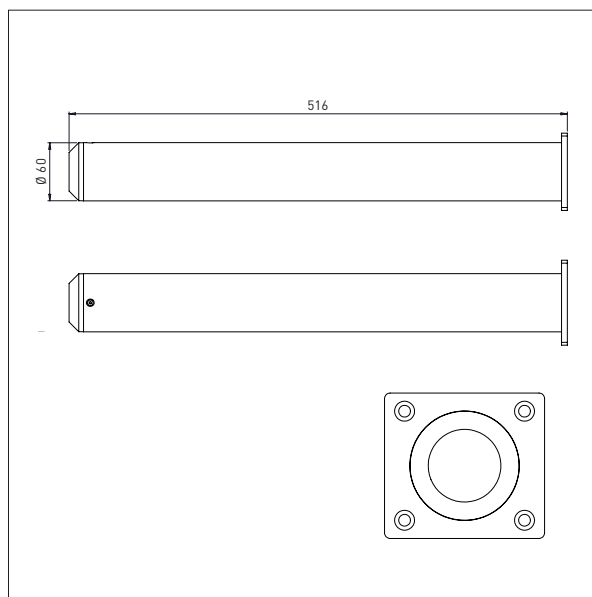
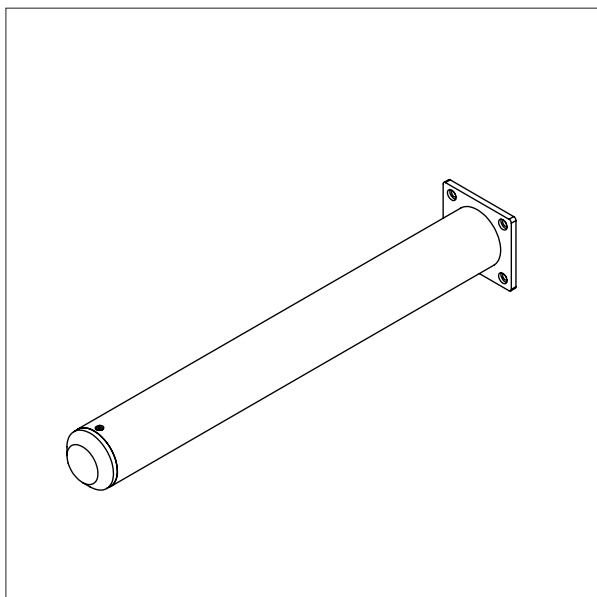

BOOM - D2

Ø x L: 60 x 800 mm

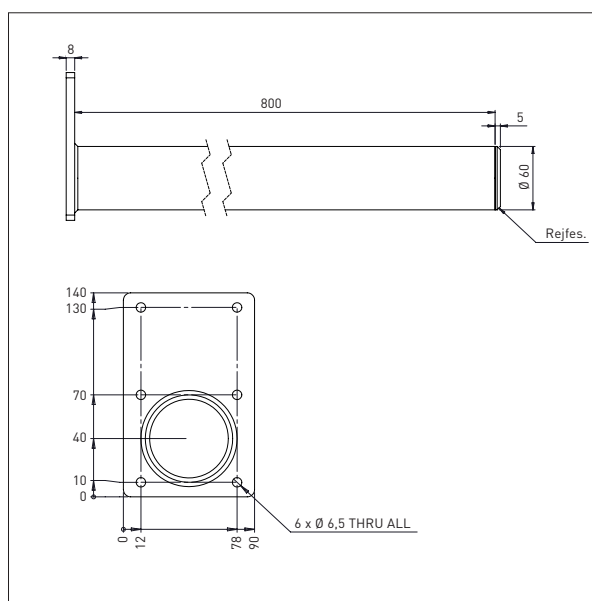
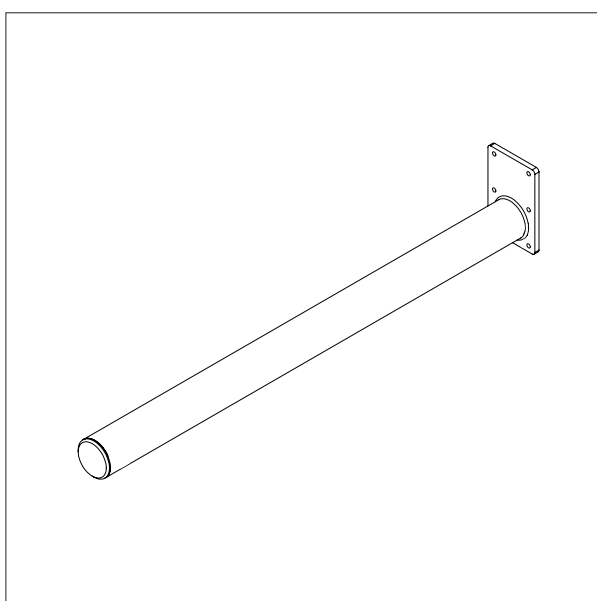

IMPACT 80 / TOOLS

DOUBLE BOOM

- All measurements in mm

DOUBLE BOOM – DD1

Ø x L x W: 32 x 500 x 250 mm

Min. width of reel: Ø 300 mm

Max. width of reel: Ø 400 mm

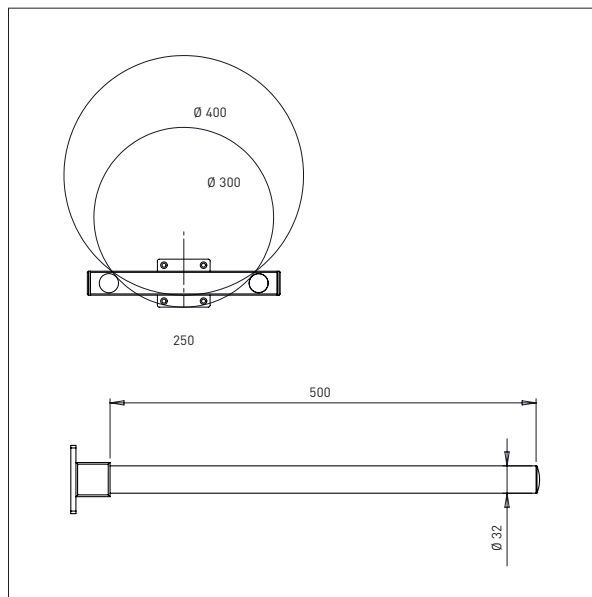
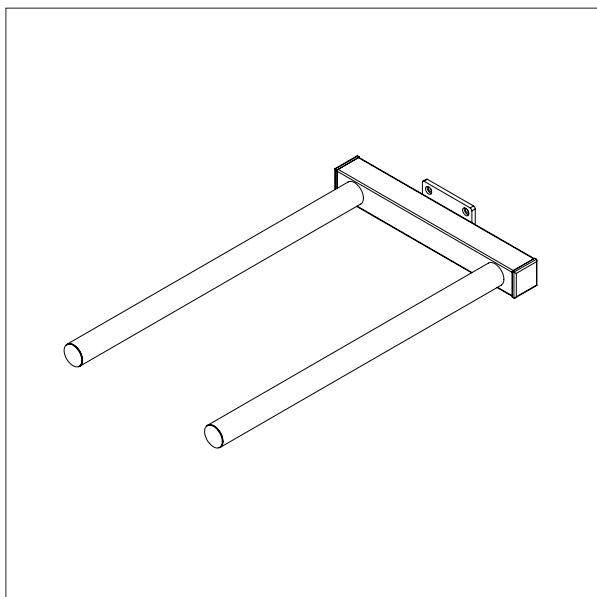

DOUBLE BOOM – DD2

Ø x L x W: 32 x 500 x 350 mm

Min. width of reel: Ø 400 mm

Max. width of reel: Ø 800 mm

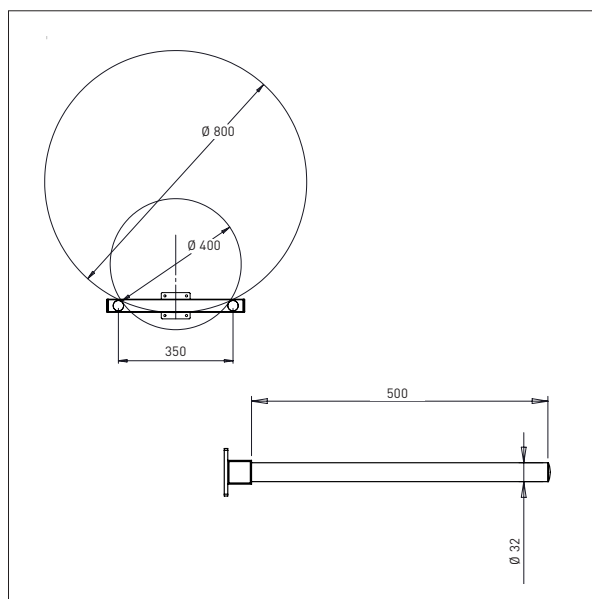
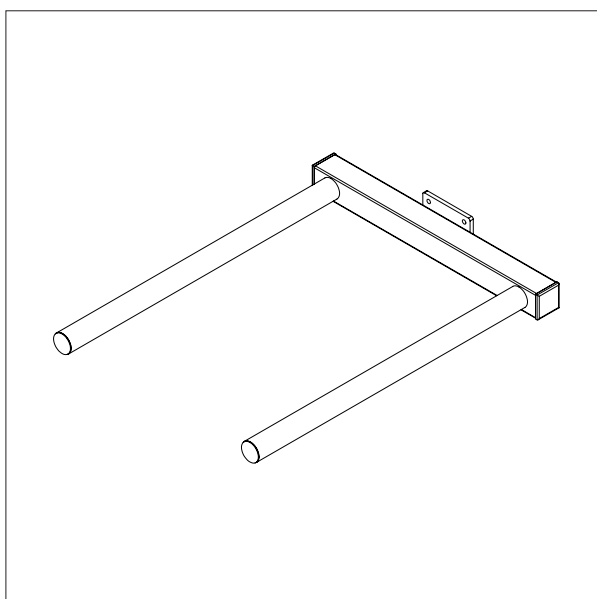

IMPACT 80 / TOOLS

FORK

- All measurements in mm

FORK - G1

L x W: 585 x 375 mm

For 600 x 400 mm boxes

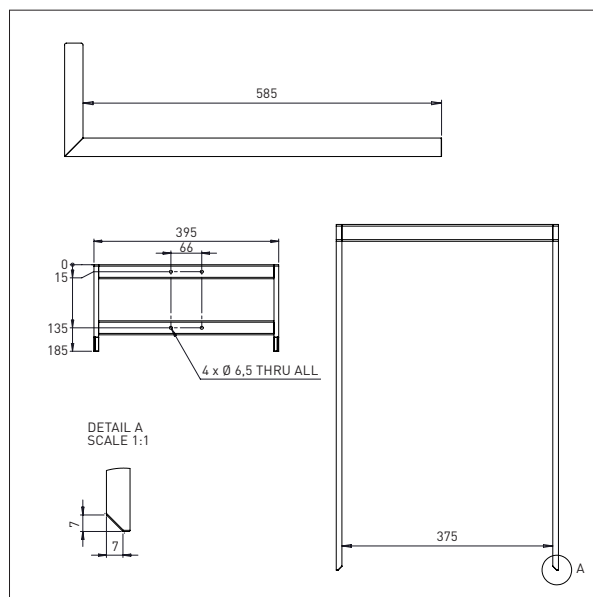
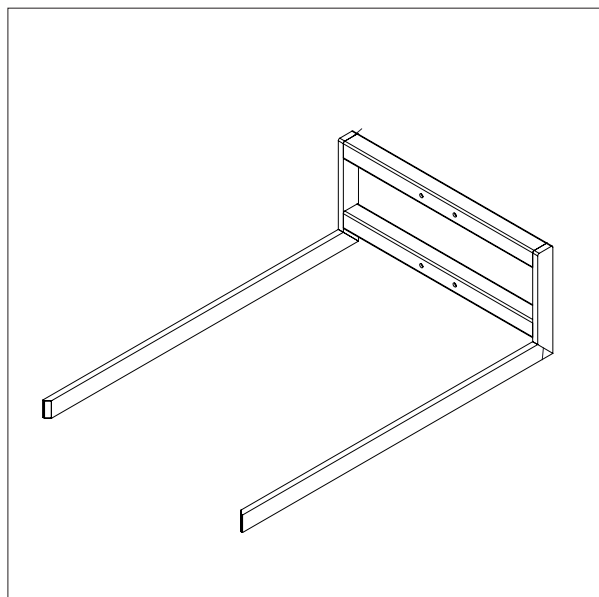

FORK - SLC

L x W: 600 x 410 mm

For 600 x 400 mm boxes

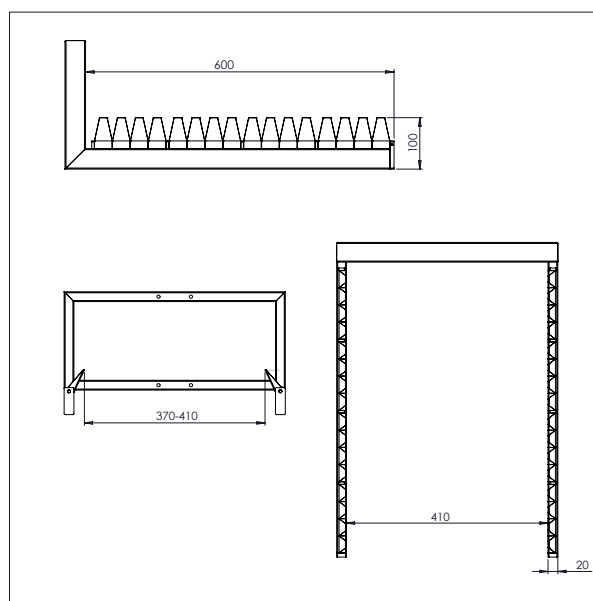
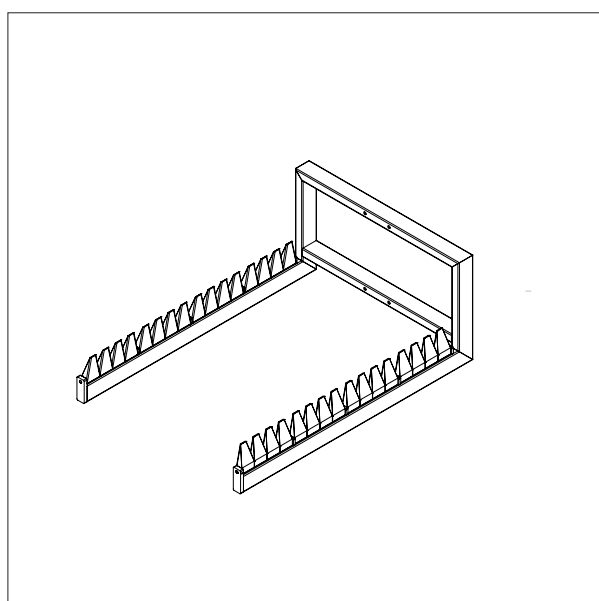

IMPACT 80 / TOOLS

BOOM + V-BLOCK

- All measurements in mm

BOOM + V-BLOCK – DVB1

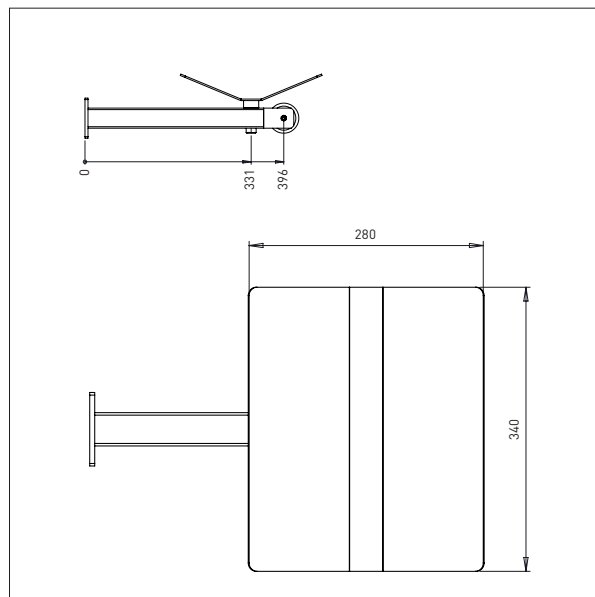
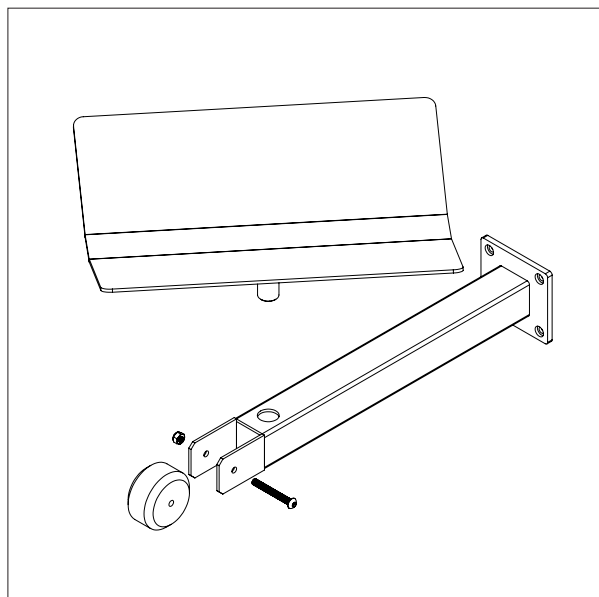

BOOM + V-BLOCK – DVB2

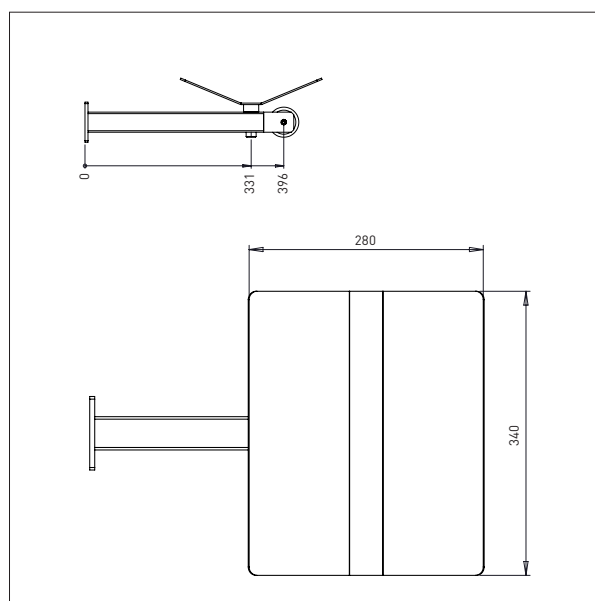
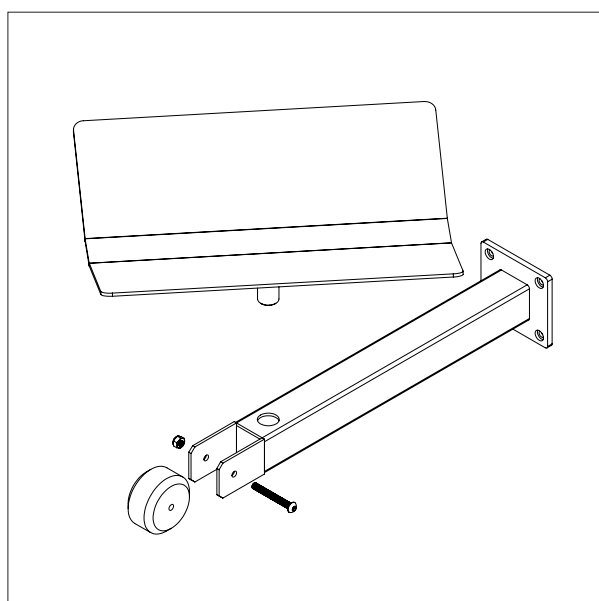

IMPACT 80 / TOOLS

PLATFORM + V-BLOCK

- All measurements in mm

PLATFORM + V-BLOCK - EPV

Platform: 500 x 400

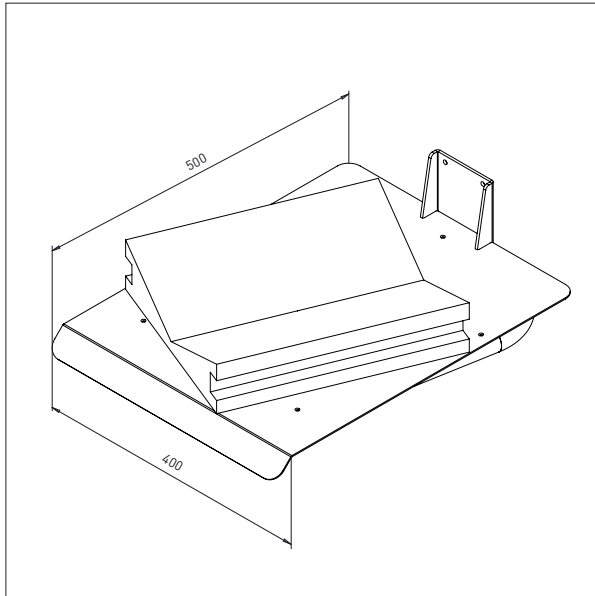

IMPACT 80 / TOOLS

CRANE ARM

- All measurements in mm

CRANE ARM - KA1

L: 600

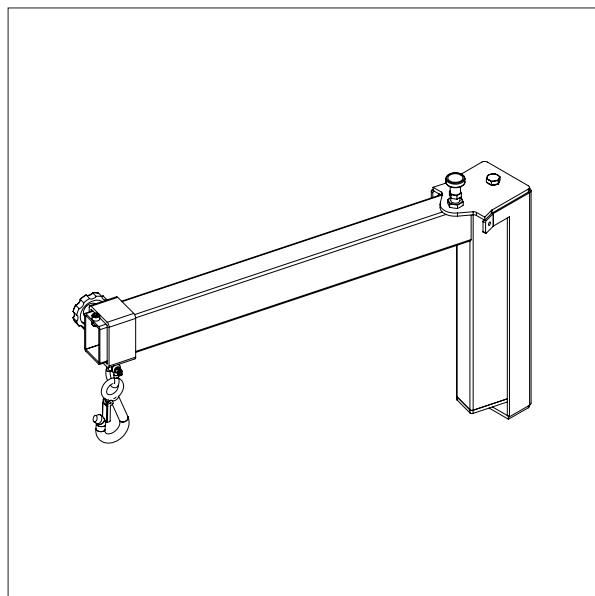
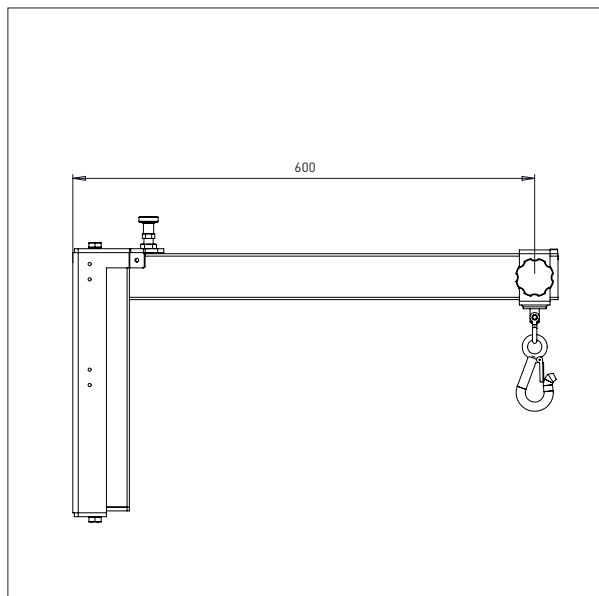

CRANE ARM - KA2

L: 800

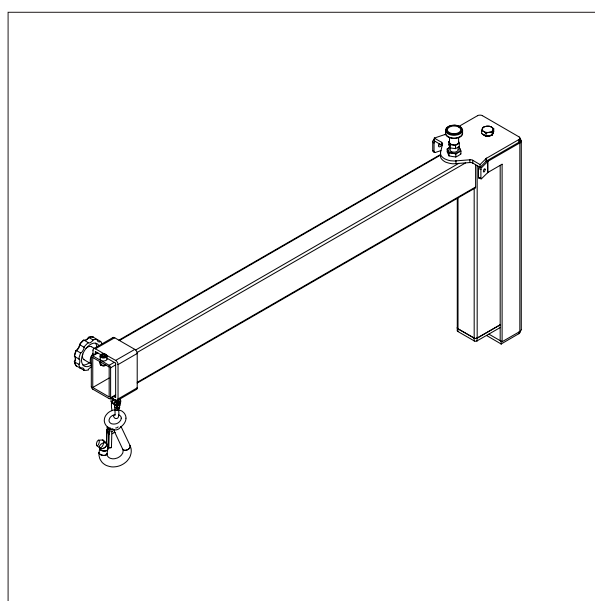
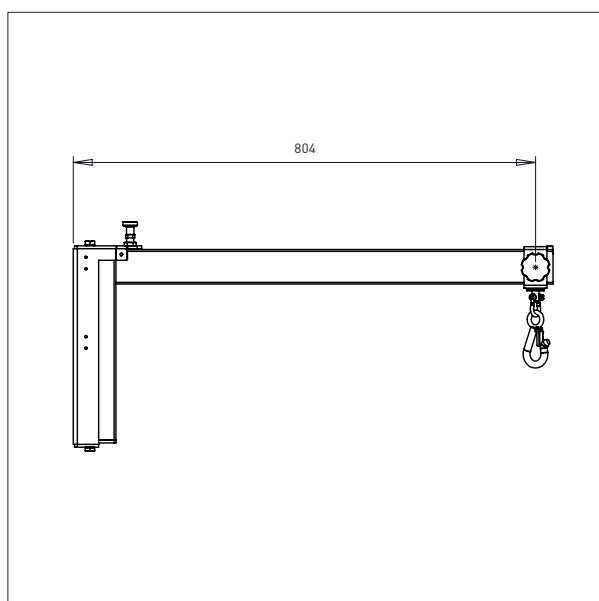

IMPACT 80 / TOOLS

TUBE

- All measurements in mm

TUBE

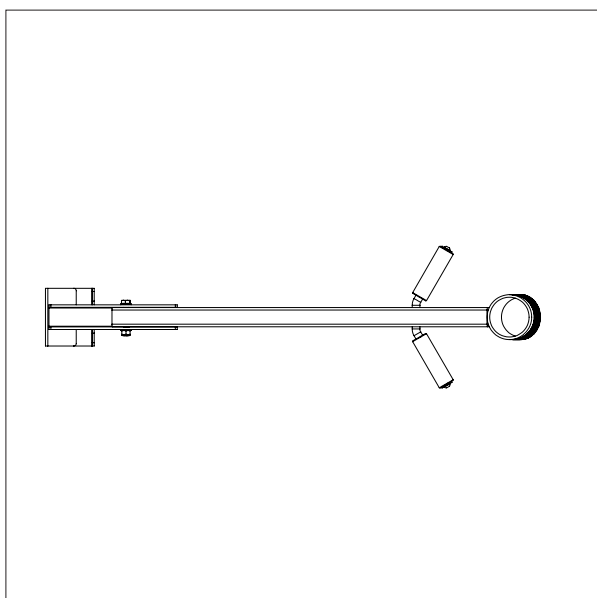
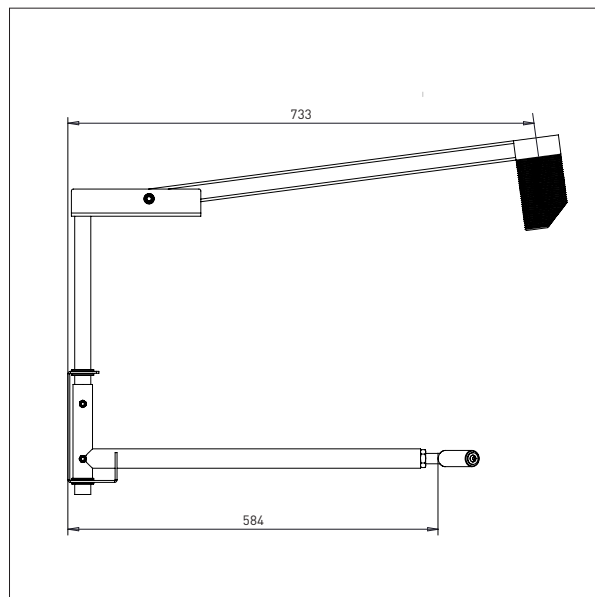
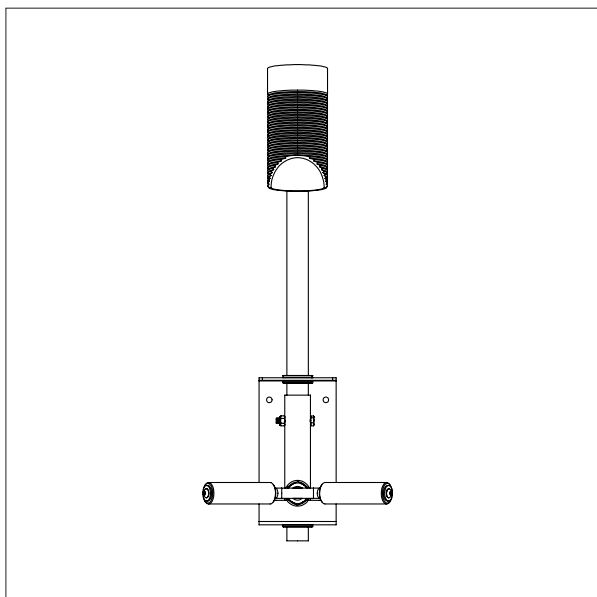

IMPACT 80 / TOOLS

REEL MANIPULATOR

- All measurements in mm

REEL MANIPULATOR - MRP1

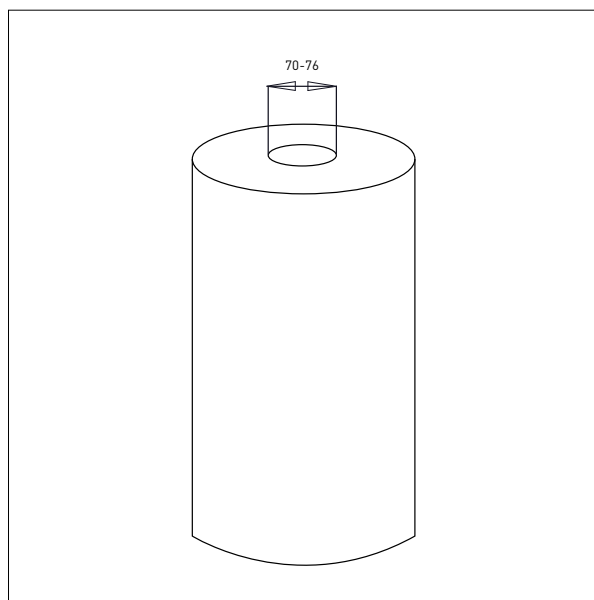
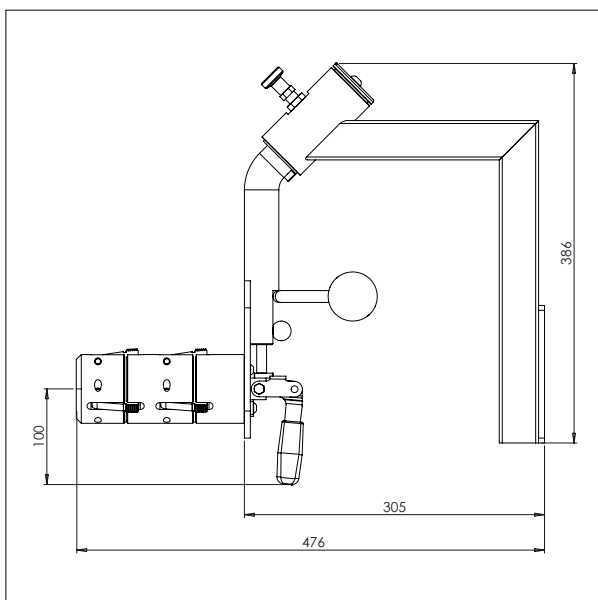
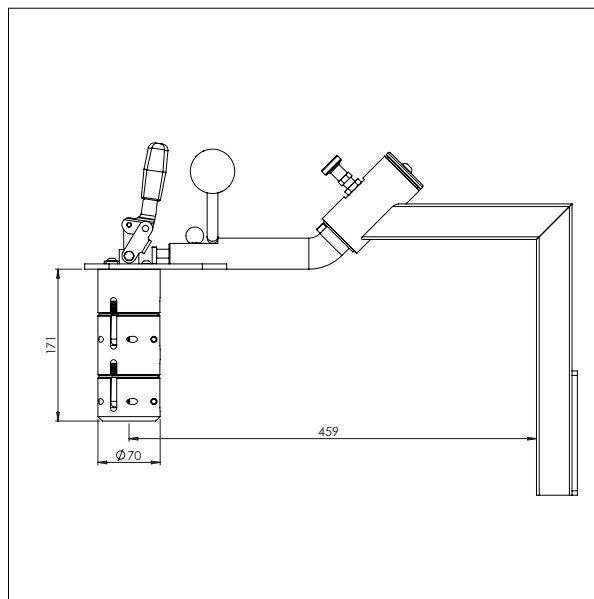
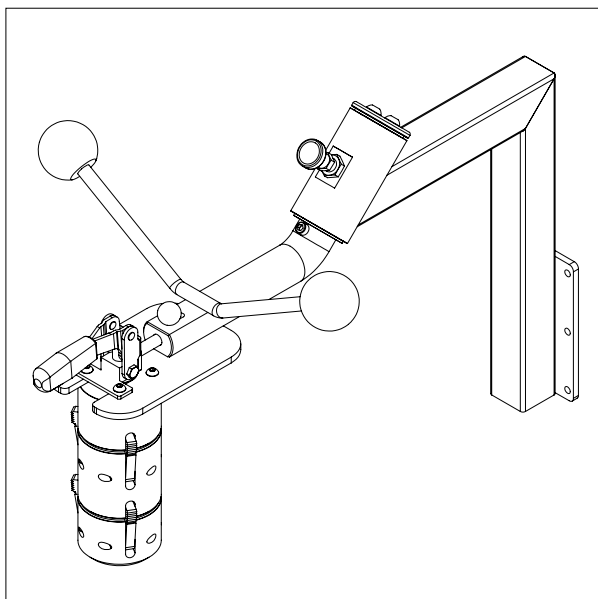

IMPACT 80 / TOOLS

REEL MANIPULATOR

- All measurements in mm

REEL MANIPULATOR - MRP2

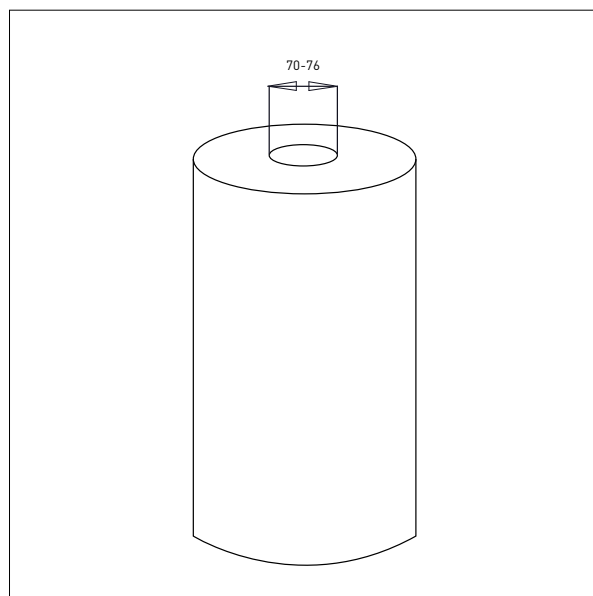
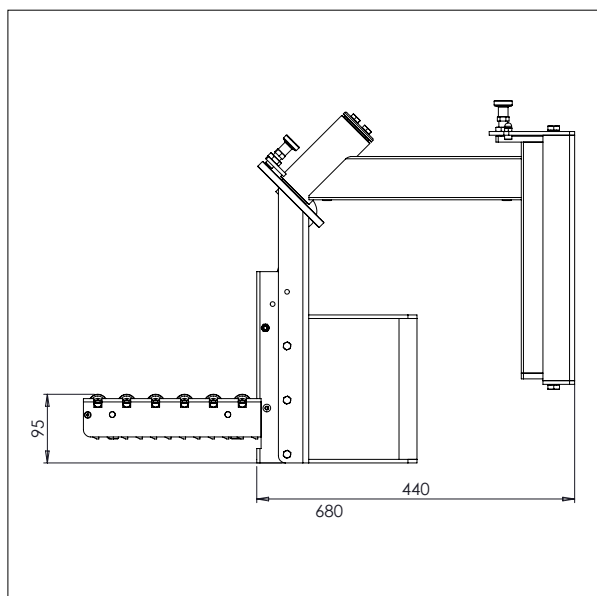
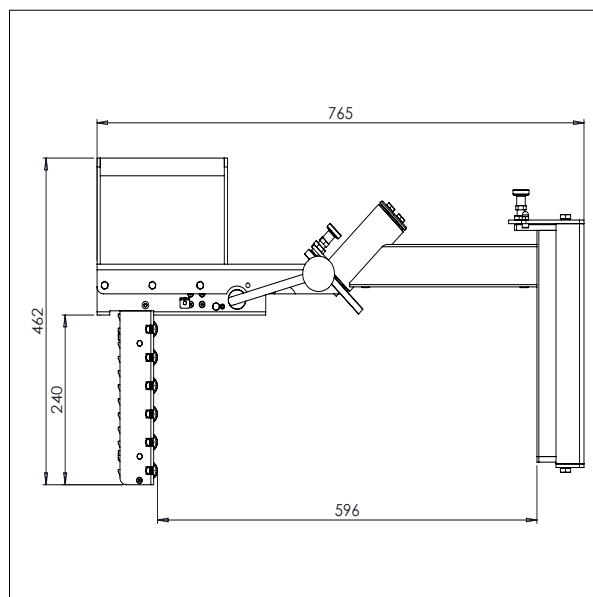
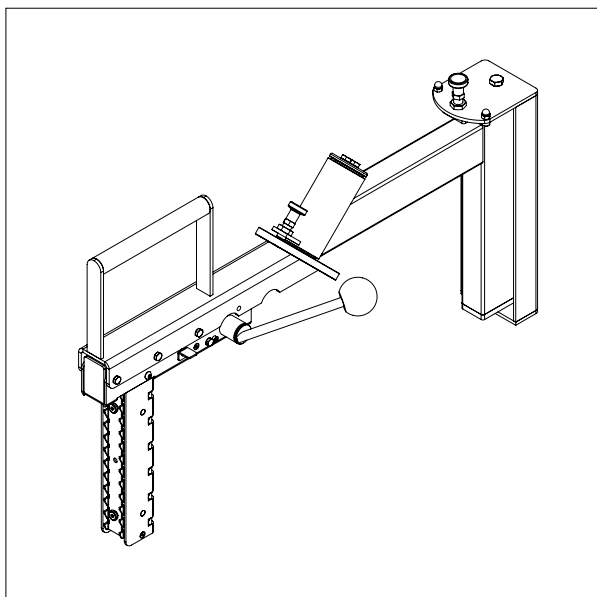

IMPACT 80 / TOOLS

MANDRIL ENLARGER

- All measurements in mm

MANDRIL ENLARGER - CL1

For: $\varnothing 152 \text{ mm}/6''$

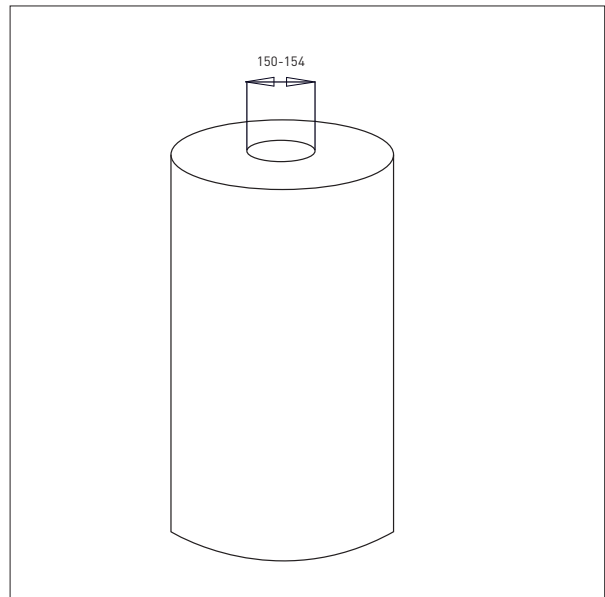
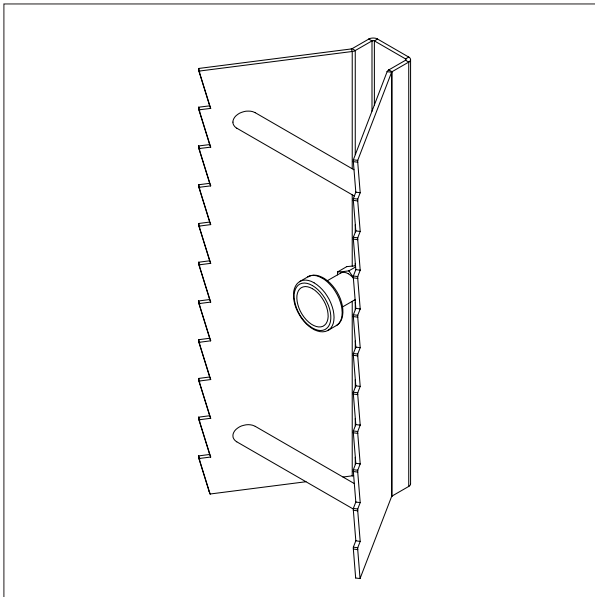

MANDRIL ENLARGER - CL2

For: $\varnothing 254 \text{ mm}/10''$

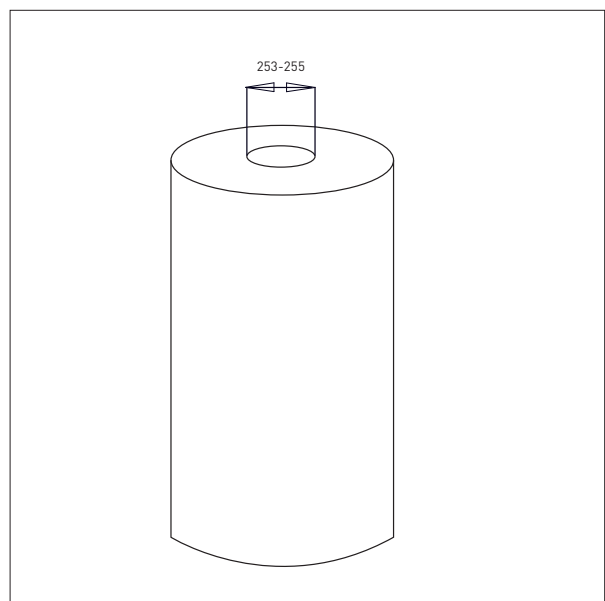
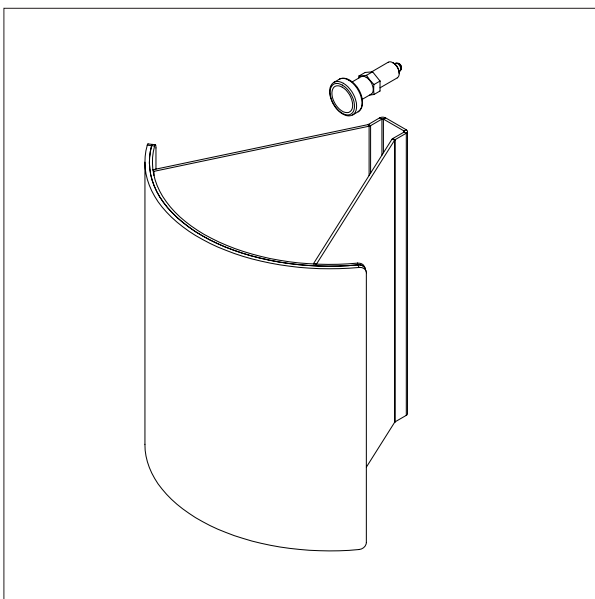

IMPACT 80 / TOOLS

REEL MANIPULATOR

- All measurements in mm

REEL MANIPULATOR - MRP3

