



PRODUCT & TECHNICAL GUIDE

PAVING STONES AND RETAINING WALLS







Keystone Hardscapes is built on a commitment to service and our customers. We work tirelessly to create products that deliver the highest value and endless design possibilities.

With Keystone Hardscapes, you and your family will experience an uncompromising level of quality and craftsmanship. Our pavers and wall stones were designed to add beauty, function and to stand the test of time.

Our product styles, shapes, unique colors and textures will allow you to bring out the very best in your hardscape design. Whether you're creating a backyard sanctuary to relax and recharge, a gathering space to entertain family and friends, a stunning driveway and walkways to make a great first impression... you're sure to find a Keystone Hardscapes product that fits your lifestyle.

Member:



Connect with us: [f](#) [t](#) [v](#) [p](#) [i](#) [n](#)

INDEX

STANDARD 60MM PAVERS

Bullnose.....	4
CityStone™.....	5
Classic Brick.....	6
Contempra®.....	7
Holland Stone.....	8
Munich™ Series.....	9
Panorama™.....	10
Panorama™ Circle.....	11
Roman Cobble®.....	12
Cobble Circle.....	13

STANDARD 70MM PAVERS

Vienna Classic™.....	14
Villa Grande Series®.....	15

STANDARD 80MM PAVERS

Holland Stone.....	16
Roman Cobble®.....	16

STANDARD 100MM PAVERS

CityLock®.....	17
----------------	----

PERMEABLE PAVERS

Eco-CityLock®.....	18
Eco-Panorama™.....	19
Eco-Venetian®.....	20
Roman Cobble® Green.....	21
Turfstone.....	22

Overview for Paving Stone Installation.....	23
Site Preparation Formulas.....	25
Paver FAQs.....	26
Paver Calculation Formula.....	27

STRUCTURAL RETAINING WALLS

Keystone Compac® III - Straight.....	28
Keystone Compac® III - Victorian.....	28
Keystone Standard® III - Straight.....	30
Regal Stone Pro® - Straight.....	32
Regal Stone Pro® - Medley.....	32
VERSA-LOK® Square Foot™.....	34
VERSA-LOK® Standard.....	36
VERSA-LOK® Mosaic®.....	38

LANDSCAPE WALLS

Harington® - Medley.....	40
Garden Wall.....	42
Munich™ Wall.....	43
Stonegate®.....	44
VERSA-LOK® Accent® and Cobble®.....	46
VERSA-LOK® Veranda™.....	48

Munich™ Wall Fire Pit Kit.....	50
Wall FAQs.....	51
VERSA-LOK® Standard Estimating Worksheet... ..	52
VERSA-LOK® Material Estimating Worksheet.....	53
VERSA-LOK® Mosaic® Unit Specifications.....	54
Column Construction Ideas.....	55

STONE CAPS, TREADS AND STEPS

Pier Caps.....	57
Natural Stone.....	57
Landscape Steps.....	58



6x12

DIMENSIONS

BULLNOSE	6x12
Width (in.)	6
Length (in.)	12
Height (in.)	2 3/8
Layers/Cube	4
Sq. Ft./Cube	104
Pieces/Cube	208
Weight/Cube (lbs.)	2,375
Bands/Cube	4
Sq. Ft./Band	26
Weight/Band (lbs.)	594
Pieces/Band	52
Pieces/Sq. Ft.	2
Part # (Standard)	LBW6
Part # (Antiqued)	TLBW6

PRODUCT DETAILS

- Compressive Strength: The average compressive strength shall not be less than 8,000 PSI.
- Resistance to Freeze/Thaw Cycle: Dry weight loss not to be greater than 1% of weight when subjected to 50 cycles of freezing and thawing.
- Absorption: The average absorption of test samples shall not be greater than 5%.
- Made according to ASTM C936 specifications.

NOTE: Available in standard finish and antiqued texture.

Standard Colors											
03 Antique Grey	46 Bedford Brown	08 Brown	09 Brown Flash	36 Butternut	47 Hickory Blend	55 North Creek	645 Old Chicago	06 Raven Black	04 Red	05 Red Flash	644 River Sq. Red
●	●*	●*	●*	●	●	●		●		●*	

*Limited availability



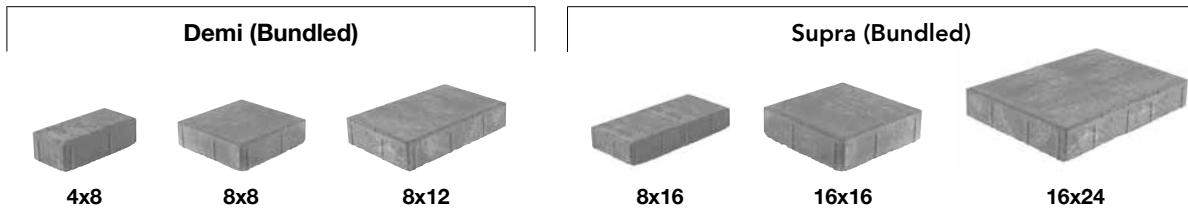

DIMENSIONS

CITYSTONE	Demi (Bundled)			Supra (Bundled)		
	4x8	8x8	8x12	8x16	16x16	16x24
Product	4x8	8x8	8x12	8x16	16x16	16x24
Width (in.)	4	8	8	8	16	16
Length (in.)	8	8	12	16	16	24
Height (in.)	2 3/8	2 3/8	2 3/8	2 3/8	2 3/8	2 3/8
Layers/Cube	10			10		
Sq. Ft./Cube	103			103		
Pieces/Cube	80	80	80	20	20	20
Weight/Cube (lbs.)	2,971			2,971		
Bands/Cube	Combined Cube/No Bands			Combined Cube/No Bands. Not intended for vehicular applications.		
Sq. Ft./Band						
Weight/Band (lbs.)						
Pieces/Band						
Pieces/Sq. Ft.	2.33			0.58		
Part #	36378			36478		

PRODUCT DETAILS

- Made of durable concrete with iron oxide pigments that will resist fading with extended UV exposure. Meets or exceeds applicable requirements of ASTM C936 and C1782.
- Joints and surfaces meet ADA gap and lippage requirements.
- Smooth surfaces and finely chamfered edges combine to create a sleek and contemporary look.

NOTES: Contempra 6x9 (page 7) can be used as a border with CityStone. Contempra is available in Raven Black. Full cubes only. Standard finish only.

Standard Colors											
03 Antique Grey	46 Bedford Brown	08 Brown	09 Brown Flash	36 Butternut	47 Hickory Blend	55 North Creek	645 Old Chicago	06 Raven Black	04 Red	05 Red Flash	644 River Sq. Red
●	●*				●	●					

*Limited availability

INSTALLATION PATTERNS

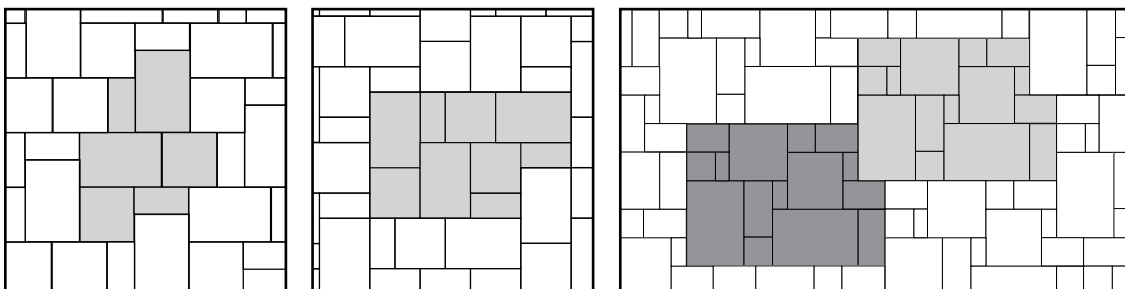

Demi Pattern 01
240 pieces of 4x8, 8x8 and 8x12

Demi Pattern 02
240 pieces of 4x8, 8x8 and 8x12

Demi and Supra Pattern



4x8

DIMENSIONS

CLASSIC BRICK	
Product	4x8
Width (in.)	4
Length (in.)	8
Height (in.)	2 3/8
Layers/Cube	9
Sq. Ft./Cube	96
Pieces/Cube	432
Weight/Cube (lbs.)	2,500
Bands/Cube	6
Sq. Ft./Band	16
Weight/Band (lbs.)	417
Pieces/Band	72
Pieces/Sq. Ft.	4.5
Part #	HC+color

PRODUCT DETAILS

- Compressive Strength: The average compressive strength shall not be less than 8,000 PSI.
- Resistance to Freeze/Thaw Cycle: Dry weight loss not to be greater than 1% of weight when subjected to 50 cycles of freezing and thawing.
- Absorption: The average absorption of test samples shall not be greater than 5%.
- Made according to ASTM C936 specifications.

NOTES: Full cubes only. Available in antiqued texture only.

Standard Colors											
03 Antique Grey	46 Bedford Brown	08 Brown	09 Brown Flash	36 Butternut	47 Hickory Blend	55 North Creek	645 Old Chicago	06 Raven Black	04 Red	05 Red Flash	644 River Sq. Red
	•						•	•			•*

*Limited availability

INSTALLATION PATTERNS

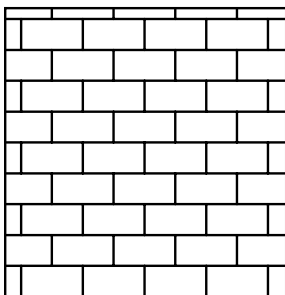

Runner Bond

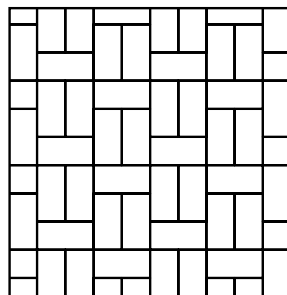

Single Basket weave

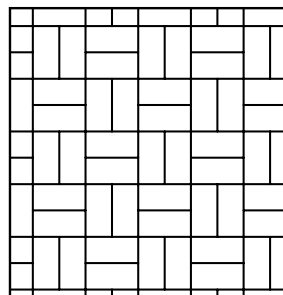

Double Basket weave

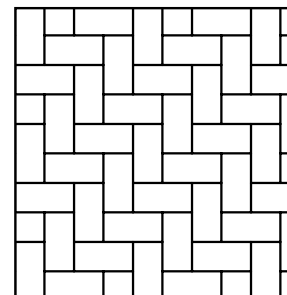

Herringbone



6x9

DIMENSIONS

CONTEMPRA	
Product	6x9
Width (in.)	6
Length (in.)	9
Height (in.)	2 3/8
Layers/Cube	9
Sq. Ft./Cube	93
Pieces/Cube	225
Weight/Cube (lbs.)	2,450
Bands/Cube	5
Sq. Ft./Band	18.6
Weight/Band (lbs.)	490
Pieces/Band	45
Pieces/Sq. Ft.	2.42
Part #	CS6L

PRODUCT DETAILS

- Compressive Strength: The average compressive strength shall not be less than 8,000 PSI.
- Resistance to Freeze/Thaw Cycle: Dry weight loss not to be greater than 1% of weight when subjected to 50 cycles of freezing and thawing.
- Absorption: The average absorption of test samples shall not be greater than 5%.
- Made according to ASTM C936 specifications.

NOTES: Full cubes only. Standard finish only. Contemptra makes an ideal border for the CityStone Series (page 5).

Standard Colors											
03 Antique Grey	46 Bedford Brown	08 Brown	09 Brown Flash	36 Butternut	47 Hickory Blend	55 North Creek	645 Old Chicago	06 Raven Black	04 Red	05 Red Flash	644 River Sq. Red
●	●*		●	●*	●	●		●		●*	

*Limited availability

INSTALLATION PATTERNS

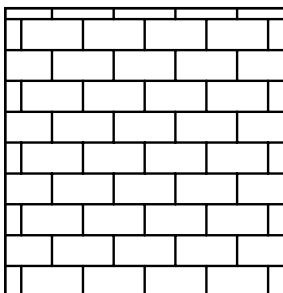

Runner Bond

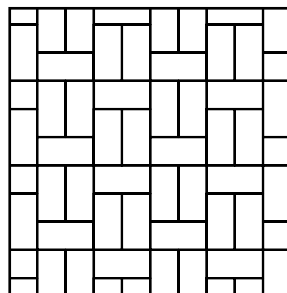

Single Basket weave

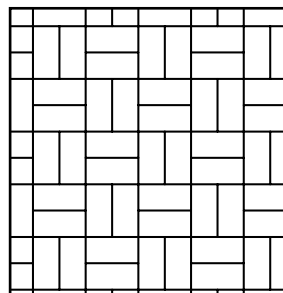

Double Basket weave

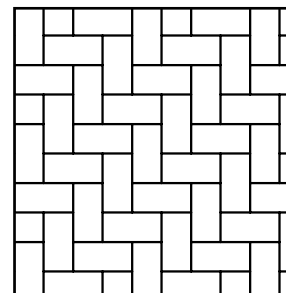

Herringbone



4x8

DIMENSIONS

HOLLAND STONE	4x8
Width (in.)	4
Length (in.)	8
Height (in.)	2 3/8
Layers/Cube	9
Sq. Ft./Cube	96
Pieces/Cube	432
Weight/Cube (lbs.)	2,500
Bands/Cube	6
Sq. Ft./Band	16
Weight/Band (lbs.)	417
Pieces/Band	72
Pieces/Sq. Ft.	4.5
Part #	H6

PRODUCT DETAILS

- Compressive Strength: The average compressive strength shall not be less than 8,000 PSI.
- Resistance to Freeze/Thaw Cycle: Dry weight loss not to be greater than 1% of weight when subjected to 50 cycles of freezing and thawing.
- Absorption: The average absorption of test samples shall not be greater than 5%.
- Made according to ASTM C936 specifications.

NOTES: Available in standard finish only. Antiqued texture available by special order only.

Standard Colors											
03 Antique Grey	46 Bedford Brown	08 Brown	09 Brown Flash	36 Butternut	47 Hickory Blend	55 North Creek	645 Old Chicago	06 Raven Black	04 Red	05 Red Flash	644 River Sq. Red
●			●*	●*	●			●	●	●	

*Limited availability

INSTALLATION PATTERNS

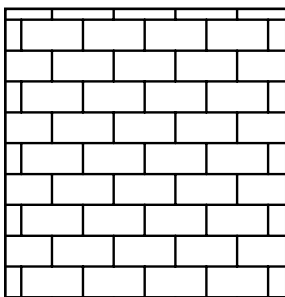

Runner Bond

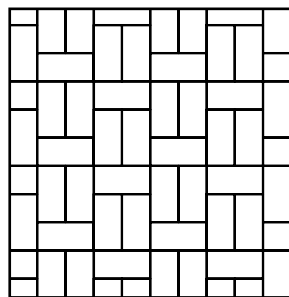

Single Basket weave

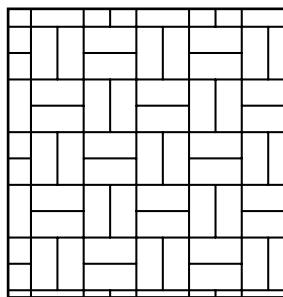

Double Basket weave

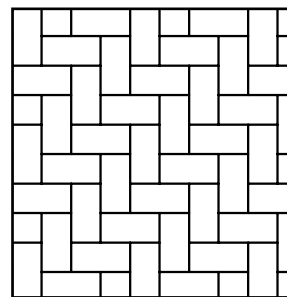

Herringbone

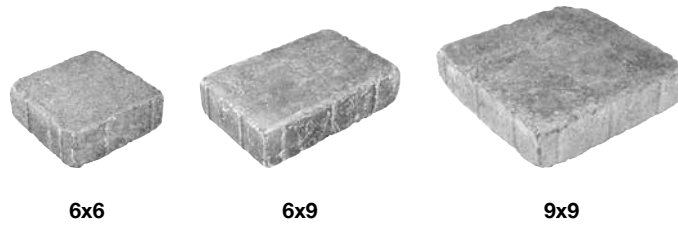

DIMENSIONS

MUNICH SERIES			
Product	6x6	6x9	9x9
Width (in.)	6	6	9
Length (in.)	6	9	9
Height (in.)	2 3/8	2 3/8	2 3/8
Layers/Cube	9	9	9
Sq. Ft./Cube	87	93	111
Pieces/Cube	315	225	180
Weight/Cube (lbs.)	2,400	2,450	2,950
Bands/Cube	7	5	5
Sq. Ft./Band	12.43	18.6	22.2
Weight/Band (lbs.)	337	490	580
Pieces/Band	45	45	36
Pieces/Sq. Ft.	3.62	2.42	1.62
Part #	SF6Q	SF6L	SF6X

PRODUCT DETAILS

- Compressive Strength: The average compressive strength shall not be less than 8,000 PSI.
- Resistance to Freeze/Thaw Cycle: Dry weight loss not to be greater than 1% of weight when subjected to 50 cycles of freezing and thawing.
- Absorption: The average absorption of test samples shall not be greater than 5%.
- Made according to ASTM C936 specifications.

NOTE: Available in antiqued texture only.

Standard Colors											
03	46	08	09	36	47	55	645	06	04	05	644
Antique Grey	Bedford Brown	Brown	Brown Flash	Butternut	Hickory Blend	North Creek	Old Chicago	Raven Black	Red	Red Flash	River Sq. Red

INSTALLATION PATTERNS

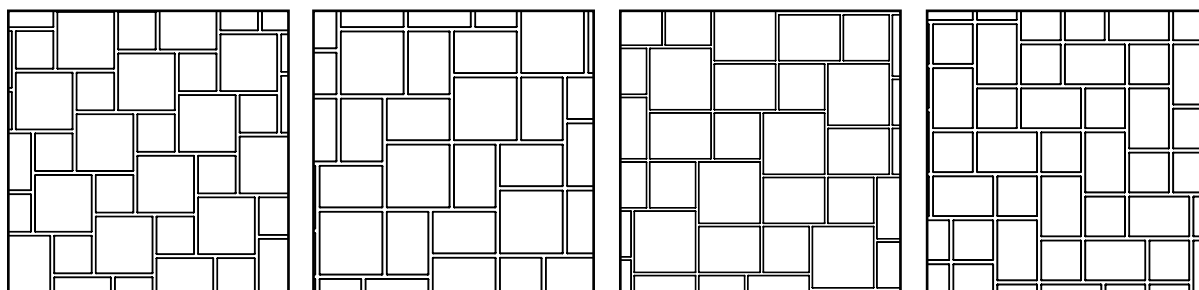

1:1 Herringbone
6x6 (31%), 9x9 (69%)

2:1 Herringbone
(2) 6x9 (57%), 9x9 (43%)

1:1 Herringbone
6x6 (21%), 6x9 (32%),
9x9 (47%)

1:1 Herringbone
6x6 (40%), 6x9 (60%)

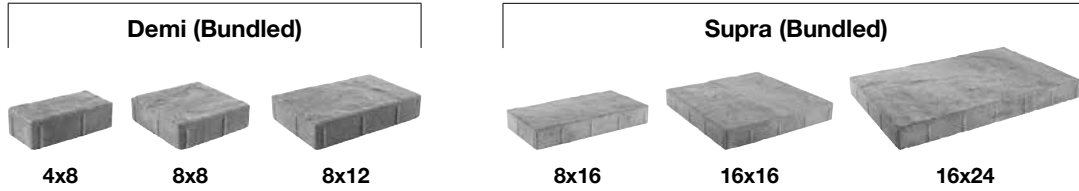

DIMENSIONS

PANORAMA	Demi (Bundled)			Supra (Bundled)		
Product	4x8	8x8	8x12	8x16	16x16	16x24
Width (in.)	4	8	8	8	16	16
Length (in.)	8	8	12	16	16	24
Height (in.)	2 ¾	2 ¾	2 ¾	2 ¾	2 ¾	2 ¾
Layers/Cube	10			10		
Sq. Ft./Cube	103			103		
Pieces/Cube	80	80	80	20	20	20
Weight/Cube (lbs.)	2,881			2,881		
Bands/Cube	Combined cube. No bands.			Combined cube. No bands. Not intended for vehicular applications.		
Sq. Ft./Band						
Weight/Band (lbs.)						
Pieces/Band						
Pieces/Sq. Ft.	2.33			0.58		
Part #	36778			36878		

PRODUCT DETAILS

- Compressive Strength: The average compressive strength shall not be less than 8,000 PSI.
- Resistance to Freeze/Thaw Cycle: Dry weight loss not to be greater than 1% of weight when subjected to 50 cycles of freezing and thawing.
- Absorption: The average absorption of test samples shall not be greater than 5%.
- Made according to ASTM C936 specifications.

NOTE: Available in standard finish only.

Standard Colors											
03 Antique Grey	46 Bedford Brown	08 Brown	09 Brown Flash	36 Butternut	47 Hickory Blend	55 North Creek	645 Old Chicago	06 Raven Black	04 Red	05 Red Flash	644 River Sq. Red
•	•				•	•					

INSTALLATION PATTERNS

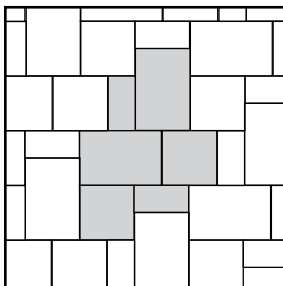

Demi Pattern 01
240 pieces of 4x8, 8x8 and 8x12

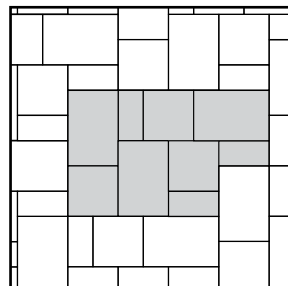

Demi Pattern 02
240 pieces of 4x8, 8x8 and 8x12

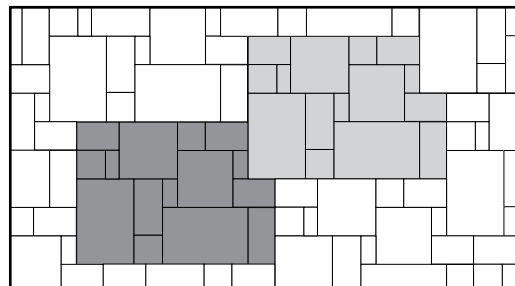

Demi and Supra Pattern

DIMENSIONS

PANORAMA CIRCLE	
Diameter (in.)	10 - 1 ¼
Coverage	81 sq. ft.
Kits Required	1 per circle
Kits/Pattern	1
Pieces/Cube	170
Pallet Weight (lbs.)	2,868
Part #	SSC6

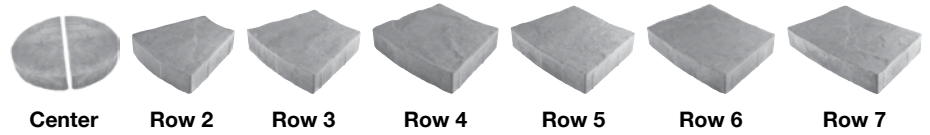

NOTE: Available in standard finish only.

Standard Colors											Special Order	
03 Antique Grey	46 Bedford Brown	08 Brown	09 Brown Flash	36 Butternut	47 Hickory Blend	55 North Creek	645 Old Chicago	06 Raven Black	04 Red	05 Red Flash	644 River Sq. Red	76 Ocean City Sand
•				•	•	•						•

INSTALLATION PATTERNS

The diagram shows the layout of the Circle Kit Cube. If you go by this diagram you will see that each layer of the cube has these same pieces in this order. You will have left over pieces. Another way to know which pieces go on each row is to pre-stack them by size before you begin laying the circle. This will help eliminate the need for cutting. Extra pieces could be used for stepping stones or cuts within the circle if needed.

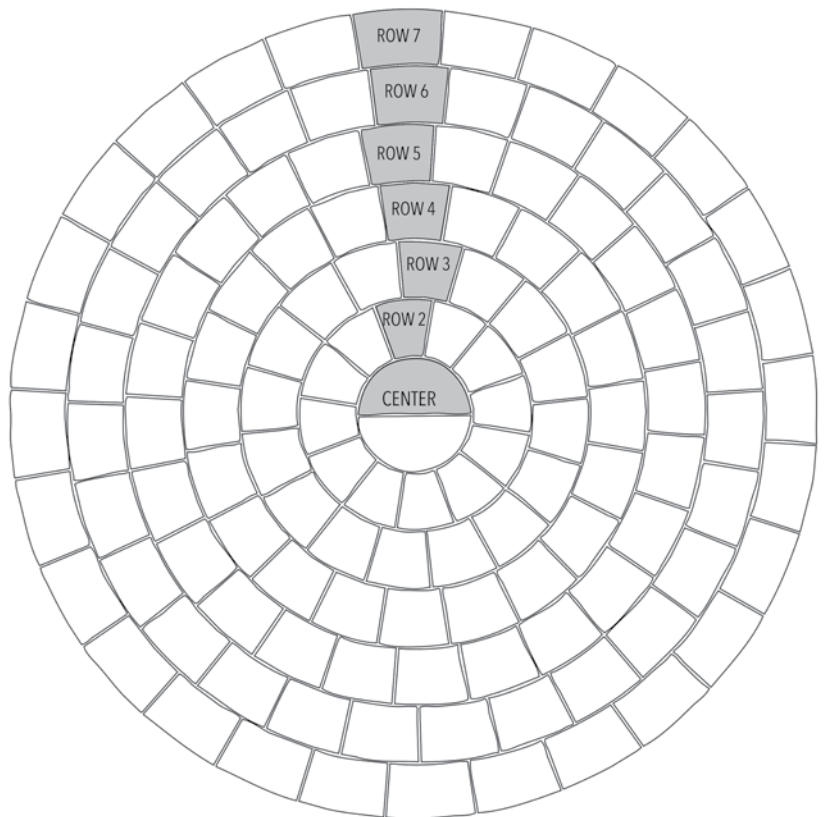
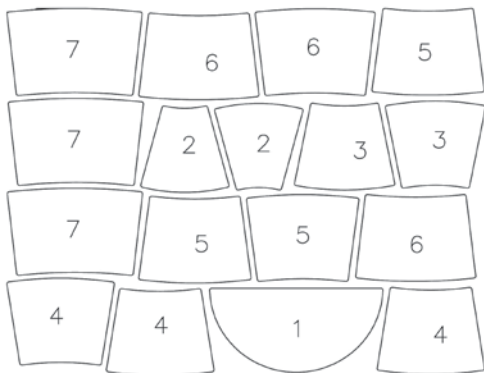

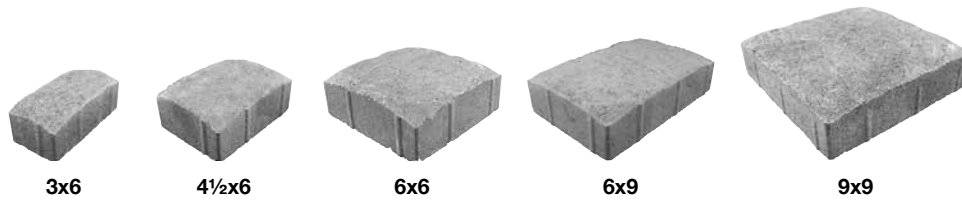

DIMENSIONS

ROMAN COBBLE					
Product	3x6	4 1/2x6	6x6	6x9	9x9
Width (in.)	3	4 1/2	6	6	9
Length (in.)	6	6	6	9	9
Height (in.)	2 3/8	2 3/8	2 3/8	2 3/8	2 3/8
Layers/Cube	8	8	9	9	9
Sq. Ft./Cube	78	81	87	93	111
Pieces/Cube	560	392	315	225	180
Weight/Cube (lbs.)	2,020	2,190	2,360	2,450	2,950
Bands/Cube	7	7	7	5	5
Sq. Ft./Band	11.08	11.67	12.43	18.6	22.2
Weight/Band (lbs.)	288	313	337	490	580
Pieces/Band	80	56	45	45	36
Pieces/Sq. Ft.	7.24	4.84	3.62	2.42	1.62
Part # (Standard)	RC6M	RC6S	RC6Q	RC6L	RC6X
Part # (Antiqued)	T6M	T6S	T6Q	T6L	T6X

PRODUCT DETAILS

- Compressive Strength: The average compressive strength shall not be less than 8,000 PSI.
- Resistance to Freeze/Thaw Cycle: Dry weight loss not to be greater than 1% of weight when subjected to 50 cycles of freezing and thawing.
- Absorption: The average absorption of test samples shall not be greater than 5%.
- Made according to ASTM C936 specifications.

NOTE: Available in standard finish and antiqued texture.

Standard Colors											
03 Antique Grey	46 Bedford Brown	08 Brown	09 Brown Flash	36 Butternut	47 Hickory Blend	55 North Creek	645 Old Chicago	06 Raven Black	04 Red	05 Red Flash	644 River Sq. Red
●	●*	●* Special Order	●*	●	●			● 6x9 Only		●*	

*Limited availability

INSTALLATION PATTERNS

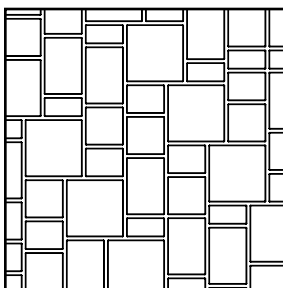

5-Size Herringbone
3x6 (8%), 4.5x6 (12%),
6x6 (17%), 6x9 (25%),
9x9 (38%)

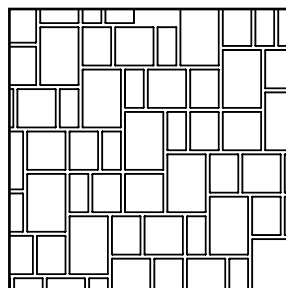

4-Size Herringbone
3x6 (13%), 4.5x6 (20%),
6x6 (27%), 6x9 (40%)

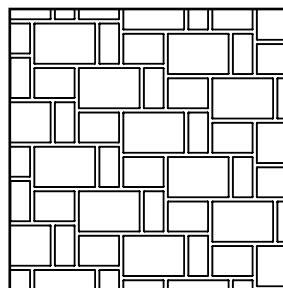

1:1 Herringbone
3x6 (18%), 4.5x6 (27%),
6x9 (55%)

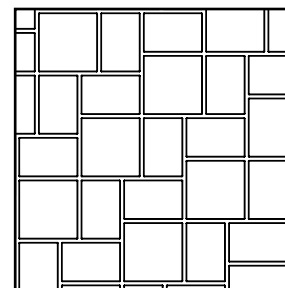

2:1 Herringbone
6x9 (57%), 9x9 (43%)

DIMENSIONS

COBBLE CIRCLE					
Product	A	B	C	D	E
Width (in.)	2 11/16	6	4 9/16	2 11/16	4
Length (in.)	5 1/2	5 1/2	5 1/2	5 1/2	5 1/2
Height (in.)	2 3/8	2 3/8	2 3/8	2 3/8	2 3/8
Stones/Sq. Ft.	6.7				
Stones/Cube	10	20	280	10	220
Stone Weight (lbs.)	2.3	6.5	4.8	2.8	4.3
Cube Weight (lbs.)	2,352				
Sq. Ft./Cube	84				
Part #	63778+color				

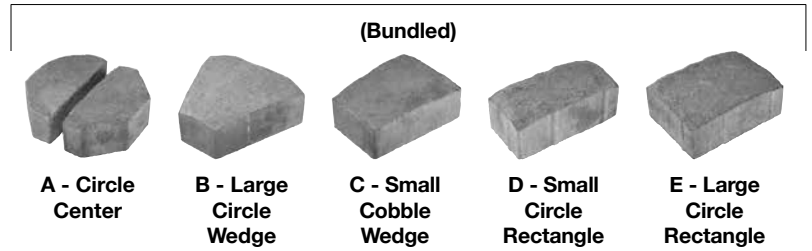

NOTES: Available in standard finish only. Actual square footage of the completed circle = 71 sq.ft. There will be extra pieces left over from the full pallet after circle design is created.

Standard Colors											
03 Antique Grey	46 Bedford Brown	08 Brown	09 Brown Flash	36 Butternut	47 Hickory Blend	55 North Creek	645 Old Chicago	06 Raven Black	04 Red	05 Red Flash	644 River Sq. Red

PRODUCT DETAILS

- Compressive Strength: The average compressive strength shall not be less than 8,000 PSI.
- Resistance to Freeze/Thaw Cycle: Dry weight loss not to be greater than 1% of weight when subjected to 50 cycles of freezing and thawing.
- Absorption: The average absorption of test samples shall not be greater than 5%.
- Made according to ASTM C936 specifications.

INSTALLATION PATTERNS

114" Diameter
(9'-6")

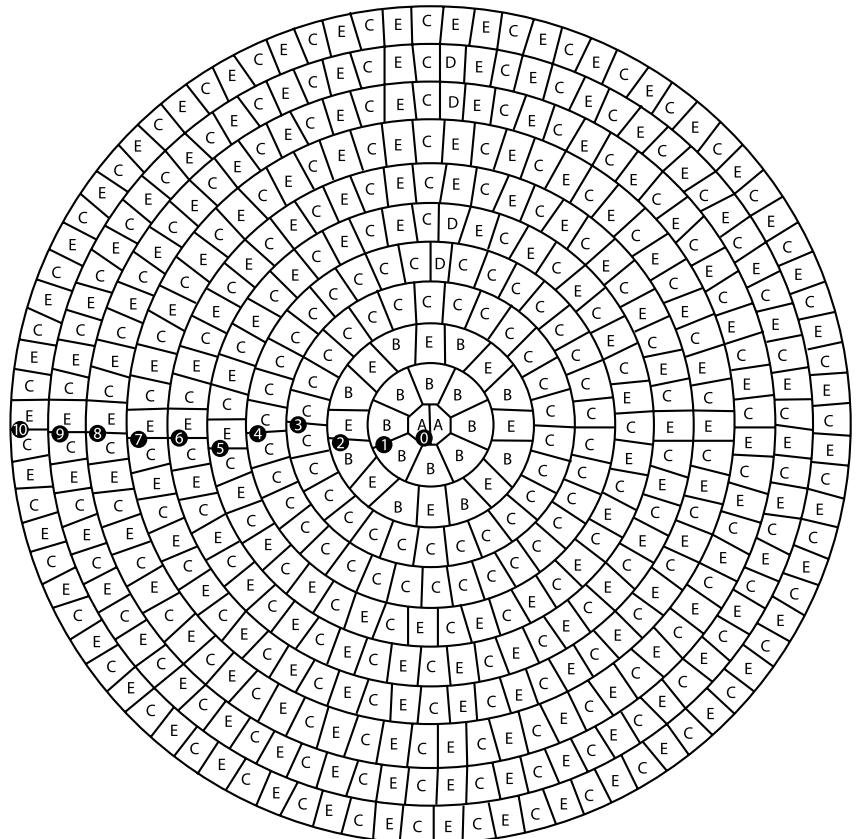
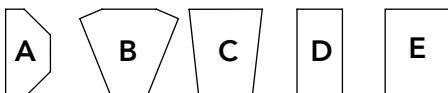

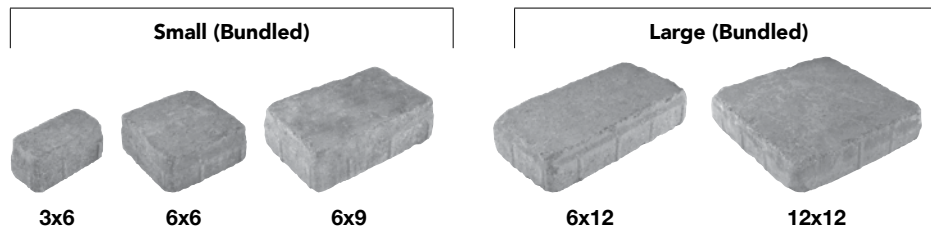

DIMENSIONS

VIENNA CLASSIC	Small (Bundled)			Large (Bundled)	
Product	3x6	6x6	6x9	6x12	12x12
Width (in.)	3	6	6	6	12
Length (in.)	6	6	9	12	12
Height (in.)	2 ¾	2 ¾	2 ¾	2 ¾	2 ¾
Layers/Cube	10			10	
Sq. Ft./Cube	113			114	
Pieces/Cube	150	160	160	120	60
Weight/Cube (lbs.)	3,300			3,450	
Part #	VC7S_T			VC7L_T	

NOTE: Available in antiqued texture only.

PRODUCT DETAILS

- Compressive Strength: The average compressive strength shall not be less than 8,000 PSI.
- Resistance to Freeze/Thaw Cycle: Dry weight loss not to be greater than 1% of weight when subjected to 50 cycles of freezing and thawing.
- Absorption: The average absorption of test samples shall not be greater than 5%.
- Made according to ASTM C936 specifications.

Standard Colors											
03 Antique Grey	46 Bedford Brown	08 Brown	09 Brown Flash	36 Butternut	47 Hickory Blend	55 North Creek	645 Old Chicago	06 Raven Black	04 Red	05 Red Flash	644 River Sq. Red

INSTALLATION PATTERNS

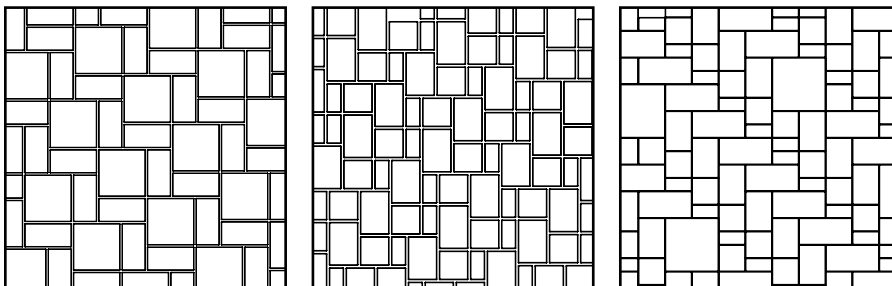

2-Size Herringbone
6x12 and 12x12

3-Size Herringbone
3x6, 6x6 and 6x9

5-Size Random*

*The Five-Size Random pattern is determined by the length of the horizontal and vertical seams. The shorter the straight lines, the more random the pattern. The most random of patterns won't have seams exceeding the length of all five pieces, either horizontally or vertically. A random pattern is the best option when using just the Vienna Classic small cube since the piece count won't work for a 1:1:1 pattern. You will have some pieces left over. It is a random pattern, so you should be able to add them in, or use them for cuts.

In order to make this pattern using only the Vienna Classic small cube, you will have to modify (for each cube used) three of the 6x6 pieces by cutting them in half (making two 3x6) and using 3 of the 6x9 pieces in place of the 3x6, 6x6 combo rows. By doing this, you will make the cube capable of a 1:1:1 Random Herringbone design.

Cut 3 pieces in half to make two 3x6's for each cube used.

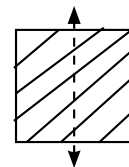

Use 3 pieces of 6x9 in place of where a 3x6 & 6x6 would normally go in this pattern in each cube used.

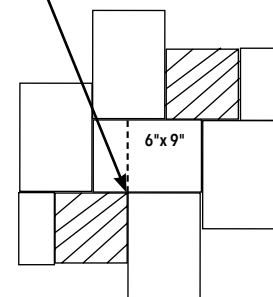

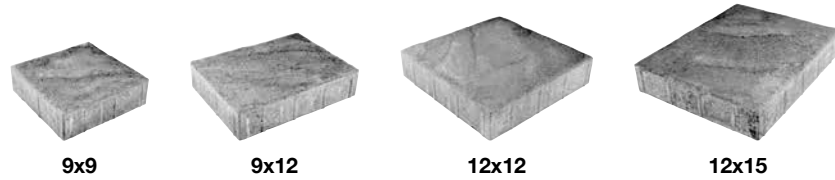

DIMENSIONS

VILLA GRANDE				
Product	9x9	9x12	12x12	12x15
Width (in.)	9	9	12	12
Length (in.)	9	12	12	15
Height (in.)	2 ¾	2 ¾	2 ¾	2 ¾
Layers/Cube	8	8	8	8
Sq. Ft./Cube	90	96	96	90
Pieces/Cube	160	128	96	72
Weight/Cube (lbs.)	2,720	2,850	2,820	2,690
Bands/Cube	5	4	4	3
Sq. Ft./Band	18	24	23	30
Weight/Band (lbs.)	544	712	712	897
Pieces/Band	32	32	24	24
Pieces/Sq. Ft.	1.8	1.33	1	0.8
Part # (Standard)	VG7S	VG7L	VG7J	VG7G
Part # (Antiqued)	VG7S_T	VG7L_T	VG7J_T	VG7G_T

PRODUCT DETAILS

- Compressive Strength: The average compressive strength shall not be less than 8,000 PSI.
- Resistance to Freeze/Thaw Cycle: Dry weight loss not to be greater than 1% of weight when subjected to 50 cycles of freezing and thawing.
- Absorption: The average absorption of test samples shall not be greater than 5%.
- Made according to ASTM C936 specifications.

NOTE: Available in standard and antiqued texture. *The 12x15 unit is not intended for vehicular applications.

Standard Colors*											
03 Antique Grey	46 Bedford Brown	08 Brown	09 Brown Flash	36 Butternut	47 Hickory Blend	55 North Creek	645 Old Chicago	06 Raven Black	04 Red	05 Red Flash	644 River Sq. Red
•	• Special Order			•	•						

INSTALLATION PATTERNS

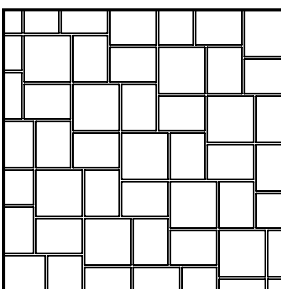

2:1 Herringbone
9x12 (60%), 12x12 (40%)

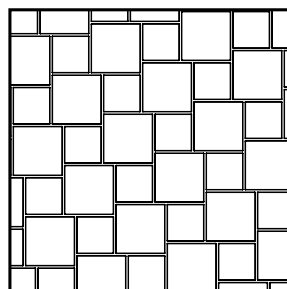

1:1 Herringbone
9x9 (36%), 12x12 (64%)

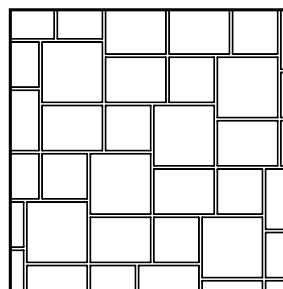

3-Size Herringbone
9x9 (25%), 9x12 (33%),
12x12 (42%)

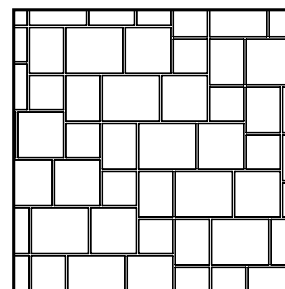

4-Size Herringbone
9x9 (16%), 9x12 (21%),
12x15 (35%)

WARNING:

Because of the high-profile (ridged-top) of the Villa Grande Series, protection is needed when using a plate compactor in order to avoid scratching the surface. The recommended application is the use of a layer between the compactor and the pavers. The preferred anti-suffing device is a neoprene pad for the compactor. Other options include a mat, cardboard, thin plywood, carpeting or soil separation fabric. Keystone Hardscapes suggests using one of these separators with all of our paving lines.

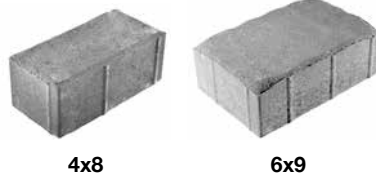

DIMENSIONS

HOLLAND STONE & ROMAN COBBLE

Product	Holland Stone 4x8	Roman Cobble 6x9
Width (in.)	4	6
Length (in.)	8	9
Height (in.)	3 1/8	3 1/8
Layers/Cube	7	7
Sq. Ft./Cube	75	73
Pieces/Cube	336	175
Weight/Cube (lbs.)	2,850	2,450
Bands/Cube	6	5
Sq. Ft./Band	12.5	14.6
Weight/Band (lbs.)	475	490
Pieces/Band	56	35
Pieces/Sq. Ft.	4.5	2.42
Part #	H8	RC8

PRODUCT DETAILS

- Compressive Strength: The average compressive strength shall not be less than 8,000 PSI.
- Resistance to Freeze/Thaw Cycle: Dry weight loss not to be greater than 1% of weight when subjected to 50 cycles of freezing and thawing.
- Absorption: The average absorption of test samples shall not be greater than 5%.
- Made according to ASTM C936 specifications.

NOTES: Special order only. Limited availability.



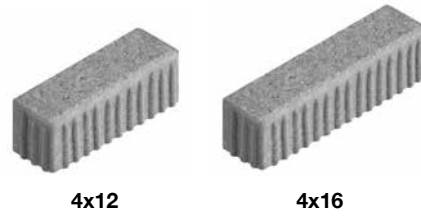

DIMENSIONS

CITYLOCK		
Product	4x12	4x16
Width (in.)	4	4
Length (in.)	12	16
Height (in.)	4	4
Centimeter (Thickness)	10	10
Part #	32302	n/a

NOTES: Special order only. Available in standard finish only.

PRODUCT DETAILS

- Made of durable concrete with iron oxide pigments that will resist fading with extended UV exposure. Meets or exceeds applicable requirements of ASTM C936.
- Crenelated sidewalls interlock for herringbone-equivalent creep resistance to enable innovative installation patterns in vehicular applications.
- Linear shape easily forms stacked, runner, and a variety of herringbone patterns.
- Smooth surfaces and finely chamfered edges combine to create a sleek and contemporary look.

INSTALLATION PATTERNS

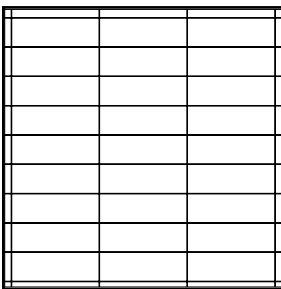

Stack

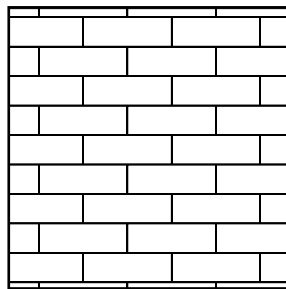

Half Offset Runner

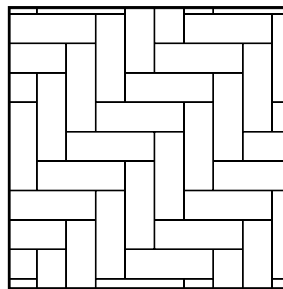

Herringbone





5x10

DIMENSIONS

ECO-CITYLOCK	
Product	5x10
Width (in.)	5
Length (in.)	10
Height (in.)	3 1/8
Millimeter (Thickness)	80
Part #	32400

NOTES: Special order only. Available in standard finish only.

PRODUCT DETAILS

- Initial infiltration rate exceeds 700 in./hour ASTM C1781.
- Made of durable concrete with iron oxide pigments that will resist fading with extended UV exposure. Meets or exceeds applicable requirements of ASTM C936.
- Versatile 2:1 shape easily forms stacked, runner, basket weave, and herringbone patterns.
- Smooth surfaces and microchamfered edges combine to create a sleek and contemporary look.
- Perfect for heavy vehicular applications.

INSTALLATION PATTERNS

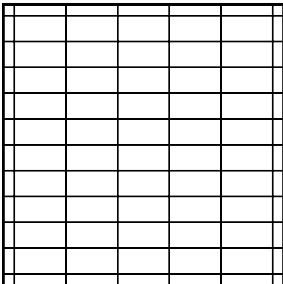

Stack

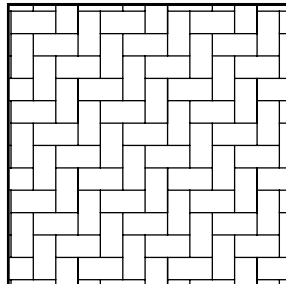

Herringbone



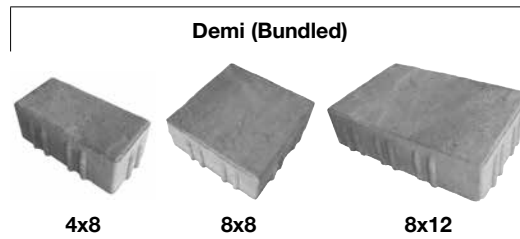

DIMENSIONS

ECO-PANORAMA	Demi (Bundled)		
Product	4x8	8x8	8x12
Width (in.)	4	8	8
Length (in.)	8	8	12
Height (in.)	3 1/8	3 1/8	3 1/8
Millimeter (Thickness)	80	80	80
Part #	n/a		

NOTES: Special order only. Available in standard finish only.

INSTALLATION PATTERNS

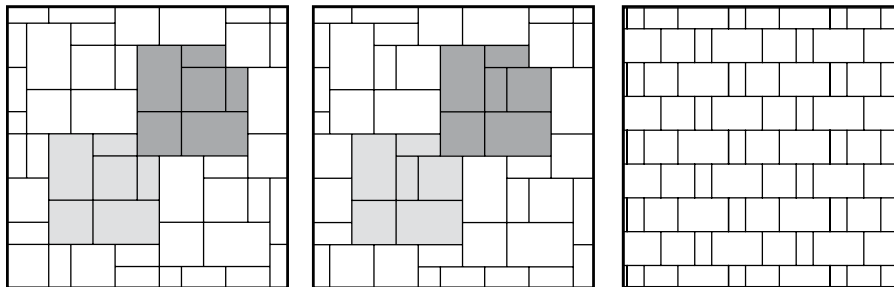

Ashlar 01

Ashlar 02

Random Runner

PRODUCT DETAILS

- Infiltration rate >758 in./hour per ASTM C1781.
- Perfect for light vehicular applications.
- Made of durable concrete with iron oxide pigments that will resist fading with extended UV exposure. Meets or exceeds applicable requirements of ASTM C936.
- Designed to be installed in an efficient repeating runner or ashlar pattern, with equal numbers of 1:2, square, and 3:2 stones.
- Riven stone surfaces and softened edges create the natural look of weathered flagstone.



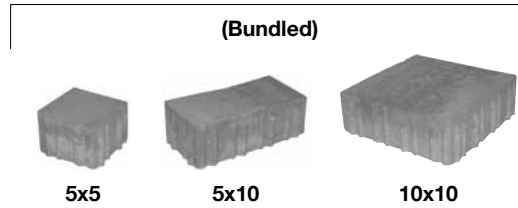

DIMENSIONS

ECO-VENETIAN	(Bundled)		
Product	5x5	5x10	10x10
Width (in.)	5	5	10
Length (in.)	5	10	10
Height (in.)	3 1/8	3 1/8	3 1/8
Millimeter (Thickness)	80	80	80
Sq. ft./Cube	84		
Pieces/Cube	80	136	32
Weight/Cube (lbs.)	3,178		
Pieces/Sq. Ft.	5.8	2.9	1.44
Part #	68921		

NOTES: Special order only. Available in standard finish only.

PRODUCT DETAILS

- Open area = 5.8%. Infiltration rate of 696 in./hour per ASTM C1781.
- Perfect for heavy vehicular applications.
- Made of durable concrete with iron oxide pigments that will resist fading with extended UV exposure. Meets or exceeds applicable requirements of ASTM C936.
- Creates dramatic and dynamic interaction with sunlight through its cleft and chamferless surfaces.

Standard Colors											
03 Antique Grey	46 Bedford Brown	08 Brown	09 Brown Flash	36 Butternut	47 Hickory Blend	55 North Creek	645 Old Chicago	06 Raven Black	04 Red	05 Red Flash	644 River Sq. Red

INSTALLATION PATTERNS

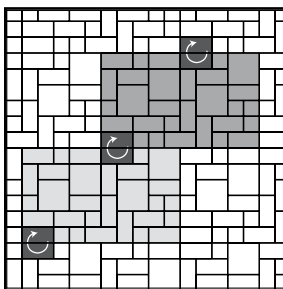

Mech Lay Step 1

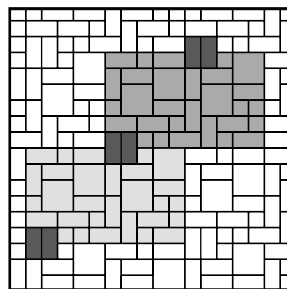

Mech Lay Step 2

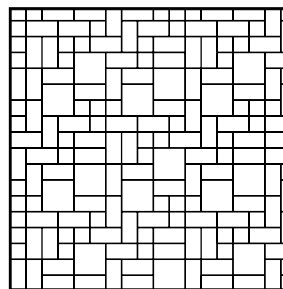

Finished Installation

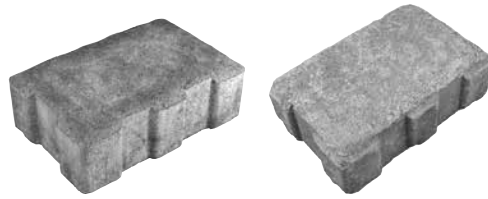

6x9
Standard Finish

6x9
Antiqued Texture

DIMENSIONS

ROMAN COBBLE GREEN	6x9
Width (in.)	6
Length (in.)	9
Height (in.)	3 1/8
Layers/Cube	7
Sq. Ft./Cube	86
Pieces/Cube	210
Weight/Cube (lbs.)	2,840
Bands/Cube	5
Sq. Ft./Band	17.2
Weight/Band (lbs.)	568
Pieces/Band	42
Pieces/Sq. Ft.	2.42
Part # (Standard)	GR8L
Part # (Antiqued)	GR8L_T

PRODUCT DETAILS

- Infiltration rate >800 in./hour per ASTM C1781.
- Permeable pavers are the latest environmentally-friendly hardscape paver product from Keystone Hardscapes.
- Permeable pavers with storage bed systems may be used to meet the groundwater recharge requirements of the NJDEP.
- LEED point eligibility for sustainable sites.
- Meets U.S. EPA stormwater performance criteria as a best management practice (BMP).
- Roman Cobble Green 6x9 permeable paver is the same overall dimension as our standard 6x9 paver allowing the designer to transition from traditional paver to permeable pavers seamlessly within the same application.

INSTALLATION PATTERNS

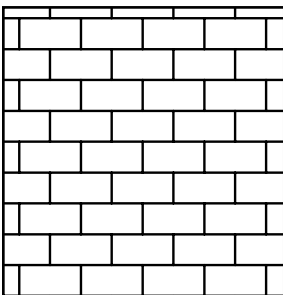

Running Bond

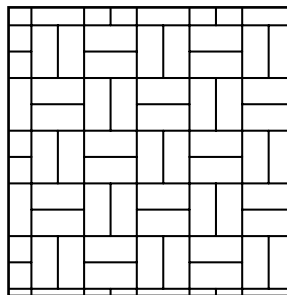

Double Basket weave

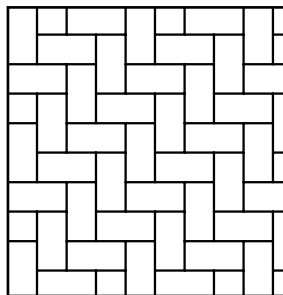

Herringbone

Standard Colors*		
03 Antique Grey	46 Bedford Brown	47 Hickory Blend
●	●	●

*All colors are special order only.

PERMEABLE INTERLOCKING CONCRETE PAVER DETAIL (PICP)

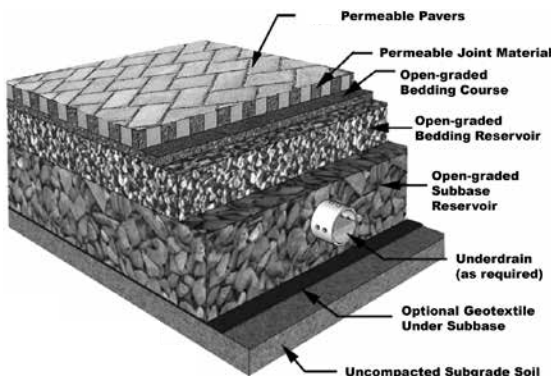

An open-graded base is most commonly used because it has water storage capacity (void space between the aggregates) of typically 30% - 40%. The stone sizes in open-graded bases can be as large as 3 in. (75mm) and as small as 1/4 in. (6mm). There is typically a thinner layer of small stone sizes (6 - 1mm) used for bedding directly under the concrete pavers. The bedding and base bedding material maximizes storage, filtering, and treatment of pollutants in stormwater runoff entering the pavement surface. Open-graded bases are preferred because of the storage and treatment benefits.

If soil infiltration is slow (generally under 0.5 in./hour or 1.3 x 10⁻² m./sec.), perforated plastic pipe drains at the bottom of the base can remove excess water while still allowing some of the water to infiltrate into the soil. The drainage rate for the water contained in the base is typically no greater than 24 hours. Over practically impervious soils or high bedrock, an impervious pond liner can be used to detain, filter and release the water through drain pipes. Regardless of the rate of soil infiltration, the filtering action of the open-graded base can reduce water pollutants.



15 3/4 x 23 7/8

DIMENSIONS

TURFSTONE	15 3/4 x 23 7/8
Width (in.)	15 3/4
Length (in.)	23 7/8
Height (in.)	4
Layers/Cube	6
Sq. Ft./Cube	63
Pieces/Cube	24
Weight/Cube (lbs.)	1,680
Pieces/Sq. Ft.	0.4
Part #	G1001

NOTES: Available in standard finish only. Available in Natural color only.

TURFSTONE GRID PAVER

Turfstone offers specific advantages for erosion control, fire lanes, overflow parking, permeable pavements, slope surface stabilization, tree protection, scenic parks, university campuses, golf courses, emergency access areas and other vehicular access areas. Turfstone pavers have 40% open space and it takes 1/3 cubic foot of material to fill the voids (dependent on compaction.)

MAINTENANCE

Turfstone pavers planted with grass require the same maintenance as lawns, such as watering, mowing, removal of weeds and occasional fertilizing. Placing #8 aggregate may be used inside the Turfstone openings as an alternative. Snow can be plowed from Turfstone if the plow blade is raised slightly above the surface. Because of their large slab-style shape, Turfstone pavers may crack during compaction or while in use. One or two cracks in a unit will not affect the structural integrity or its performance.

Permeable Interlocking Concrete Pavement (PICP) comprises a layer of solid concrete pavers separated by joints filled with small stones. Water enters the joints between the pavers and into an "open-graded" base-crushed stone layer with no small or fine particles. The void spaces among the crushed stone store water and infiltrate it back into the soil sub-grade. The stones in the joints provide permeability, and the base filters storm water and helps reduce pollutants.

PRODUCT DETAILS

- Compressive Strength: The average compressive strength shall not be less than 5,000 PSI.
- Physical Requirements: ASTM 1319-01

Figure A • Typical Detail:

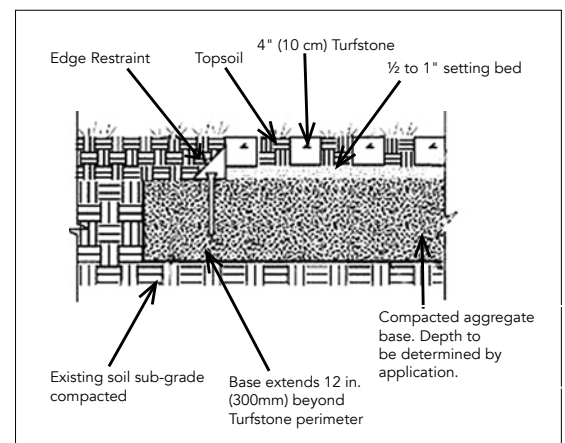
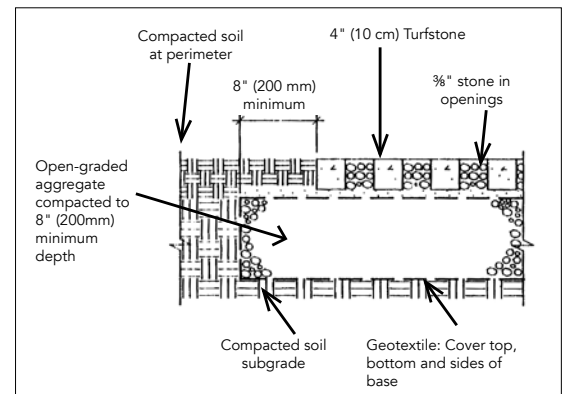

Figure B • Storm Water Run-Off Control:



OVERVIEW FOR PAVING STONE INSTALLATIONS

All paver sizes are nominal and should be pre-measured when doing a job where exact dimensions are critical.

INTERLOCKING CONCRETE PAVER INSTALLATION

Professionals and do-it-yourselfers alike can install interlocking concrete pavers successfully. You will probably have to rent some tools that the average homeowner does not have. If you take your time and pay close attention to the base preparation, you will be pleased with the results.



EXCAVATION:

Before digging, always call the local utility company to locate any underground lines. In general terms, a minimum of 4" of compacted aggregate base is recommended for patios and walkways, and 8" for residential driveways where freeze/thaw conditions exist. Add 3" for the depth of the bedding sand and the paver thickness to determine the total depth to excavate. Excavation should be 6" wider than the finished pavement's dimensions on sides where edge restraint is to be used. Slope and grade are important to ensure proper runoff. It is best to plan at least a ¼" per foot drop, but try not to exceed ½" per foot.



BASE PREPARATION:

As with any building project, the finished pavers will be only as good as the construction of the base. For this reason, this is the MOST important part of the installation process.

First, run a plate compactor over the excavated area, making sure that the soil does not get stuck to the bottom of the plate tamper. Each pass should overlap the previous one by about 4". Compaction should be performed in one direction (north-south) then a second time at a right angle (east-west) to the first compaction. It is suggested that a soil separation fabric be laid down over the compacted sub grade, especially in moist or wet areas, to separate virgin soil from the base.



Now spread the stone base material out evenly in a 2" layer. If material is dry and dusty, use a garden hose to evenly moisten it down. This will help make the gravel easier to rake and faster to compact.

Starting around the outer perimeter, use the plate compactor to pack together the base, again overlapping each pass about 4" and working towards the center. You should make at least two complete passes for each layer. Repeat this process for each subsequent layer of base material until the final thickness is achieved. After final compaction, check the entire area for proper pitch and level conditions. The base should now reflect the final grade of your pavers. If you were to place a straight edge on the surface, there should be no more than a ¼" gap at any point along the straight edge.



EDGE RESTRAINTS:

The borders for the layout design may now be put into place. The edging is laid directly upon the quarry process base and secured with 10" steel spikes. One spike should be used every 2 feet for walkways and patios and every 1 foot for driveways and radii.

SAND SETTING BED:

A setting bed of concrete sand can now be spread on top of the compacted base. Note: It is important to keep the sand dry. Always keep the sand covered in case of rain. It is suggested that you only screed sand for areas where you will be laying pavers that same day. Lay the screed guides (1" outside diameter electrical conduit, strips of wood or other suitable rigid material) on top of the compacted base material 4'- 6' apart and parallel. For narrow areas such as walkways, the PVC edging can be used as a guide with a notched 2" x 4" board. When the pavers are set on the sand and compacted, the 1" of sand will compress to ½" to ⅝" thickness.



INSTALLATION OF PAVERS:

All projects must start at a perfect 90-degree angle. Use the 3-4-5-triangle method to establish this. For an even mix of pavers, select pavers from multiple cubes for optimum color blending. Starting from a permanent edge such as a house, driveway, or even a piece of rigid PVC edge restraint, lay the first paver starting from either side. String lines will assist in assuring straight lines. Spacing between pavers should not exceed ⅛". Set pavers lightly on the sand, never press or hammer them in. If you are doing the project over a couple of days, cover the entire area with plastic overnight if rain is expected.



COMPACTING AND SWEEPING:

Spread and sweep sand over the entire top of the pavers using a stiff bristle broom. Vibrating with a plate compactor will force the sand between the joints stabilizing and leveling the final surface. The recommended application is the use of a layer between the compactor and the pavers. Excess sand should be swept in the joints. Re-sweep additionally as necessary.

OVERVIEW FOR PAVING STONE INSTALLATIONS

These illustrations are just a basic guideline.

These illustrations show only a "cut-away" view. The gravel base should extend beyond the edge restraint an equal amount to the depth.

Typical Residential Detail

Walkway • Patio • Pool Deck

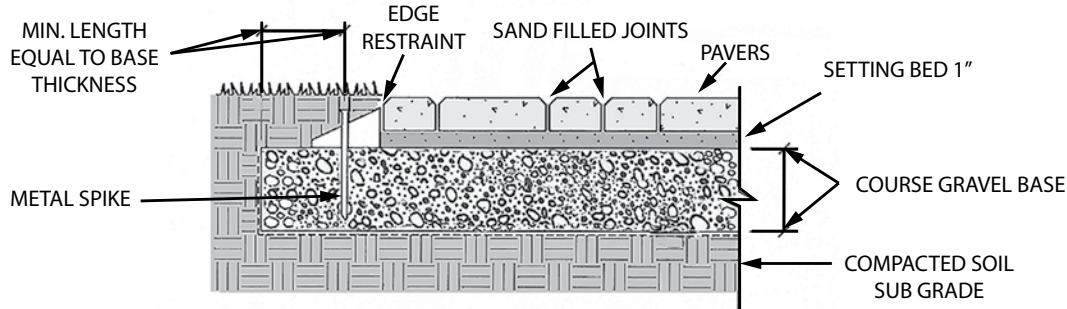

Typical Light Vehicular Detail

Residential Driveway • Light Truck • Shopping Mall • Plaza

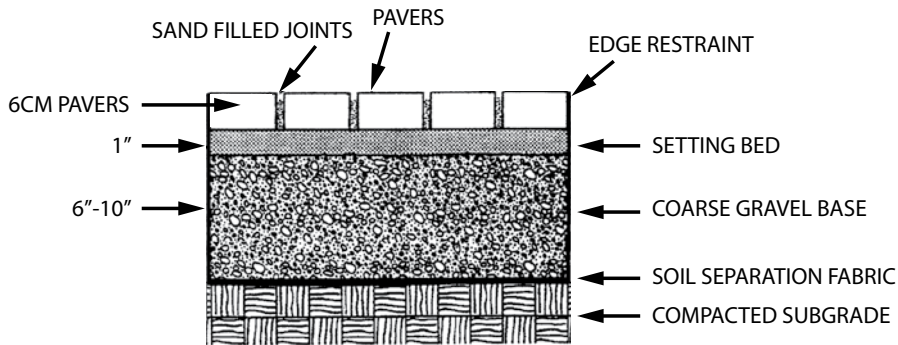

Depending on soil conditions, soil separation fabric may be necessary.

Typical Heavy Construction Detail

Roadway • Industrial/Heavy Truck • Gas Station

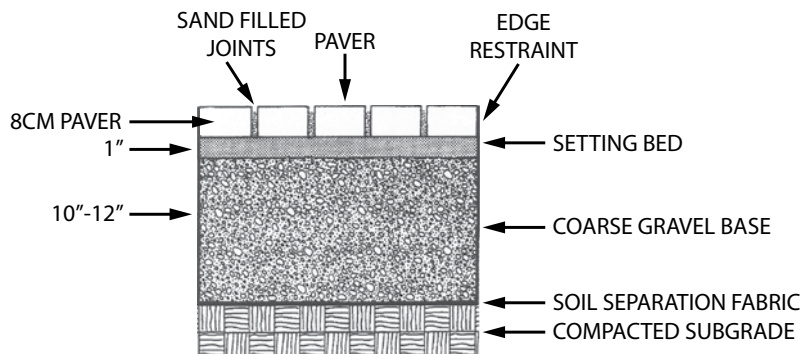

SITE PREPARATION FORMULAS

BASE MATERIAL CALCULATIONS:

The following formula is used to calculate the amount of base material ($\frac{3}{4}$ O.P.).

- Step 1:** Length x width = area (measured in square feet)
- Step 2:** Area \div 12 x inches of base required = total cubic feet of base
- Step 3:** Cubic feet of base x 1.25 (compaction factor) \div 27 = yards of base needed

BEDDING SAND CALCULATIONS:

The following formula is used to calculate the amount of bedding sand (clean, sharp, well graded).

Note: 1" to 1 1/2", but no greater than 1 1/2".

- Step 1:** Length x width = area (measured in square feet)
- Step 2:** Area \div 12 x 1" (typical thickness) = cubic feet of sand
- Step 3:** Cubic feet of sand \div 27 = yards of sand needed

EDGE RESTRAINT CALCULATIONS:

The following formula is used to calculate the amount of edging.

- Step 1:** Measure the total linear footage of job, less any existing edge (foundation, curbing, wall etc.)
- Step 2:** Total lineal feet of edge restraint required \div length of edging = total pieces of edge restraint required. Some rigid edge restraint pieces are 8'.
- Step 3:** Spikes required: Driveway 1 Per 1 L/F; walkway 1 Per 2 L/F



***Calculation formulas are provided as a service by Keystone Hardscapes for estimating material requirements. Keystone Hardscapes will not be held responsible in any way for resulting product overage or shortage.**



FREQUENTLY ASKED PAVER QUESTIONS

How are pavers made?

With Keystone Hardscapes, the strength and color goes all the way through the paver, so the color won't wear away. Keystone Hardscapes uses extremely high quality pigments to color our products. Unlike some pavers that have a thin "topcoat," Keystone Hardscapes pavers are colored throughout the entire paver. Because of the sun's ultraviolet rays some overall fading may occur on any paver.

How do I clean my pavers?

Keystone Hardscapes recommends using one of the many hardscape cleaners available on the market. Contact your local dealer for their recommendation on which cleaner is best for you.

Should I seal my pavers?

Sealers help in enhancing colors and resisting stains. There are a variety of sealers available, including some that are high gloss, and some that are matte surface. You must wait at least a full season before applying a sealer.

Will weeds grow up through the pavers?

Weeds do not grow up from below the pavers through the quarry process base. The growth of weeds and grasses results from airborne seeds. Ask your local dealer for their recommendations on which type of weed killer to use for your particular application. For best results, use a polymeric sand during the installation of your pavers to eliminate weeds, ants, etc.

What is efflorescence?

Efflorescence is a whitish powder-like deposit which sometimes appears on concrete and clay products. The deposit is the residue of a soluble salt (inherent in concrete products) carried to the face of the product by moisture and left on the surface as a dried white powder. Efflorescence is completely natural and will disappear with time.

What should I do about de-icing?

Keystone Hardscapes pavers are high-density units that resist deterioration from freeze-thaw cycles and de-icing salts better than asphalt, ordinary poured-in-place concrete and stamped concrete. Pavers meet or exceed 8,000 psi (which is about three times stronger than regular concrete) and are more resistant to de-icers, but NO concrete product is immune to long term effects. The recommended salts are calcium chloride. Also acceptable are magnesium chloride and sodium chloride. Snow removal is the same as with other pavements. Just plow, shovel or use a snow blower.

Can I pick the color of my Keystone Hardscapes pavers from the color sales literature?

Keystone Hardscapes products are made from natural materials, which have variations in colors and shades. The color photos are prepared with great concern for accuracy. Because photo reproductions cannot precisely convey the color of the actual product, we strongly encourage you to visit an authorized Keystone Hardscapes dealer.

Can I use stone dust under my pavers for the setting bed?

No. Most stone dust has too many fine particles that slow drainage and rut under repeated loads from tires. These small particles hold excessive amounts of water, causing the bedding layer to become saturated. This liquefied layer then becomes unstable and can even pump out of the joints. Concrete sand is recommended. It's the same sand mixed into concrete pavers and poured, cast-in-place concrete. This type of sand is readily available from your local supplier. Most suppliers may refer to this product as washed concrete sand.

What are permeable pavers?

Permeable interlocking concrete pavement (PICP) is comprised of a layer of concrete pavers separated by joints filled with small stones. Water enters joints between solid concrete pavers and flows through an "open-graded" base, i.e. crushed stone layers with no small or fine particles. The void spaces among the crushed stones store water and infiltrate back into the soil subgrade. The stones in the joints provide 100% surface permeability and the base filters stormwater and reduces pollutants.

Do you install permeable pavers just like regular pavers?

No. Permeable Pavers are installed over an open-graded stone aggregate base with no fines. Standard pavers are installed over a crushed stone base with a sand setting bed.

Are permeable pavers worse or better than regular pavers in winter conditions?

When the sun and temperature are right, ice and snow on PICPs can melt and immediately soak into the pavement surface. Water does not collect on the surface and re-freeze. This reduces slipping hazards. Sand should not be used for foot or tire traction on PICP. De-icing salts can be used. After plowing, melting of any remaining snow can occur if the temperature rises above freezing. This will help eliminate ice from forming and reduce salt contamination in groundwater. They have the same ability to accept snow plows and blowers without paver damage.

Are there different kinds of permeable pavers?

There are grass pavers which can have vegetation planted in the holes or voids. Keystone Hardscapes calls theirs TurfStone. Interlocking concrete pavers are a popular choice in permeable paving. They are filled with open-graded stone aggregates. Keystone Hardscapes manufactures many options of permeable pavers.

Does the surface conform to the Americans with Disabilities Act (ADA) requirements?

Yes. ADA Design Guidelines require that surfaces be firm, stable and slip resistant. PICP designs can provide a firm and stable surface for visually impaired persons and those using wheeled mobility devices. If the openings in the surface are not desirable, solid units can be used.

How is a PICP surface cleaned and how often?

The openings in the surface of PICPs will require periodic removal of detritus and sediment trapped by the small sized crushed stone. Dirt is typically removed by a vacuum-sweeping street cleaning machine. Cleaning is done when the pavement surface and detritus are dry and can be loosened by sweeping and vacuuming. The frequency of cleaning will vary with the use of the pavement and position of the sediment, leaves, etc. from adjacent areas. Cleaning should be done at least once a year, and the surface monitored during the early life of the pavement so that a regular cleaning schedule can be established.

PAVER CALCULATION FORMULA

These 5 patterns can be made out of Holland Stone or any of the rectangular shaped pavers.

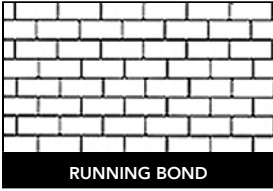

RUNNING BOND

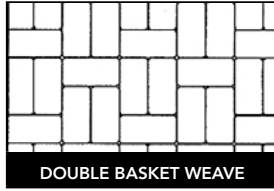

DOUBLE BASKET WEAVE

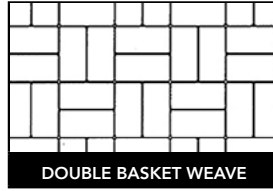

DOUBLE BASKET WEAVE

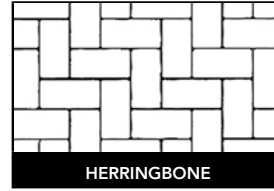

HERRINGBONE



45 DEGREE HERRINGBONE

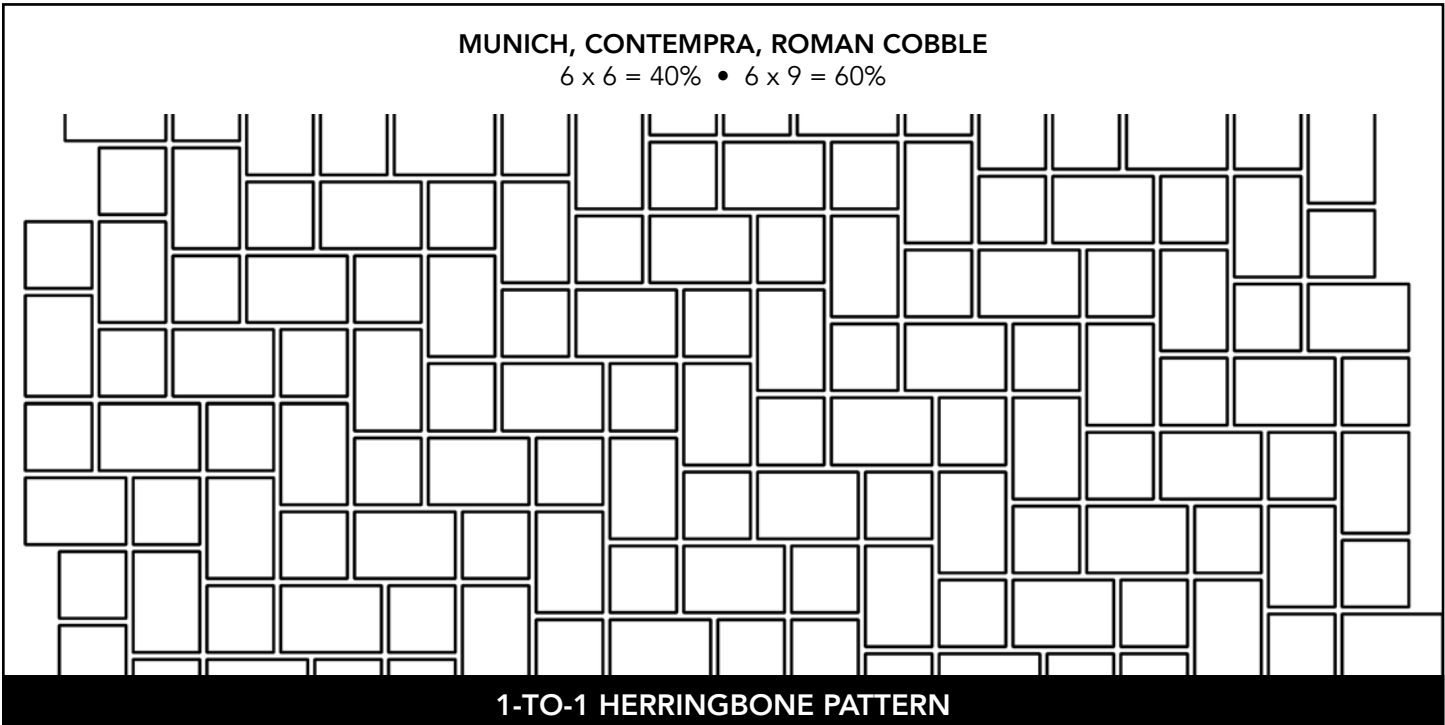

1-TO-1 HERRINGBONE PATTERN

Paver Calculation Formula

I. Total Area (square footage)	(I) _____	Sq. ft.
II. Total Border (linear footage)	(II) _____	Ln. ft.
a. Convert Ln. ft. to # of pavers	(IIa) _____	Pavers
b. Convert # of pavers to sq. ft.	(IIb) _____	Square foot
c. Field area = total area (sq. ft.)	(I) _____	Total area (sq. footage)
Subtract Border (sq. footage)	minus (IIc) _____	Border (sq. footage)
	equals _____	Field area (sq. footage)

III. Calculate Pattern Ratio Using Field Area

Paver _____	Size 5 (%)	x (Field Area) = _____	sq. ft. = _____	Cubes _____	Bands _____
Paver _____	Size 5 (%)	x (Field Area) = _____	sq. ft. = _____	Cubes _____	Bands _____
Paver _____	Size 5 (%)	x (Field Area) = _____	sq. ft. = _____	Cubes _____	Bands _____
Paver _____	Size 5 (%)	x (Field Area) = _____	sq. ft. = _____	Cubes _____	Bands _____
Paver _____	Size 5 (%)	x (Field Area) = _____	sq. ft. = _____	Cubes _____	Bands _____
Border (sq. footage from above) =			sq. ft. = _____	Cubes _____	Bands _____

KEYSTONE COMPAC® III

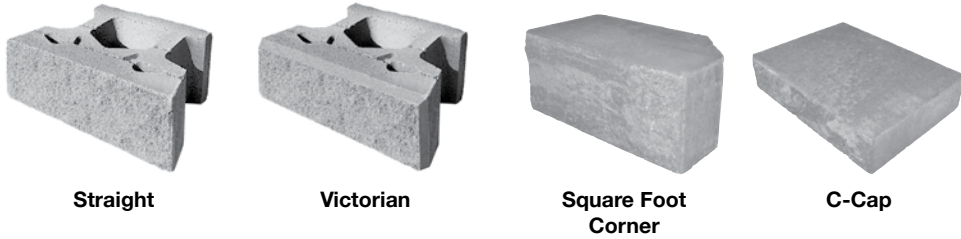

DIMENSIONS

KEYSTONE COMPAC III					
Product	Straight	Victorian	Square Foot Corner	C-Cap (Branchville)	C-Cap (Montgomery)
Height (in.)	8	8	8	3 5/8	3 5/8
Width (in.)	18	18	18	16	16
Depth (in.)	12	12	9	12	12
Weight/Unit (lbs.)	78	78	100	57	57
Sq. Face Ft./Cube	32	32	NA	19.2	18
Units/Cube	32	32	20	48	45
Weight/Cube (lbs.)	2,546	2,546	2,000	2,740	2,569
Part #	11017078	11017878 + Color	VSFCR	VCC	VCC

NOTES: There is a 6' minimum radius on Compac III. Available in standard finish only.



Pins - #995-000224
(Box of 100)
2 connection pins required per unit.
Pins allow for near-vertical or battered setback construction options.

Pins: 1/2" W x 5 1/4" L • Fiberglass connection pins



PRODUCT DETAILS

- The Compac III design results in decreased unit weight; effectively reducing shipping costs while maintaining structural integrity.
- Allows for positive connection with reinforcement to build engineered walls in excess of 60 feet tall.
- Vertically aligned cores allows for ease of core filling and increases vertical drainage through face units.
- Unit shape allows for tight radius curves and vertical core alignment.
- Shorter tail design makes for easier handling in the field.
- Triangular shaped pin receiving hole allows for installer-friendly construction adjustments.
- Near vertical or battered setback construction options.
- Variety of colors complement any landscape.
- Natural stone texture appearance.
- Capping and corner units available.

Standard Colors								
03 Antique Grey	46 Bedford Brown	09 Brown Flash	36 Butternut	47 Hickory Blend	55 North Creek (C-Cap Only)	24 Pecan Blend	06 Raven Black (C-Cap Only)	05 Red Flash

*Limited availability; large orders are special order.

INSTALLATION INSTRUCTIONS FOR KEYSTONE COMPAC® III

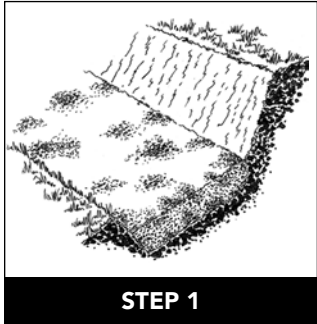

STEP 1

Prepare the Base Leveling Pad.

Excavate the base trench to the designed width and depth. Start the leveling pad at the lowest elevation along the wall alignment. Step up in 8" increments with the base as required at elevation change in the foundation. Level the prepared base with maximum lifts of 6" of well compacted granular fill (gravel, road base, or 1/2" to 3/4" crushed stone). Compact to 95% Standard Proctor or greater. Do not use PEA GRAVEL or SAND for leveling pad.

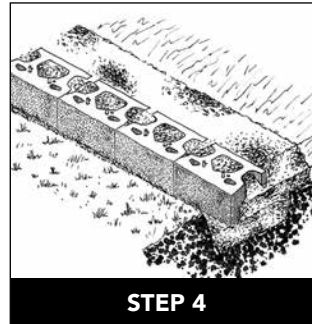

STEP 4

Install Fill & Compaction.

Provide 1/2" - 3/4" clean crushed stone drainage fill behind the units to a minimum distance behind the tail of one foot. Fill all open spaces between units and open cores with the same drainage material. Proceed to place backfill in maximum 6-8" layers and compact to 95% Standard Proctor with the appropriate compaction equipment.

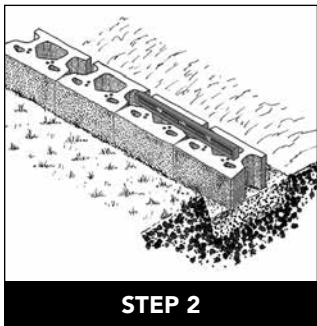

STEP 2

Install the Base Course.

Place the first course of Keystone units end to end (with face of wall corners touching) on the prepared base. The receiving pin holes should face upward, as shown. Make sure each unit is level front to back and left to right. Leveling the first course is critical for accurate and acceptable results. Minimum embedment depth below grade is 6". Consult wall design details for site specific embedment requirements.

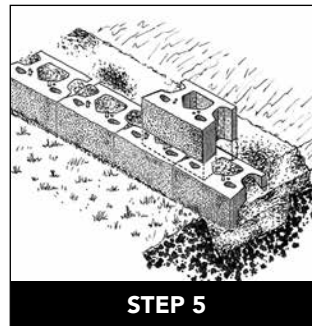

STEP 5

Install Additional Courses.

Clean any debris off the top course of units. Place the next course of Keystone units over the fiberglass pins, fitting the pins into the triangular shaped receiving hole in the units above. Push the units toward the face of the wall until they make full contact with the pins. Continue backfilling and building to desired top elevation.

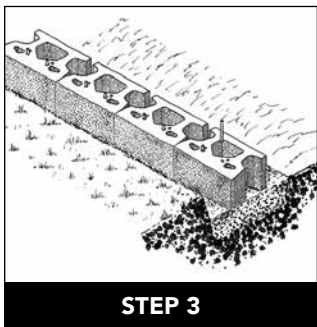

STEP 3

Insert the Fiberglass Pins.

Place the straight fiberglass pins into the holes of each Keystone unit as required. Once placed, the pins create an automatic setback for the additional courses. Place pins in the front holes for near vertical (1/8") setback and the rear holes for 1 1/8" setback per course.

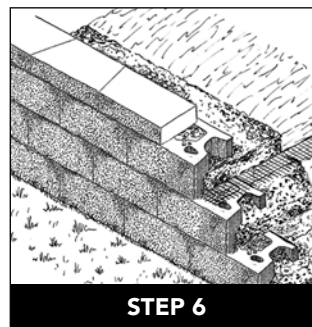

STEP 6

Capping the Wall.

Complete your wall with the appropriate Keystone capping units. With units dry and clean, use exterior construction grade adhesive on the top surface of the last course before applying cap units. Backfill and compact to finish grade.

NOTES: If drain tile is required for your project, consult an engineer or visit www.keystonehardscapes.com for more information. Colors are shown as accurately as possible in brochures and samples, but due to the nature of the product, regional color differences and variables in print reproduction, colors may not match exactly.

KEYSTONE STANDARD® III - STRAIGHT

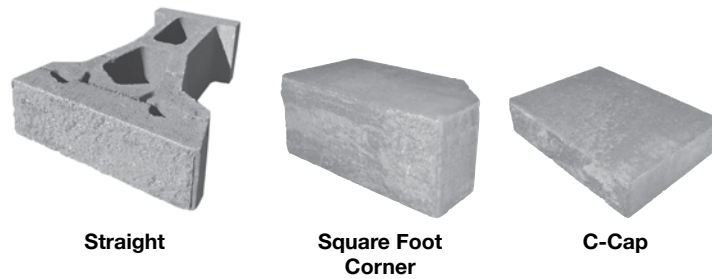

DIMENSIONS

KEYSTONE STANDARD III				
Product	Straight	Square Foot Corner	C-Cap (Branchville)	C-Cap (Montgomery)
Height (in.)	8	8	3 5/8	3 5/8
Width (in.)	18	18	16	16
Depth (in.)	21	9	12	12
Weight/Unit (lbs.)	105	100	57	57
Sq. Face Ft./Cube	16	NA	19.2	18
Units/Cube	16	20	48	45
Weight/Cube (lbs.)	1,714	2,000	2,740	2,569
Part #	11017378	VSFCR	VCC	VCC

NOTES: RockFace and Medley face styles are available by special order. Available in standard finish only.



Pins - #995-000224
(Box of 100)
2 connection pins required per unit.
Pins allow for near-vertical or battered setback construction options.

Pins: 1/2" W x 5 1/4" L • Fiberglass connection pins

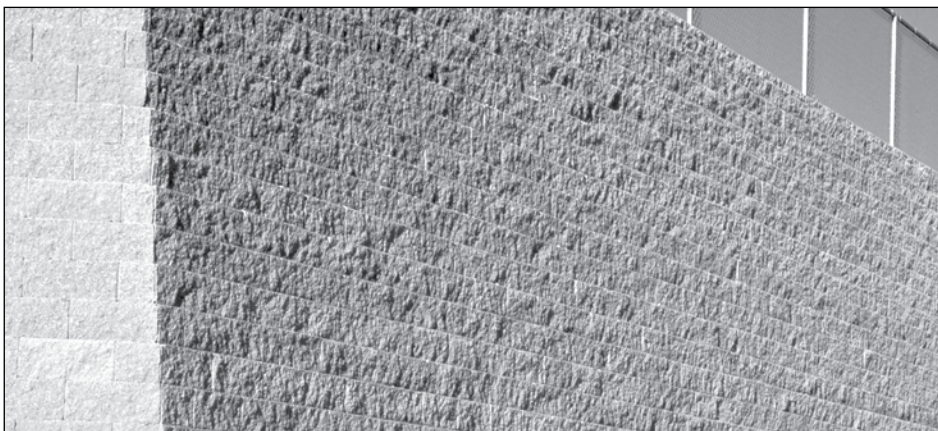

PRODUCT DETAILS

- Height-to-depth ratio delivers superior construction stability, durability, and strength.
- Higher unit-to-unit shear resistance.
- Open cores allow for gravel interlock across block interfaces.
- Near vertical or battered installation options.
- The 21" unit depth allow for higher gravity wall construction.
- Trapezoidal shaped sides offer ease in constructing radii.
- Tail design shape makes for easier handling in the field.
- Triangular shaped pin connection hole allows for installer-friendly construction adjustments.
- The Standard III design results in decreased unit weight when compared to the original Standard unit.
- Crisp and distinctive, the straight split face effectively showcases the color within each unit and a clean linear look.
- Variety of colors complement any landscape.
- Natural stone texture appearance.
- Capping and corner units available.

Standard Colors								
03 Antique Grey	46 Bedford Brown	09 Brown Flash	36 Butternut	47 Hickory Blend	55 North Creek	24 Pecan Blend	06 Raven Black	05 Red Flash
•				•	• (C-Cap Only)	•	• (C-Cap Only)	

*Limited availability; large orders are special order.

INSTALLATION INSTRUCTIONS FOR KEYSTONE STANDARD® III

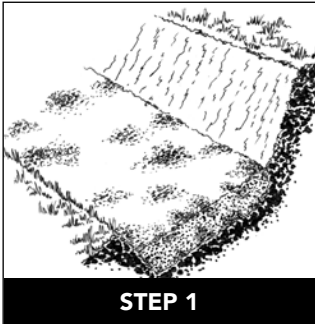

Prepare the Base Leveling Pad.
Excavate the base trench to the designed width and depth. Start the leveling pad at the lowest elevation along the wall alignment. Step up in 8" increments with the base as required at elevation change in the foundation. Level the prepared base with maximum lifts of 6" of well compacted granular fill (gravel, road base, or 1/2" to 3/4" crushed stone). Compact to 95% Standard Proctor or greater. Do not use PEA GRAVEL or SAND for leveling pad.

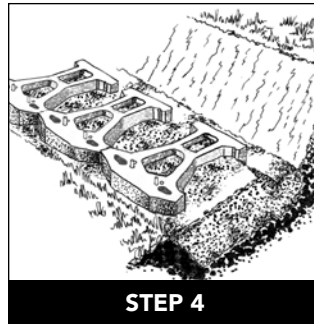

Install Fill & Compaction.
Provide 1/2" - 3/4" clean crushed stone drainage fill behind the units to a minimum distance behind the tail of one foot. Fill all open spaces between units and open cavities/cores with the same drainage material. Proceed to place backfill in maximum 6-8" layers and compact to 95% Standard Proctor with the appropriate compaction equipment.

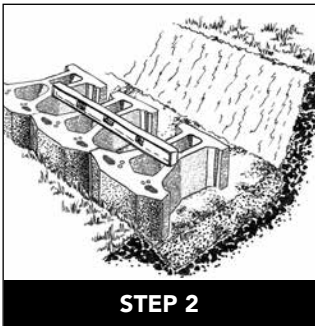

Install the Base Course.
Place the first course of Keystone units end to end (with face of wall corners touching) on the prepared base. The receiving pin holes should face upward, as shown. Make sure each unit is level front to back and left to right. Leveling the first course is critical for accurate and acceptable results. Minimum embedment depth below grade is 6". Consult wall design details for site specific embedment requirements.

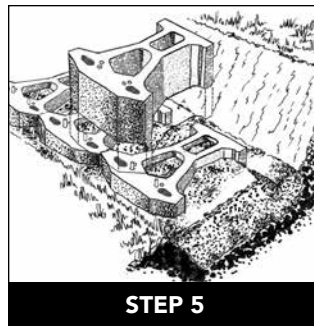

Install Additional Courses.
Clean any debris off the top course of units. Place the next course of Keystone units over the fiberglass pins, fitting the pins into the triangular shaped receiving hole in the units above. Push the units toward the face of the wall until they make full contact with the pins. Continue backfilling and building to desired top elevation.

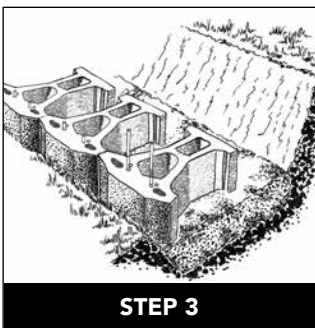

Insert the Fiberglass Pins.
Place the straight fiberglass pins into the holes of each Keystone unit as required. Once placed, the pins create an automatic setback for the additional courses. Place pins in the front holes for near vertical (1/8") setback and the rear holes for 1 1/8" setback per course.

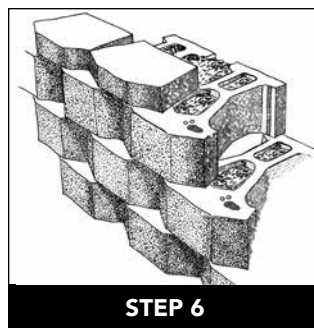

Capping the Wall.
Complete your wall with the appropriate Keystone capping units. With units dry and clean, use exterior construction grade adhesive on the top surface of the last course before applying cap units. Backfill and compact to finish grade.

NOTES: If drain tile is required for your project, consult an engineer or visit www.keystonehardscapes.com for more information. Colors are shown as accurately as possible in brochures and samples, but due to the nature of the product, regional color differences and variables in print reproduction, colors may not match exactly.

REGAL STONE PRO®

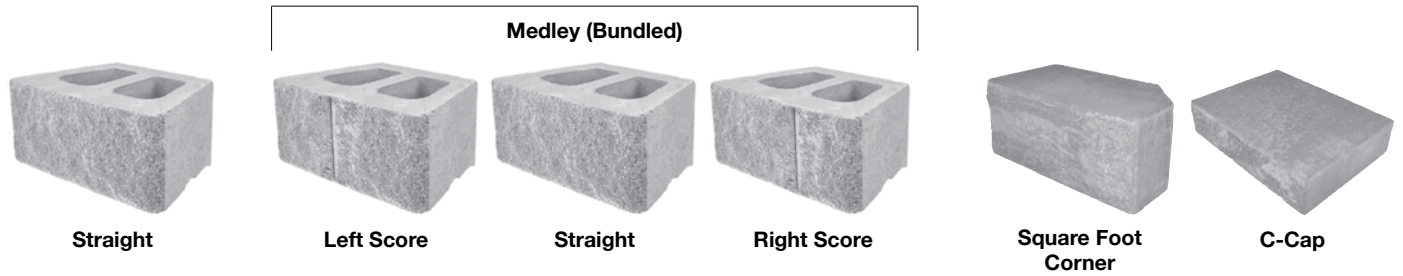

DIMENSIONS

REGAL STONE PRO		Medley (Bundled)					
Product	Straight	Left Score	Straight	Right Score	Square Foot Corner	C-Cap (Branchville)	C-Cap (Montgomery)
Height (in.)	8	8	8	8	8	3 5/8	3 5/8
Width (in.)	18	18	18	18	18	16	16
Depth (in.)	12	12	12	12	9	12	12
Weight/Unit (lbs.)	74	74			100	57	57
Sq. Face Ft./Cube	32	32			NA	19.2	18
Units/Cube	32	8	16	8	20	48	45
Weight/Cube (lbs.)	2,360	2,360			2,000	2,740	2,569
Part #	82778+color	88878+color			VSF CR	VCC	VCC

NOTE: Available in standard finish only.



PRODUCT DETAILS

- Made of durable concrete with iron oxide pigments that resist fading in extended UV exposure. Meets or exceeds applicable requirements of ASTM C1372 for compressive strength, absorption and dimensional tolerance.
- Able to build engineered walls in excess of 60' tall.
- Rear lips ensure setback and ease of installation.
- Unit cores reduce product weight and shipping cost and make it easy to handle.
- Scored and straight split units combine to achieve the beauty of a three-piece stone system with the efficiencies of a single unit installation.
- Rugged exterior evokes the look and feel of naturally weathered stone.
- Cap and corner units available.
- Variety of colors complement any landscape.

Standard Colors								
03 Antique Grey	46 Bedford Brown	09 Brown Flash	36 Butternut	47 Hickory Blend	55 North Creek	24 Pecan Blend	06 Raven Black (C-Cap Only)	05 Red Flash

INSTALLATION INSTRUCTIONS FOR REGAL STONE PRO®

STEP 1: Layout - Stake out the wall's placement according to lines and grades on approved plans. Excavate for the leveling pad to the lines and grades shown. Excavate soil to a dimension behind the wall for placement of grid and reinforced soils.

STEP 2: Leveling Pad - The leveling pad consists of a crushed aggregate compactible base material. The pad must extend a minimum six (6) inches in front and behind the first course of unit, and be a minimum six (6) inches in depth. Compact the aggregate and check top elevation for level.

STEP 3: Base Course - Place a string line along the back of the unit to align the wall units. Begin laying unit at the lowest elevation of the wall. Place wall units flat on the leveling pad with facings aligned according to plans. If necessary, remove rear lip of the unit so that it will lie flat on the leveling pad. Place the units side-by-side, flush against each other, and in full contact with the leveling pad. Level the unit front-to-back and side-to-side. Check the units for proper horizontal alignment.

STEP 4: Wall Construction - Clean any debris off the top of the units. Place the second course of units on the base course maintaining running bond pattern (do not align vertical joints). Push each unit forward as far as possible to ensure unit-to-unit engagement and the correct setback. Fill all voids between and within concrete wall units with drainage aggregate. Backfill with drainage aggregate directly behind the unit to a depth of 24" from the face of the wall. Fill behind the aggregate with soil meeting design parameters. Place and compact the backfill material before the next course is laid. Hand-operated equipment should be used within three (3) feet of the wall. Avoid driving heavy equipment within three (3) feet of the wall units.

STEP 5: Drainage - Place a perforated drain pipe at the base of the drainage aggregate. Daylight or direct the drain to an area lower than the lowest drain elevation in the wall. Additional drainage design may be required.

STEP 6: Install Fill and Compaction - Place the drainage aggregate and unit core fill as directed. Place reinforced backfill soil behind the drainage aggregate in maximum 6-8" lifts and compact to a minimum of 95% standard Proctor density with the appropriate compaction equipment.

STEP 7: Geogrid Reinforcement Placement - Check approved wall construction plan for grid placement lengths, elevations and strengths. Measure and cut the reinforcement geogrid to the design length in the plans. The design strength direction of the geogrid shall be laid perpendicular to the wall. Place the front edge of the geogrid on

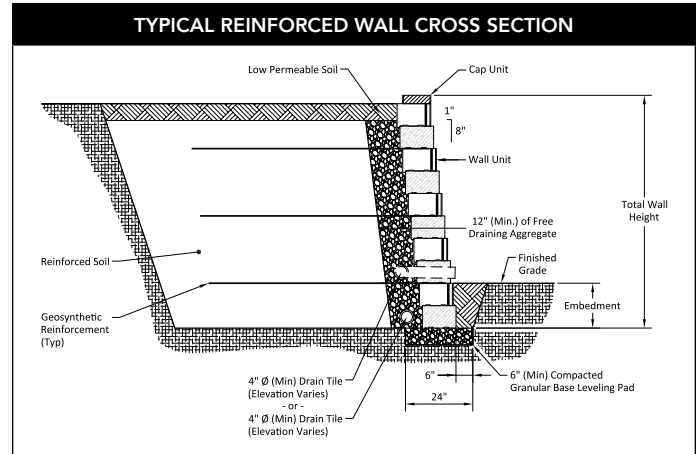

the designated course a maximum of one (1) inch from the face of the unit. Apply the next course of units to secure it in place. Pull the reinforcement taut and secure in place. A minimum of six (6) inches of backfill over the grid is required prior to vehicular operation.

Repeat steps 4 to 7 as required to reach the top of wall elevation.

STEP 8: Cap Placement - Thoroughly clean the top course of wall units. Dry set the caps on the wall units using a string line to obtain the proper horizontal alignment. Cut caps to fit as needed. Adhere the cap units to the wall units with a sufficient amount of an exterior concrete adhesive.

STEP 9: Finish Grade and Surface Drainage - Protect your wall from water damage and erosion with a finished grade to provide positive drainage away from the wall at the top and bottom of the wall structure during construction. To minimize infiltration of water into the top of the backfill area of the wall, place a minimum of eight (8) inches of soil with low permeability (clay or similar materials) over the drainage aggregate and backfill soils.

NOTE: Colors are shown as accurately as possible in brochures and samples, but due to the nature of the product, regional color differences and variables in print reproduction, colors may not match exactly.

VERSA-LOK® SQUARE FOOT™



Square Foot



Square Foot Corner

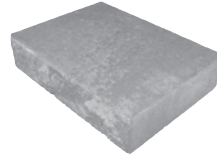

C-Cap



VL Pins
2 required per unit

DIMENSIONS

VERSA-LOK SQUARE FOOT

Product	Square Foot (Branchville)	Square Foot (Montgomery)	Square Foot Corner	C-Cap (Branchville)	C-Cap (Montgomery)
Height (in.)	8	8	8	3 5/8	3 5/8
Width (in.)	18	18	18	16	16
Depth (in.)	12	12	9	12	12
Weight/Unit (lbs.)	84	84	100	57	57
Sq. Face Ft./Cube	32	32	NA	19.2	18
Units/Cube	32	32	20	48	45
Weight/Cube (lbs.)	2,689	2,689	2,000	2,740	2,569
Part # (Standard)	VSF	VSF	VSFCR	VCC	VCC
Part # (Weathered)	VSF_T	VSF_T	VSFCR_T	VCC_T	VCC_T

VERSA-LOK PINS

Glass-reinforced nylon

Product	Bag of 100	Case of 500	Full Pallet
Length (in.)	6.8		
Width (in.)	1/2		
Weight (lbs.)	4	20	950
Units/Cube	100/bag	500/Case	48 Cases
Part #	PIN1B	PIN1C	PIN1

NOTE: Available in standard and weathered finishes.

PRODUCT DETAILS

- Square Foot units are made from high-strength, low-absorption concrete on concrete block machines. Each unit covers one square foot of wall face, making Square Foot retaining walls an economical choice for large commercial and agency projects. They are routinely used by many state transportation departments.
- All VERSA-LOK retaining wall units are made to ASTM C1372 standard specifications of segmental retaining wall units.
- Square Foot units use the same caps and VERSA-LOK pins as the Standard units.
- Square Foot Corner calculations use both exposed faces of the corner stone. The minimum concave and convex radius for Square Foot units is 4' 6".
- Square Foot retaining walls are economically installed and mechanically fastened without mortar and do not require concrete footings. Like VERSA-LOK Standard, a pinning system is used.

Standard Colors								
03 Antique Grey	46 Bedford Brown	09 Brown Flash	36 Butternut	47 Hickory Blend	55 North Creek	24 Pecan Blend	06 Raven Black (C-Cap Only)	05 Red Flash
•	•	•*	•	•	•		•	•*

*Limited availability

VERSA-LOK® SQUARE FOOT SYSTEM OVERVIEW

Pinning Detail

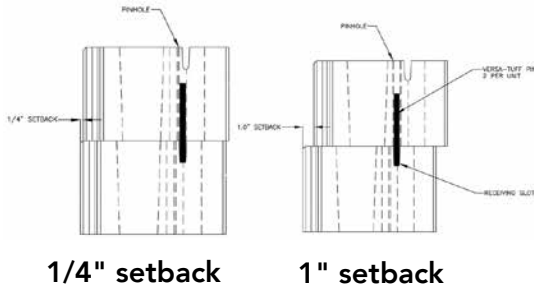

PINNING

VERSA-LOK Square Foot units interlock with non-corrosive VERSA-TUFF Pins (two per unit). As wall courses are installed, pins are inserted through holes in uppermost course units and are received in slots of adjacent lower course units. Receiving slots allow pinning for near vertical ($\frac{1}{4}$ " setback) or canted (1" setback) walls.



Unreinforced Wall

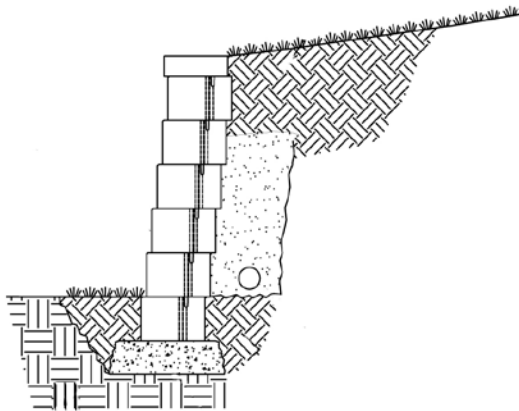

UNREINFORCED WALLS

For shorter walls, Square Foot retaining walls work purely as gravity systems - unit weight alone provides resistance to earth pressures. Batter setback of wall faces offers additional resistance against overturning. Maximum allowable wall height for gravity walls varies with soil and loading conditions. Generally, with level backfill, good soils, and no excessive loading, Square Foot gravity walls are stable to heights of three (3) feet.

Reinforced Wall

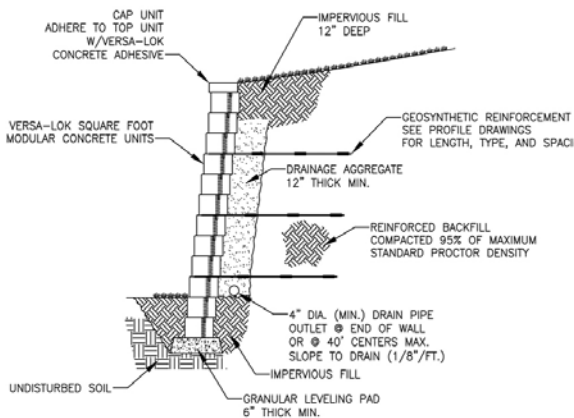

REINFORCED WALLS

When weight of units alone is not enough to resist soil loads, horizontal layers of geosynthetics are used to reinforce soil behind walls. With proper soil reinforcement and design, Square Foot retaining walls can be constructed to heights in excess of 50 feet. Geosynthetics and soil combine to create reinforced soil structures that are strong and massive enough to resist forces exerted on them.



VERSA-LOK® STANDARD



Standard



Full Corner

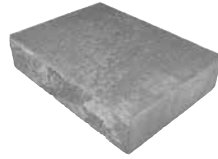

C-Cap



VL Pins

2 required per unit

DIMENSIONS

VERSA-LOK STANDARD

Product	Standard (Branchville)	Standard (Montgomery)	Full Corner	C-Cap (Branchville)	C-Cap (Montgomery)
Height (in.)	6	6	6	3 5/8	3 5/8
Width (in.)	16	16	16	16	16
Depth (in.)	12	12	8	12	12
Weight/Unit (lbs.)	82	82	100	57	57
Sq. Face Ft./Cube	32	30	NA	19.2	18
Units/Cube	48	45	20	48	45
Weight/Cube (lbs.)	3,950	3,703	2,000	2,740	2,569
Part # (Standard)	VST	VST	VFCR	VCC	VCC
Part # (Weathered)	VST_T	VST_T	VFCR_T	VCC_T	VCC_T

PRODUCT DETAILS

- Standard units are made from high-strength, low-absorption concrete on concrete block machines. The Standard units' solid characteristics make them resistant to damage before, during and after construction in all climates, including shoreline applications.
- All VERSA-LOK retaining wall units are made to ASTM C1372 standard specifications of segmental retaining wall units.
- When making a curve with VERSA-LOK Standard units, the minimum outside radius is 8 feet at the top of the wall. The 3/4" setback of each unit creates a cant of approximately 7 degrees. Canted walls are structurally more stable than vertical walls because the gravitational forces pull walls into retained soil.

VERSA-LOK PINS

Glass-reinforced nylon

Product	Bag of 100	Case of 500	Full Pallet
Length (in.)	6.8		
Width (in.)	1/2		
Weight (lbs.)	4	20	950
Units/Cube	100/bag	500/Case	48 Cases
Part #	PIN1B	PIN1C	PIN1

NOTE: Available in standard and weathered finishes.



Standard Colors

03
Antique Grey



46
Bedford Brown



09
Brown Flash



36
Butternut



47
Hickory Blend



55
North Creek



24
Pecan Blend



06
Raven Black



(C-Cap Only)

05
Red Flash



*Limited availability

VERSA-LOK® STANDARD SYSTEM OVERVIEW

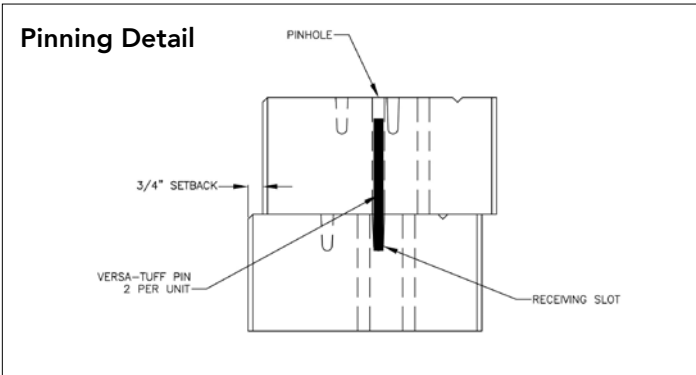

PINNING

VERSA-LOK Standard units have a unique hole-to-slot pinning system for easy installation and superior structural integrity. VERSA-LOK Standard units interlock with non-corrosive VERSA-TUFF Pins (two per unit). As wall courses are installed, pins are inserted through holes in uppermost course units and are received in slots of adjacent lower course units. Pinning helps to align units in a consistent 3/4" setback per course.

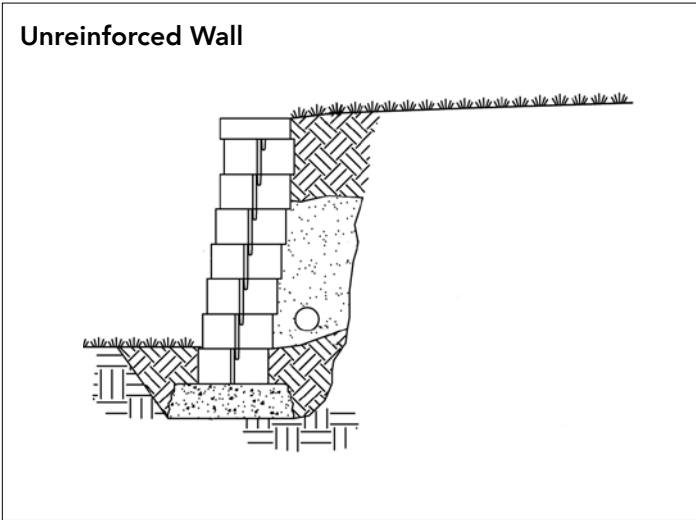
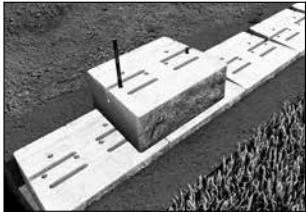

UNREINFORCED WALLS

On many projects, VERSA-LOK Standard retaining walls work purely as gravity systems - unit weight alone provides resistance to earth pressures. Frictional forces between units and pin connections hold units together so walls behave as coherent structures. Batter setback of wall faces offers additional resistance against overturning. Maximum allowable wall height for gravity walls varies with soil and loading conditions. Generally, with level backfill, good soils, and no excessive loading VERSA-LOK Standard gravity walls are stable to heights of four (4) feet.

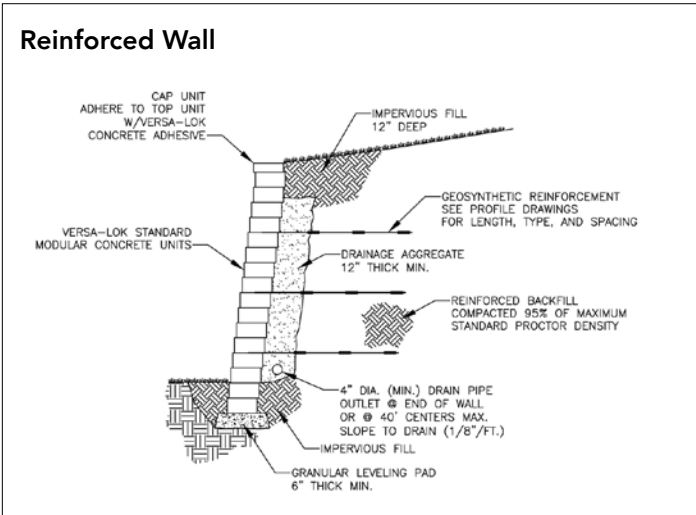

REINFORCED WALLS

When weight of units alone is not enough to resist soil loads, horizontal layers of geosynthetics are used to reinforce soil behind walls. With proper soil reinforcement and design, VERSA-LOK Standard walls can be constructed to heights in excess of 40 feet. Geosynthetics do not act as tie-backs for wall faces. Rather, geosynthetics and soil combine to create reinforced soil structures that are strong and massive enough to resist forces exerted on them. In soil-reinforced walls, Standard units simply retain soil between layers of geosynthetics and provide attractive durable faces.



VERSA-LOK® MOSAIC®



Standard



Accent



Cobble

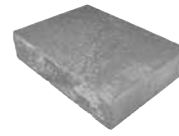

C-Cap



**Versa-Tuff
Snap Off Pins**
2 required per unit

DIMENSIONS

VERSA-LOK MOSAIC

Product	Standard (Branchville)	Standard (Montgomery)	Accent	Cobble	C-Cap (Branchville)	C-Cap (Montgomery)
Height (in.)	6	6	4	6	3 3/8	3 3/8
Width (in.)	16	16	12	8	16	16
Depth (in.)	12	12	12	12	12	12
Weight/Unit (lbs.)	82	82	37	38	57	57
Sq. Face Ft./Cube	32	30	32	30	19.2	18
Units/Cube	48	45	96	90	48	45
Weight/Cube (lbs.)	3,950	3,703	3,550	3,420	2,740	2,569
Part # (Standard)	VST	VST	VAC	VCO	VCC	VCC
Part # (Weathered)	VST_T	VST_T	VAC_T	VCO_T	VCC_T	VCC_T

PRODUCT DETAILS

- The Mosaic system provides design flexibility, durability, and ease of installation. Mosaic walls are quickly and economically assembled without mortar and do not require concrete footings. VERSA-LOK's unique hole-to-slot pinning system interlocks units and aids in alignment.
- One Standard, one Cobble, and two Accent units are arranged in ten inch high by 24 inch wide panels. There are four different panel configurations that can be arranged in any order to form a random appearance
- All VERSA-LOK retaining wall units are made to ASTM C1372 standard specifications of segmental retaining wall units.

VERSA-LOK PINS

Glass-reinforced nylon

Product	Bag of 100	Case of 500	Full Pallet
Length (in.)	6.8		
Width (in.)	1/2		
Weight (lbs.)	4	20	950
Units/Cube	100/bag	500/Case	48 Cases
Part #	PIN1B	PIN1C	PIN1

MOSAIC SYSTEM DESIGN PATTERN

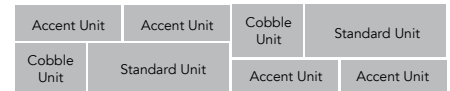

NOTE: Available in standard and weathered finishes.



Standard Colors

03 Antique Grey	46 Bedford Brown	09 Brown Flash	36 Butternut	47 Hickory Blend	55 North Creek	24 Pecan Blend	06 Raven Black (C-Cap Only)	05 Red Flash
•	•	•*	•	•	•		•	•*

*Limited availability

VERSA-LOK® MOSAIC® PANEL

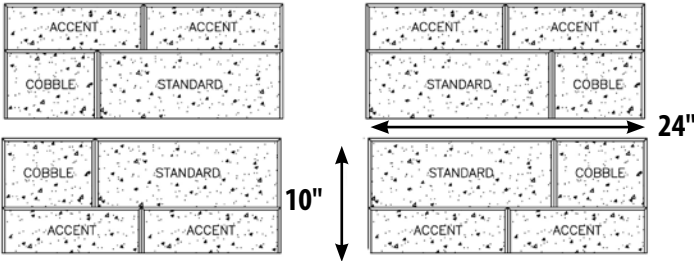

VERSA®-TUFF SNAP OFF PINS

VERSA-LOK Mosaic units interlock with non-corrosive VERSA-TUFF Snap-Off Pins (two per unit and eight per panel). The pins are inserted through front holes in the upper units into slots in the units below. Slots allow variation in location of vertical joints (variable bond). VERSA-TUFF Snap-Off Pins are designed to accommodate varied heights of Mosaic units. The full length of VERSA-TUFF Pins is used when pinning through six inch high Standard and Cobble units. When pinning through four inch high Accent units, the two inches of the VERSA-TUFF Pin remaining above the unit is easily snapped off.



Length:	6.8 inches	172.7 mm
Diameter:	.48 inches	12.2 mm
Material:	Glass-Reinforced Nylon	

Pinning Detail

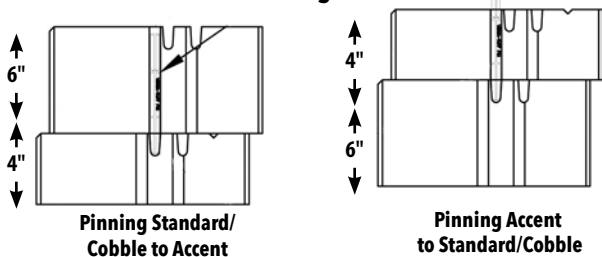

MOSAIC PINNING

On many projects, Mosaic retaining walls work purely as gravity systems, where unit weight, frictional forces between units, pins and the cant of the wall combine to provide resistance to earth pressures. With level backfill and no excessive loading, most Mosaic walls are stable to four (4) feet in height. When unit weight and frictional forces are not enough to resist soil loads, horizontal layers of geosynthetics are used to reinforce soil behind walls. With proper design and soil reinforcement, Mosaic walls can be constructed to heights exceeding 40 feet. Each Mosaic unit is set back 0.75 inch from the units beneath it. There are two units stacked in each ten-inch-high panel - a total setback of 1.5 inches per panel. This results in a cant of approx. 8.5 degrees from vertical.

Unreinforced Wall

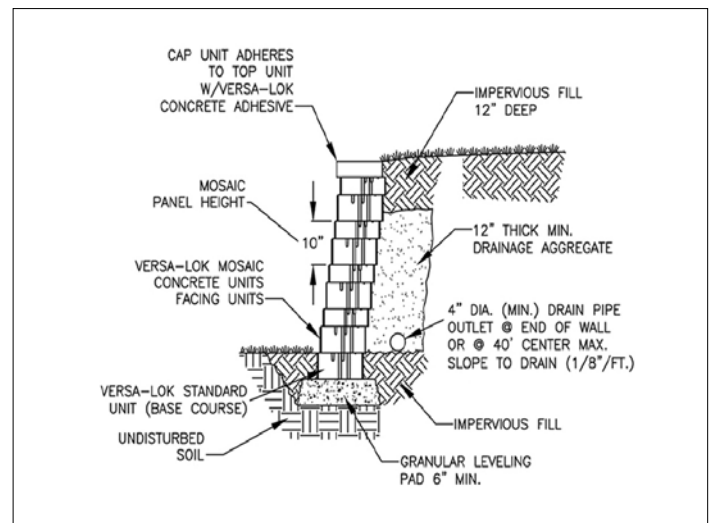

Reinforced Wall

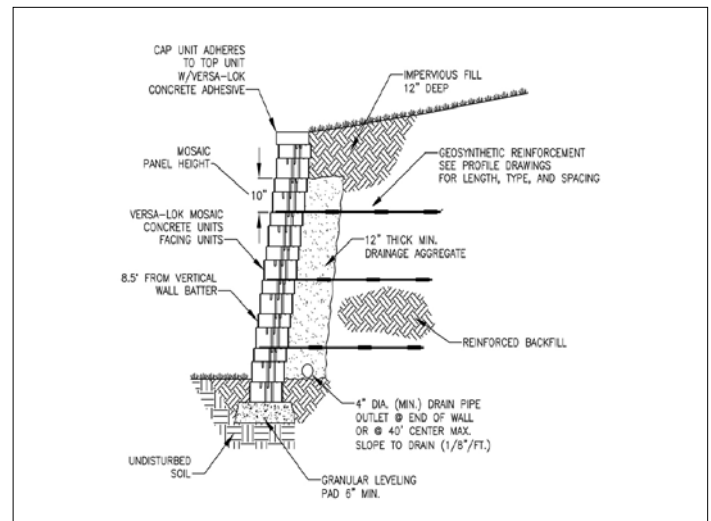

HARINGTON® - MEDLEY



DIMENSIONS

HARINGTON	Medley (Bundled)					
Product	Left Score	Straight	Right Score	Full Corner	C-Cap (Branchville)	C-Cap (Montgomery)
Height (in.)	6	6	6	6	3 ½	3 ½
Width (in.)	18	18	18	16	16	16
Depth (in.)	12	12	12	8	12	12
Weight/Unit (lbs.)	78	78	78	60	57	57
Sq. Face Ft./Cube	30			NA	19.2	18
Units/Cube	10	20	10	20	48	45
Weight/Cube (lbs.)	3,167			2,000	2,740	2,569
Part #	87078+color			VFCR	VCC	VCC

NOTE: Available in standard finish only.



PRODUCT DETAILS

- Made of durable concrete with iron oxide pigments that resist fading in extended UV exposure. Meets or exceeds applicable requirements of ASTM C1372 for compressive strength, absorption and dimensional tolerance.
- Perfect for gravity walls up to 4 ft. high with no surcharge loads or consult an engineer for higher reinforced walls or gravity walls with any surcharge loading.
- Rear lips ensure precise setback and alignment.
- Single unit size simplifies construction.
- Rustic RockFace finish evokes the look and feel of naturally weathered stone.
- Achieves the enhanced appearance of a multi-piece system.

Standard Colors								
03 Antique Grey	46 Bedford Brown	09 Brown Flash	36 Butternut	47 Hickory Blend	55 North Creek	24 Pecan Blend	06 Raven Black	05 Red Flash
•				•	•		• C-Cap Only	

INSTALLATION INSTRUCTIONS FOR HARINGTON®

STEP 1: Layout - Stake out the wall's placement according to lines and grades on approved plans. Excavate for the leveling pad to the lines and grades shown. Excavate soil to a dimension behind the wall for placement of grid and reinforced soils.

STEP 2: Leveling Pad - The leveling pad consists of a crushed aggregate compactible base material. The pad must extend a minimum six (6) inches in front and behind the first course of unit, and be a minimum six (6) inches in depth. Compact the aggregate and check top elevation for level.

STEP 3: Base Course - For gravity walls, one complete course of units must be buried. For taller reinforced walls, additional courses of block may need to be buried; consult the approved wall plans.

Place a string line along the back of the units to align the wall units. Begin laying unit at the lowest elevation of the wall. Place wall units flat on the leveling pad with facings aligned according to plans. If necessary, remove rear lip of the unit so that it will lie flat on the leveling pad. Place the units side-by-side, flush against each other, and in full contact with the leveling pad. Level the unit front-to-back and side-to-side. Check the units for proper horizontal alignment.

STEP 4: Wall Construction - Clean any debris off the top of the units. Units can be placed randomly in the wall without regard to bond. However, ensure that vertical joints do not line up on more than 2 courses. Push each unit forward as far as possible to ensure unit-to-unit engagement and the correct setback. Fill all voids between concrete wall units with drainage aggregate. Backfill with drainage aggregate directly behind the unit to a depth of 24" from the face of the wall.

STEP 5: Drainage - Place a perforated drain pipe at the base of the drainage aggregate. Daylight or direct the drain to an area lower than the lowest drain elevation in the wall. Additional drainage design may be required.

STEP 6: Install Fill and Compaction - Place the drainage aggregate and unit core fill as directed. Fill behind the aggregate with soil meeting design parameters. Place and compact the backfill material before the next course is laid. Hand-operated equipment should be used within three (3) feet of the wall. Avoid driving heavy equipment within three (3) feet of the wall units. Place reinforced backfill soil behind the drainage aggregate in maximum 6-8" lifts and compact to a minimum of 95% standard Proctor density with the appropriate compaction equipment.

STEP 7: Geogrid Reinforcement Placement - Check approved wall construction plan for grid type, strength, lengths and elevations. Measure

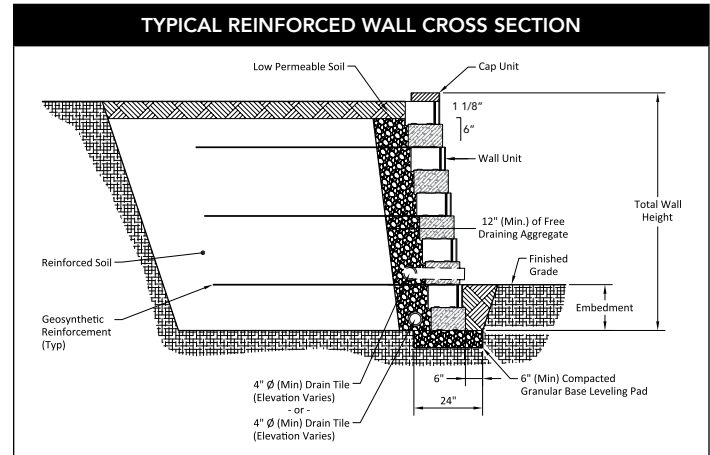

and cut the reinforcement grid to the design length in the plans. The design strength direction of the geogrid shall be laid perpendicular to the wall. Place the front edge of the geogrid on the designated course a maximum of one (1) inch from the face of the unit. Apply the next course of units to secure it in place. Pull the reinforcement taut and secure in place. A minimum of six (6) inches of backfill over the grid is required prior to vehicular operation.

STEP 8: Finish Grade and Surface Drainage - Protect your wall from water damage and erosion with a finished grade to provide positive drainage away from the wall at the top and bottom of the wall structure during construction. To minimize infiltration of water into the top of the backfill area of the wall, place a minimum of eight (8) inches of soil with low permeability (clay or similar materials) over the drainage aggregate and backfill soils.

NOTE: Colors are shown as accurately as possible in brochures and samples, but due to the nature of the product, regional color differences and variables in print reproduction, colors may not match exactly.



Wall Unit

Cap

DIMENSIONS

GARDEN WALL

Product	Wall Unit	Cap
Height (in.)	4	2
Width (in.)	11 5/8	12
Depth (in.)	8	8
Weight/Unit (lbs.)	22.5	14
Sq. Face Ft./Cube	48	120 Lin. ft.
Units/Cube	144	120
Weight/Cube (lbs.)	3,245	1,680
Pieces/Face Ft.	3	1
Part #	81178	81478

NOTE: Available in standard finish only.

PRODUCT DETAILS

- Hard split showcases fractured rock and the veining and contrast of blended colors
- Rear lips ensure precise setback and eliminate the material and labor costs of connectors
- Made of durable concrete iron oxide pigments that resist fading in extended UV exposure.

Standard Colors

03
Antique Grey

46
Bedford Brown

09
Brown Flash

36
Butternut

47
Hickory Blend

55
North Creek

24
Pecan Blend

06
Raven Black

05
Red Flash





Munich



**Munich
Small Radius**

DIMENSIONS

MUNICH WALL

Product	Munich	Small Radius
Height (in.)	4	4
Width (in.)	8	8*
Depth (in.)	12	8
Weight/Unit (lbs.)	30	16
Sq. Face Ft./Cube	40	48
Units/Cube	120	216
Weight/Cube (lbs.)	3,600	3,450
Pieces/Face Ft.	3	4.5
Part #	MW	MWS

PRODUCT DETAILS

- The square foot calculations of Munich Wall are using the 12" x 4" face.
- Munich Small Radius cubes contain enough pieces to build 3 fire pits that are 4 courses high.

NOTE: Available in weathered finish only. *The back side of the Small Radius unit is 5.5" wide.

Standard Colors								
03 Antique Grey	46 Bedford Brown	09 Brown Flash	36 Butternut	47 Hickory Blend	55 North Creek	24 Pecan Blend	06 Raven Black	05 Red Flash
•	•		• Special Order	•				

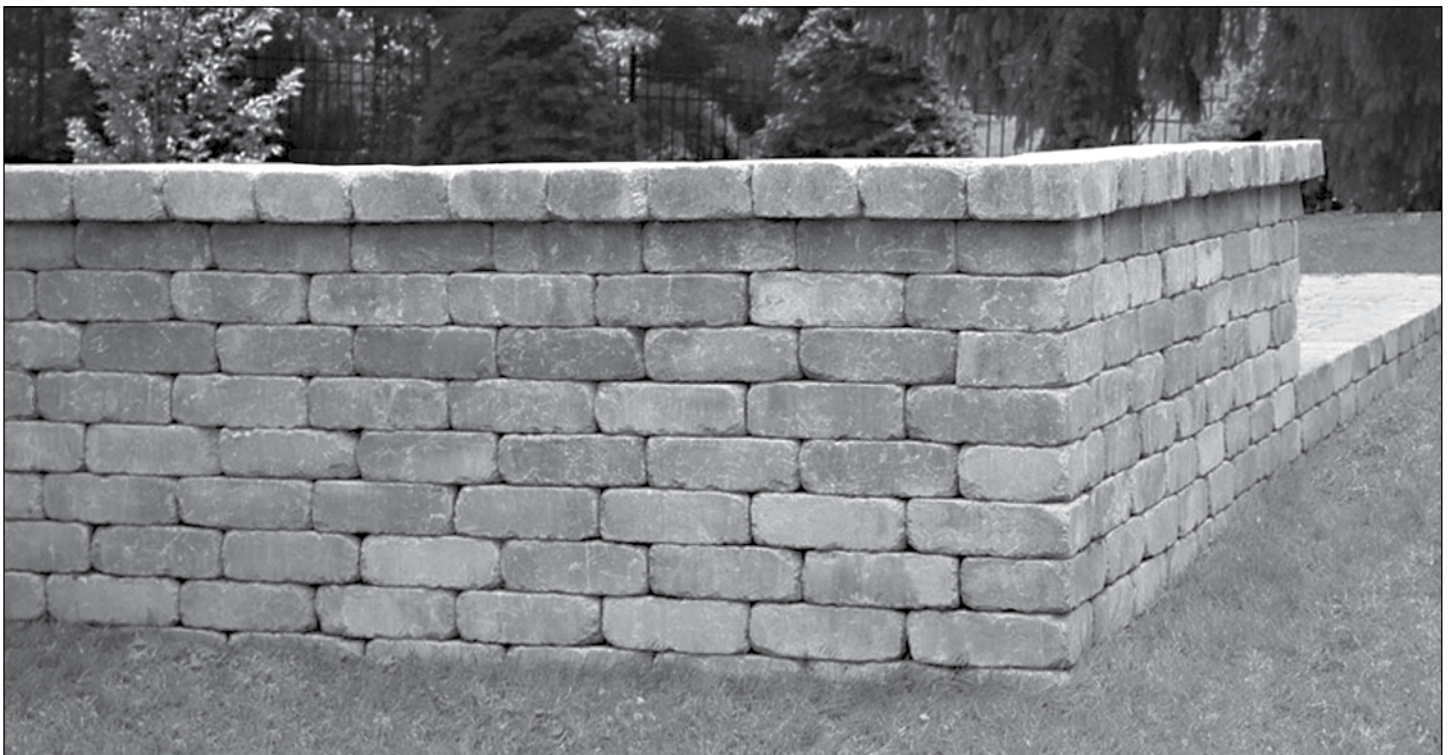

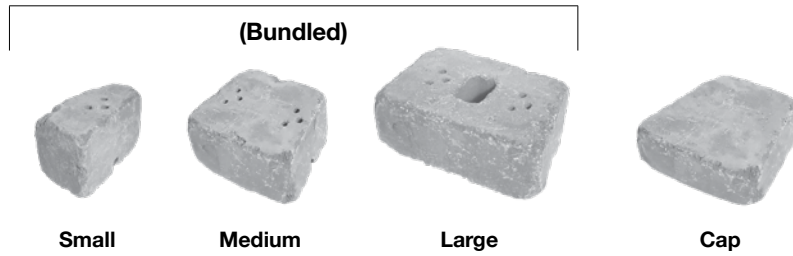

DIMENSIONS

STONEGATE	(Bundled)			
Product	Small	Medium	Large	Cap
Height (in.)	6	6	6	3
Width (in.)	6-4	12-10	16-14	12-10
Depth (in.)	10	10	10	11
Weight/Unit (lbs.)	22	49	63	30
Sq. Face Ft./Cube	25.8 (approx.)			NA
Units/Cube	20	20	20	60
Weight/Cube (lbs.)	2,870			1,836
Part # (Weathered)	11017678T			11017778T

NOTE: Available in weathered finish only.



Pins #995-000160
(Box of 100)

- The minimum radius that can be built using the random pattern of units is 4.5' (1.4m). To build a smaller radii, a larger proportion of small units is needed and some cutting may be required.
- Requires two pins for Large and Medium units; requires one pin for Small units (100 pins required per pallet.)
- Pin holes face up when installing.



PRODUCT DETAILS

- Perfect for gravity retaining walls up to 3' h. Higher heights can be reached with proper engineering and the use of geosynthetic reinforcement.
- Also perfect for parapet walls, pilasters, columns and stairs.
- Outdoor living designs: Fireplaces, fire pits, kitchens, benches and more.
- Multiple textured sides permit units to be installed as an exposed end unit or 90° corner.
- Each unit has three finished face dimensions; this design variation simplifies the creation of random patterns - assuring stunning results.
- Each unit's 90° angle and a tapered (angled) side, allow for the creation of 90° corners, tight fitting straight line walls, and radii at curves.
- Produced in colors that enhance its antiqued cut stone appearance.
- Artfully combines a smooth, weathered stone face with a rustic tumbled finish.
- Three finished face dimensions; this design variation simplifies the creation of random patterns and combines a smooth, weathered stone face with a rustic tumbled finish.

Standard Colors								
03 Antique Grey	46 Bedford Brown	09 Brown Flash	36 Butternut	47 Hickory Blend	55 North Creek	24 Pecan Blend	06 Raven Black	05 Red Flash

INSTALLATION INSTRUCTIONS FOR STONEGATE®



STEP 1



STEP 2



STEP 3



STEP 4



STEP 5



STEP 6

STEP 1:

Prepare the Base Leveling Pad.

Remove all surface vegetation and debris. Do not use this material as backfill. After selecting the location and length of the wall, excavate the base trench to the designed width and depth (min. 20" w x 12" d) [500mm x 300mm]. Start the leveling pad at the lowest elevation along wall alignment. Step up in 6" (150mm) increments with the base as required at elevation changes in the foundation. Level the prepared base with 6" (150mm) of well-compacted granular fill (gravel, road base, or ½" to ¾" [10 - 20 mm] crushed stone). Compact to 95% Standard Proctor or greater. Do not use PEA GRAVEL or SAND for leveling pad.

STEP 2:

Install the Base Course.

Place the first course of units end to end (with front corners touching) on the prepared base. The long groove (receiving channel) on the unit should be placed down and the three pin holes should face up, as shown. Make sure each unit is level - side to side and front to back. Leveling the first course is critical for accurate and acceptable results. For alignment of straight walls, use a string line aligned on the unit pin holes for accuracy. Minimum embedment of base course is 6" (152mm) below grade.

STEP 3:

Insert the Fiberglass Pins.

Place the shouldered fiberglass pins into the holes of the Units (note: place one pin only per each grouping of three holes). Place pins in the middle hole for near vertical alignment or the holes nearest the embankment for a 9.5° +/- setback per course. According to wall requirements and design, the front pin hole (towards the face of the wall) can be used randomly to allow a forward projection of a specific unit for accent and variation in the wall appearance.

STEP 4:

Install Fill & Compaction.

Once the pins have been installed, provide ½" - ¾" (10 - 20mm) crushed stone drainage fill behind the units to a minimum depth of 12" (300mm). Fill open spaces between units and open cavities/cores with the same drainage material. Proceed to place backfill in maximum 6" (150mm) layers (lifts) and compact to 95% Standard Proctor with the appropriate compaction equipment. Do not use heavy ride-on compaction equipment within 3' (1m) from back of wall. Do not use jumping or ramming type compaction.

STEP 5:

Install Additional Courses.

Place the next course of units over the fiberglass pins, fitting the pins into the long receiving channel recess of the units above (Note: Some removal of debris in the pin holes and channel may be necessary prior to placement). Push the units toward the face of the wall until they make full contact with the pins. If pins do not connect with channel but align in open core of upper unit, place drainage fill in core to provide unit interlock with pin. For near vertical alignment, center the unit above over the center placed pins below.

STEP 6:

Capping the Wall.

Continue all steps until ready to place the wall cap. Clean off the last course in preparation for the cap or coping to finalize the wall. With units dry and clean, use construction adhesive to secure the caps to the units. Install the Stonegate 3" (75mm) capping unit, architectural precast concrete or cut stone as a coping element. Cap may be flush or overhanging as required by aesthetics and design.

NOTES: If drain tile is required for your project, consult an engineer or visit www.keystonehardscapes.com for more information. Colors are shown as accurately as possible in brochures and samples, but due to the nature of the product, regional color differences and variables in print reproduction, colors may not match exactly.

VERSA-LOK® ACCENT® & COBBLE®

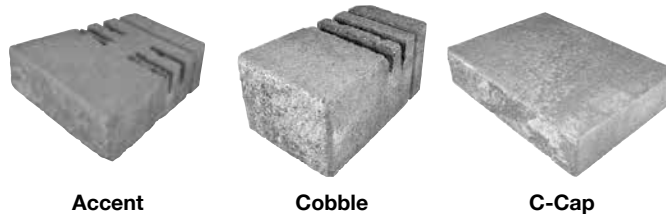

Accent

Cobble

C-Cap

DIMENSIONS

VERSA-LOK ACCENT & COBBLE

Product	Accent	Cobble	C-Cap (Branchville)	C-Cap (Montgomery)
Height (in.)	4	6	3 5/8	3 5/8
Width (in.)	12	8	16	16
Depth (in.)	12	12	12	12
Weight/Unit (lbs.)	37	38	57	57
Sq. Face Ft./Cube	32	30	19.2	18
Units/Cube	96	90	48	45
Weight/Cube (lbs.)	3,550	3,420	2,740	2,569
Part # (Standard)	VAC	VCO	VCC	VCC
Part # (Weathered)	VAC_T	VCO_T	VCC_T	VCC_T

PRODUCT DETAILS

- The VERSA-LOK Accent and Cobble units allow you to create custom eye-catching walls that are perfect for planters, garden beds and smaller retaining walls.

NOTES: Available in standard and weathered finishes. Grid estimating information can be found on: www.versa-lok.com.



Standard Colors								
03 Antique Grey	46 Bedford Brown	09 Brown Flash	36 Butternut	47 Hickory Blend	55 North Creek	24 Pecan Blend	06 Raven Black (C-Cap Only)	05 Red Flash
•	•	•*	•	•	•	•	•	•*

*Limited availability

Design Options Using VERSA-LOK® Accent® & Cobble® Units

Attractive, durable retaining walls can be constructed using only VERSA-LOK Cobble or VERSA-LOK Accent units. These units offer the same features and benefits as VERSA-LOK Mosaic walls, including:

- Classic split-face texture
- Setback or near-vertical walls
- No mortar or concrete footings required
- Great options for tighter radius projects, such as planting areas and tree rings

Maximum height for an unreinforced VERSA-LOK Accent or VERSA-LOK Cobble wall using a ¾" setback is four (4) feet. Maximum height for an unreinforced wall built with a near-vertical setback is three (3) feet. Individual site, soil, and loading conditions (including terraces) may limit unreinforced wall heights to less than those stated. Taller walls require soil reinforcement and engineering assistance. Please contact your local VERSA-LOK representative if unsure about any site, soil, height, or local construction requirements.



VERSA-LOK Accent

- 3' Minimum Outside Radius
- 1 unit = 37 lbs.
- *19 pieces per course will make the tightest circle

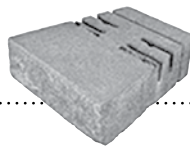

VERSA-LOK Cobble

- 4'4" Minimum Outside Radius
- 1 unit = 38 lbs.
- *21 pieces per course will make the tightest circle

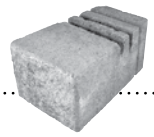

Using VERSA-LOK® Standard and Cobble® Units

1:1 Ratio:

- One Standard block and one Cobble block for each square foot.
- Example: 100 sq./ft. = (1) Standard = 100 pcs.
- (1) Cobble = 100 pcs.

Take the square footage of the project and multiply by the percentages listed on the right. Multiply standard block by 1.5 (like usual) to get quantity of standard blocks. Multiply Cobble block x 3 (3 pcs. per sq. ft.) to get quantity of Cobble blocks.

2:1 Ratio

- Example: 100 sq./ft. = (2) Standard 80% = 80 sq./ft. x 1.5 = 120 pcs.
- (1) Cobble 20% = 20 sq./ft. x 3 = 60 pcs.

3:1 Ratio

- Example: 100 sq./ft. = (3) Standard 85% = 85 sq./ft. x 1.5 = 128 pcs.
- (1) Cobble 15% = 15 sq./ft. x 3 = 45 pcs.

4:1 Ratio

- Example: 100 sq./ft. = (4) Standard 88% = 88 sq./ft. x 1.5 = 132 pcs.
- (1) Cobble 12% = 12 sq./ft. x 3 = 36 pcs.

VERSA-LOK® VERANDA™

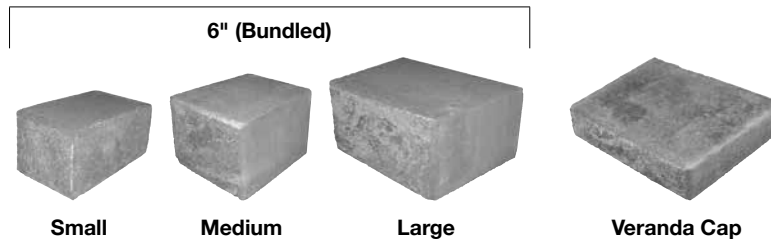

DIMENSIONS

VERSA-LOK VERANDA	6" (Bundled)				
Product	Small	Medium	Large	6" Large Only	Veranda Cap
Height (in.)	6	6	6	6	3
Width (in.)	5-4	8-7	13-11	13-11	14-12
Depth (in.)	9 ¾	9 ¾	9 ¾	9 ¾	12
Weight/Unit (lbs.)	21 approx.	38 approx.	56 approx.	56 approx.	35 approx.
Sq. Face Ft./Cube	40			30	44.16 Lin. ft.
Units/Cube	40	40	40	60	48
Weight/Cube (lbs.)	4,310			3,350	1,680
Part # (Standard)	VWK			VWL	VWC
Part # (Weathered)	VWK_T			VWL_T	VWC_T

PRODUCT DETAILS

- Units can be placed forward, backward, right side up, or upside down.
- Units will require adhesive.

NOTES: Available in standard and weathered finishes.



Standard Colors								
03 Antique Grey	46 Bedford Brown	09 Brown Flash	36 Butternut Special Order	47 Hickory Blend	55 North Creek	24 Pecan Blend	06 Raven Black	05 Red Flash

Building Veranda Corners

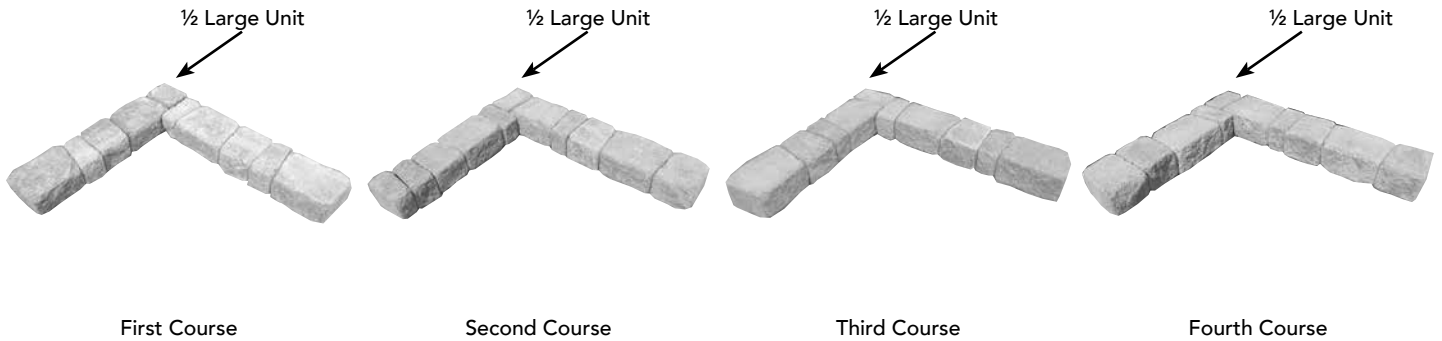

With the Veranda Combo Kits, 90-degree corners can be made with just a few splits. We recommend using 1 Large unit split in half for your corner pieces. From the corner, continue on using a running bond. Alternate the first unit coming off the corner on each course to break up the pattern. Veranda units do not have split lines, so a hydra-splitter will be necessary. A masonry hammer field dressing may also be necessary to achieve the weathered look.

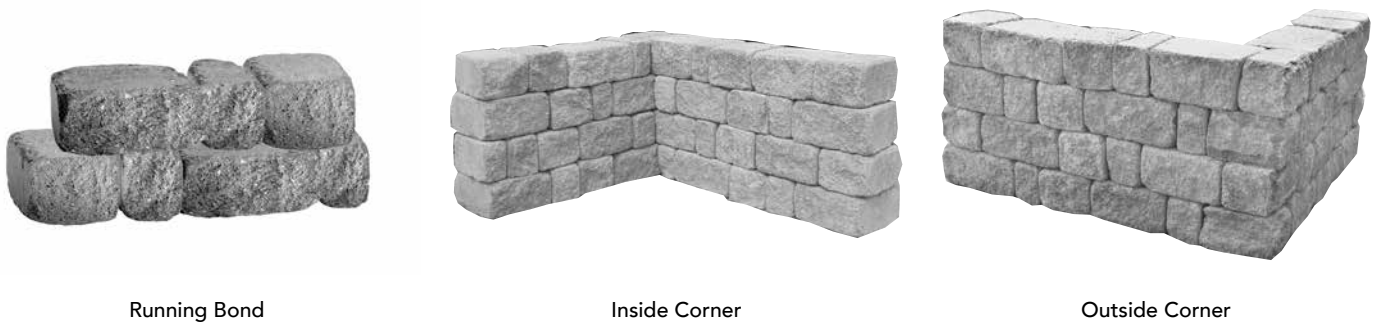

Veranda Cap Unit

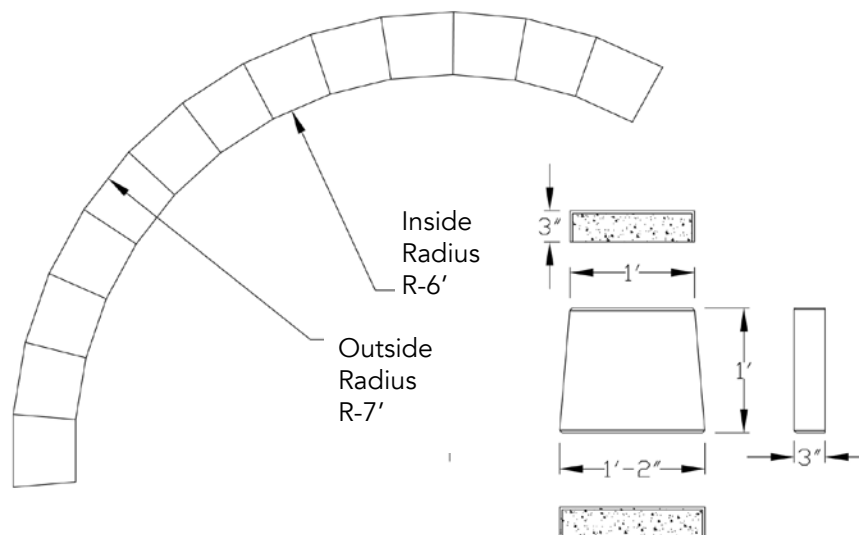

MUNICH™ WALL FIRE PIT KIT

DIMENSIONS

MUNICH WALL FIRE PIT KIT	
Height (in.)	16
Inside Diameter (in.)	30
Outside Diameter (in.)	46
Weight (lbs.)	1,288
Part #	FPC



PRODUCT DETAILS

- The fire pit kit makes a 46" outside dimension and a 30" inside dimension. The kit comes with 72 pieces of Munich Wall Small Radius and each row requires 18 pieces.
- Fire Pit Kits Include:
 - Fire pit ring: Part #FPR
 - Spark screen: Part #FPS
 - Lifter/poker: Part #FPP
- Sold Separately:
 - Removable grill: Part #FPR
 - Vinyl grill cover: Part #FPS
 - Fire pit caps: Part #FPP

NOTE: Available in weathered finish only.

Standard Colors								
03 Antique Grey	46 Bedford Brown	09 Brown Flash	36 Butternut	47 Hickory Blend	55 North Creek	24 Pecan Blend	06 Raven Black	05 Red Flash
•	•		•	•				

WARNING: Combustion byproducts produced when using this product include carbon monoxide, a chemical known to the State of California to cause birth defects or other reproductive harm.



FREQUENTLY ASKED WALL QUESTIONS

Why is it so difficult to get my VERSA-LOK Pins to go into the block?

If you find the pinning to be extremely difficult, the odds are that you have installed the block upside down. The slots and pin holes have to be facing up.

What is efflorescence?

Efflorescence is a whitish powder-like deposit which sometimes appears on concrete and clay products. The deposit is the residue of a soluble salt (inherent in concrete products) carried to the face of the product by moisture and left on the surface as a dried white powder. Efflorescence is completely natural and will disappear with time.

Do retaining walls require concrete footings below the frost line?

No. Keystone Hardscapes retaining walls are installed on shallow, non-rigid leveling pads consisting of well compacted gravel, crushed stone or coarse sand. The flexible nature of the walls allows them to accommodate minor earth movement without damage.

How tall can walls be built?

Generally, walls can be built to any height. The maximum unreinforced wall height varies depending on site conditions, but does not exceed four (4) feet. Taller walls require soil reinforcement designed by a qualified engineer.

What maintenance do walls require?

None. Once constructed, Keystone Hardscapes retaining walls provide a lifetime of virtually maintenance-free performance. Color is consistent throughout the units, so natural wear-and-tear is not apparent.

How do I determine grid lengths needed for my wall?

You can use the charts within this book or on our website: www.keystonehardscapes.com. Contact your local authorized Keystone Hardscapes distributor for help or call Keystone Hardscapes directly at 1 (888) 275-4278, and we can do a preliminary drawing for your wall application to show you the grid lengths. Depending on local codes you may need stamped plans/drawings.

Do I need to add drainage to my wall?

Yes! The number one cause for wall failure is hydrostatic pressure caused by water build up. You will always need to use ¾" clean stone and drainage pipes to insure proper drainage of your retaining wall.

Wall Accessories



Quikrete Adhesive
#990210



SRW Grid
5 Series - #GSRW5615
7 Series - #GSRW7615



Versa-Lifter®
#VLIFT01



Square Foot Versa-Lifter®
#SFLIFT1C



Keystone Key Lifter
#995-000206



Keystone Simple Set
995-000205



Versa-Pins
Bag: #PINB1B



Versa-Snap-Off Pins
Bag: #SPINB1B



Keystone Straight Pins
Box of 100: #995-000224



Keystone Shouldered Pins
Box of 100: #995-000160

VERSA-LOK® STANDARD ESTIMATING WORKSHEET

These are the calculations for VERSA-LOK® Standard Units.

Note: Grid estimating information can be found on: www.versa-lok.com.

VERSA-LOK® Units

Formula: Area of wall (sq. ft.) x 1.5 units per sq. ft. = Number of units

_____ sq. ft. x 1.5 = _____ Units needed

VERSA-LOK® Pins

NOTE: Pins will not be used on the base course.

Formula: Units x 2 pins per unit = Number of pins

_____ units x 2 = _____ Pins needed

VERSA-LOK® Caps

Additional caps may be needed for special splits or cuts.

Formula: Linear feet of wall (LF) x 0.75 = Number of C Caps

_____ linear feet x 0.75 = _____ C caps needed

Quikrete® Construction Adhesive

Formula: 10.1 oz. tube: Linear feet of wall (LF) ÷ 12 LF per tube = Number of tubes (Recommended two ¼" beads)

_____ linear feet ÷ 12 LF per tube = _____ Tubes needed

Geogrid and Geosynthetic Materials

For estimating purposes, use the grid tables. They provide approximate amounts of grid soil reinforcement needed to construct walls in certain soil and loading conditions. For tall walls or complex situations, VERSA-LOK engineers can prepare specific preliminary designs to be used for estimation purposes.

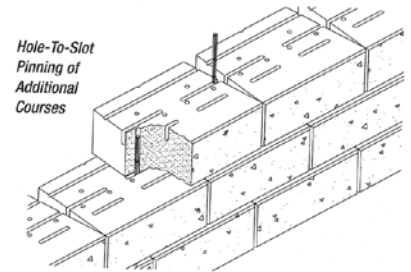

GEOGRID & GEOSYNTHETIC MATERIALS

Grid	1.5	3.0	5.0
Length (Lin. Ft.)	50	150	150
Width (Ft.)	4	6	6
Total Sq. Yardage	22.22	100	100

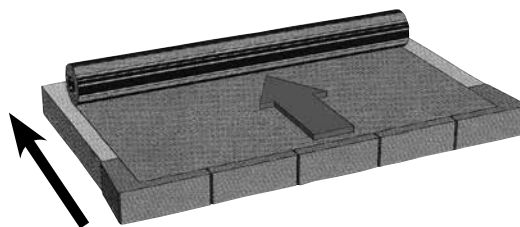
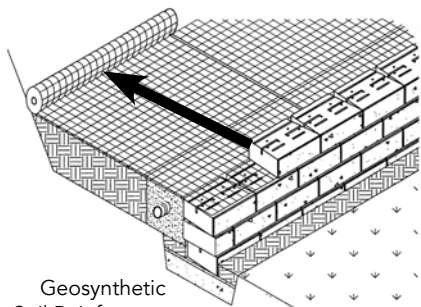

The maximum unreinforced wall height varies depending on site conditions, but does not exceed four feet. Taller walls require soil reinforcement designed by a qualified engineer.

Properly designed, grid reinforced walls may be economically constructed to heights exceeding 40 feet.

IMPORTANT! Grid must be unrolled and installed perpendicular to the retaining wall face. Failure to install in this direction may result in structurally unsafe wall conditions. If unsure about any wall construction procedures, please contact Keystone Hardscapes or VERSA-LOK at 1 (800) 770-4525.

VERSA-LOK® MATERIAL ESTIMATING WORKSHEET

For estimating purposes, use the grid tables. They provide approximate amounts of grid soil reinforcement needed to construct walls in certain soil and loading conditions. For tall walls or complex situations, VERSA-LOK staff engineers can prepare project specific preliminary designs to be used for estimation purposes.

Note: Grid estimating information can be found on: www.versa-lok.com.

VERSA-LOK® Standard (Embedded Units for Burial) N - first course

Formula: Linear feet of wall (LF) x 0.75 units per LF = Number of Standard units for base

$$\underline{\hspace{2cm}} \text{ LF } \times 0.75 = \underline{\hspace{2cm}} \text{ Units needed for 1st course}$$

VERSA-LOK® Standard

Formula: Area of wall (sq. ft.) ÷ 1.66 units per sq. ft. = Number of Standard units

$$\underline{\hspace{2cm}} \text{ sq. ft. } \div 1.66 = \underline{\hspace{2cm}} \text{ Units needed**}$$

VERSA-LOK® Cobble®

Formula: Area of wall (sq. ft.) ÷ 1.66 units per sq. ft. = Number of Cobble units

$$\underline{\hspace{2cm}} \text{ sq. ft. } \div 1.66 = \underline{\hspace{2cm}} \text{ Units needed**}$$

VERSA-LOK® Accent®

Formula: Area of wall (sq. ft.) ÷ 1.66 x 2 units per sq. ft. = Number of Accent units

$$\underline{\hspace{2cm}} \text{ sq. ft. } \div 1.66 \times 2 = \underline{\hspace{2cm}} \text{ Units needed**}$$

VERSA-LOK® Snap-Off Pins

NOTE: Base course of VERSA-LOK Standard Units does not require pins.

Formula: Area of wall (sq. ft.) ÷ 1.66 x 8 = Number of pins

$$\underline{\hspace{2cm}} \text{ sq. ft. } \div 1.66 \times 8 = \underline{\hspace{2cm}} \text{ Pins needed}$$

VERSA-LOK® Caps

Additional caps may be needed for special splits or cuts.

Formula: Linear feet of wall (LF) x 0.75 = Number of C Caps

$$\underline{\hspace{2cm}} \text{ LF } \times 0.75 = \underline{\hspace{2cm}} \text{ C Caps needed}$$

Quikrete® Construction Adhesive

Based on two ¼" beads.

Formula: Linear feet of wall (LF) ÷ 6 LF per Tube = Number of tubes

$$\underline{\hspace{2cm}} \text{ LF } \div 6 \text{ LF} = \underline{\hspace{2cm}} \text{ Tubes needed}$$

** This quantity does not include estimates for embedded or buried units (shown above). The quantity of buried units (generally all Standard units) should be added to this number.

VERSA-LOK® MOSAIC® UNIT SPECIFICATIONS

All slots should be facing UP when constructing a VERSA-LOK wall.

Note: Grid estimating information can be found on: www.versa-lok.com.

Mosaic® Panel Configurations

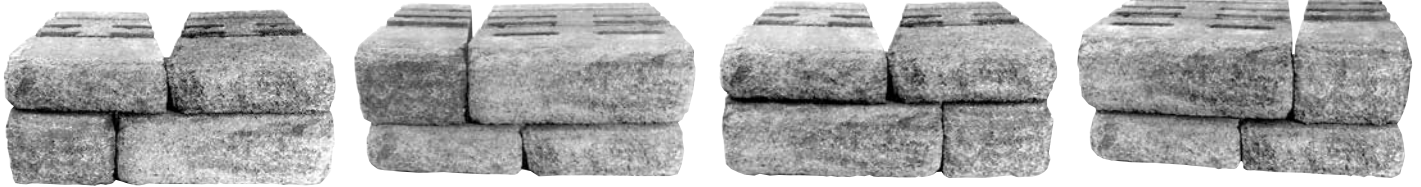

(Actual unit size and weight may vary slightly by region.)

MOSAIC

Product	Standard	Cobble	Accent
Height (in.)	6	6	4
Width (face) (in.)	16	8	12
Width (rear) (in.)	14	6	8
Depth (in.)	12	12	12
Face Area	½ foot ²	⅓ foot ²	⅓ foot ²
Weight (lbs.)	82	38	37
Weight/Face Area	123 lbs./foot ²	111 lbs./foot ²	108 lbs./foot ²

Each Mosaic panel is 1.66 square feet in wall-face area. For each panel, there is one Standard unit, two Accent units, and one Cobble unit. The following formulas and table may be used to estimate quantities of units required for a Mosaic retaining wall project. Mosaic is available in Standard and Weathered finishes.



Standard

No. of Standard Units =
Wall Sq. Footage ÷ 1.66



Accent®

No. of Accent Units =
Wall Sq. Footage ÷ 1.66 x 2



Cobble®

No. of Cobble Units =
Wall Sq. Footage ÷ 1.66

VERSA-LOK® Mosaic Quantity Estimation Chart

EXPOSED WALL HEIGHT	EXPOSED WALL LENGTH	10 FT.	12 FT.	14 FT.	16 FT.	18 FT.	20 FT.	22 FT.	24 FT.	26 FT.	28 FT.	30 FT.
10"	Standard	5	6	7	8	9	10	11	12	13	14	15
	Cobble	5	6	7	8	9	10	11	12	13	14	15
	Accent	10	12	14	16	18	20	22	24	26	28	30
20"	Standard	10	12	14	16	18	20	22	24	26	28	30
	Cobble	10	12	14	16	18	20	22	24	26	28	30
	Accent	20	24	28	32	36	40	44	48	52	56	60
30"	Standard	15	18	21	24	27	30	33	36	39	42	45
	Cobble	15	18	21	24	27	30	33	36	39	42	45
	Accent	30	36	42	48	54	60	66	72	78	84	90
40"	Standard	20	24	28	32	36	40	44	48	52	56	60
	Cobble	20	24	28	32	36	40	44	48	52	56	60
	Accent	40	48	56	64	72	80	88	96	104	112	120

*This chart does not include estimates for embedded (buried) units. Each panel requires 8 Snap-Off Pins. The quantity of embedded units, (generally Standard units) should be added to the above numbers.

COLUMN CONSTRUCTION IDEAS

Munich Wall 20" Column

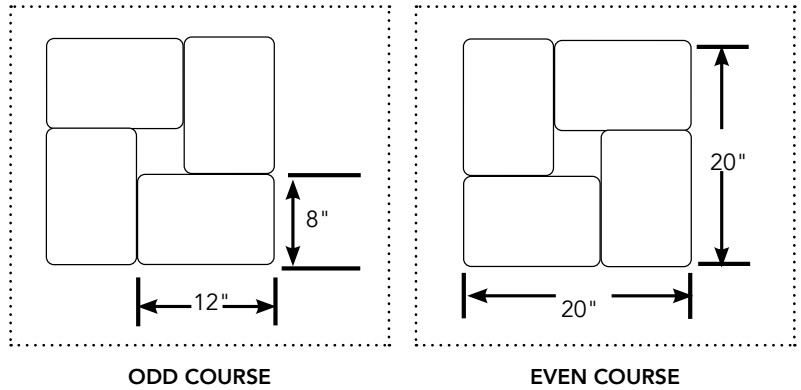

Installation Sequence - Unreinforced Column (6' Tall Max.)

Each course is built with four (4) Munich wall units.

- Each odd course is built with four Munich wall units.
- Even and odd courses are built with the same alternating placement of blocks.

Column notes:

- Units will not pin.
- Adhere units together using concrete adhesive.

MUNICH WALL 20" COLUMN	
Column Size (in.)	20
Pieces/Each Course	4 units
Pieces Needed - 3 Ft. Tall	4 units
Pieces Needed - 3 Ft. Tall	36 units
Pieces Needed - 4 Ft. Tall	44 units



COLUMN CONSTRUCTION IDEAS

24" Full Corner Column

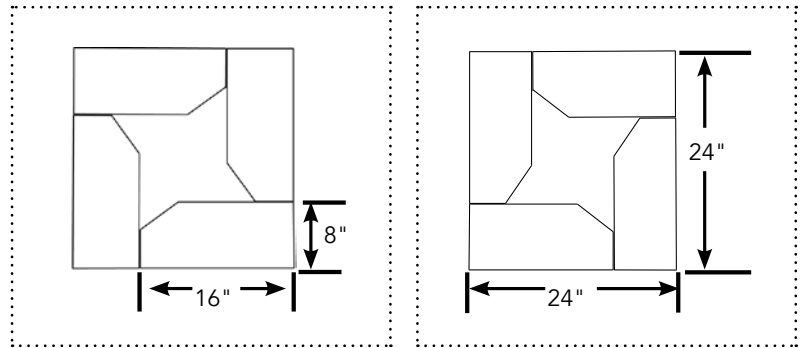

ODD COURSE

EVEN COURSE

Installation Sequence - Unreinforced Column (6' Tall Max.)

Each course is built with four (4) full-size corner units.

- Each odd course is built with four full-size corner units.
- Even and odd courses are built the same alternating placement of blocks.

Column notes:

- Units will not pin.
- Adhere units together using concrete adhesive.

24" FULL CORNER COLUMN

Column Size (in.)	24
Pieces/Each Course	4 units
Pieces Needed - 3 Ft. Tall	4 units
Pieces Needed - 3 Ft. Tall	24 units
Pieces Needed - 4 Ft. Tall	24 units

VERSA-LOK® Square Foot 27" Corner Column

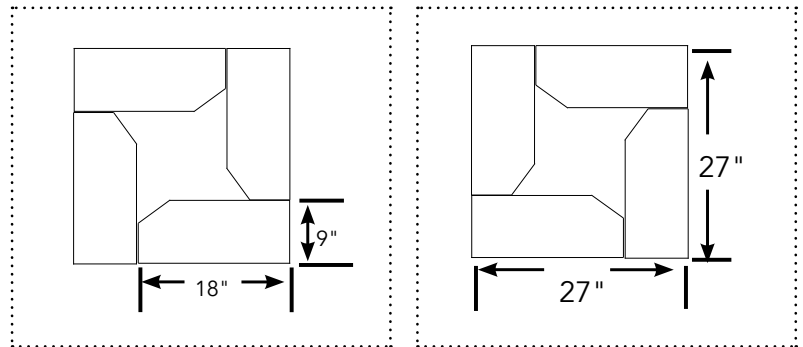

ODD COURSE

EVEN COURSE

Installation Sequence - Unreinforced Column (6' Tall Max.)

Each course is built with four (4) Square Foot corner units.

- Each odd course is built with four Square Foot corner units.
- Even and odd courses are built the same alternating placement of blocks.

Column notes:

- Units will not pin.
- Adhere units together using concrete adhesive.

VERSA-LOK SQUARE FOOT 27" CORNER COLUMN

Column Size (in.)	27
Pieces/Each Course	4 units
Pieces Needed - 3 Ft. Tall	4 units
Pieces Needed - 3 Ft. Tall	20 units
Pieces Needed - 4 Ft. Tall	24 units

STONE CAPS, TREADS & STEPS

PIER CAPS - Wet Cast



Light Cap



Peak Cap



Flat Cap

LIGHT CAPS				
Size	22x22	26x26	30x30	32x32
Pieces/Pallet	6	6	6	6
Weight/Piece (lbs.)	135	180	240	250
Est. Ship Weight/Pallet (lbs.)	810	1,080	1,440	1,500
Part #	PCLT	PCLTS	PCLTM	PCLTL

PEAK CAPS				
Size	22x22	26x26	30x30	32x32
Pieces/Pallet	6	6	6	6
Weight/Piece (lbs.)	145	190	275	280
Est. Ship Weight/Pallet (lbs.)	870	1,140	1,650	1,680
Part #	PC	PCS	PCM	PCL

FLAT CAPS					
Size	22x22	26x26	30x30	32x32	36x36
Pieces/Pallet	12	12	12	12	12
Weight/Piece (lbs.)	95	130	155	180	240
Est. Ship Weight/Pallet (lbs.)	1,140	1,560	1,860	2,160	2,880
Part #	PCF	PCFS	PCFM	PCFL	PCFX

Standard Colors	
07 Cocoa Brown	03 Grey
●	●

NATURAL STONE



Full pallets only.

CAPS		
Size	22x22x2	26x26x2
Weight/Piece (lbs.)	97.5	131
Pieces/Cube	13	13
Weight/Cube (lbs.)	1,267	1,706
Part #	YV22222	YV26262

TREADS				
Size	12x48x2	14x48x2	12x72x2	14x72x2
Weight/Piece (lbs.)	116	135	174	203
Pieces/Cube	24	24	12	12
Weight/Cube (lbs.)	2,784	3,248	2,088	2,436
Part #	YV21248	YV21448	YV21272	YV21472

LANDSCAPE STEPS		
Size	16x48x6	16x72x6
Weight/Piece (lbs.)	464	696
Pieces/Cube	8	4
Weight/Cube (lbs.)	3,712	4,176
Part #	YV61648	YV61672

Landscape Steps
(Special Order - please call for availability and pricing.)

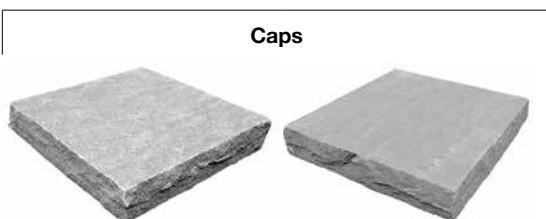

Caps



Tread



Landscape Step

Standard Colors	
* Chateau Limestone	Black Sandstone
●	●

*Just add a 9 to the end of product code for Chateau Limestone.

STONE CAPS, TREADS & STEPS

LANDSCAPE STEPS - Wet Cast

LANDSCAPE STEPS			
Size	6x16x36	6x16x48	6x16x72*
Part #	LLS+color	LSM+color	LS+color

Landscape Steps
*Special Order Only.



Standard Colors	
07 Cocoa Brown	03 Grey
●	●

NOTES: Do not apply salts and/or other de-icing products. Do not use efflorescence cleaners. Blended colors will provide variations from light to dark.

QUIKRETE and its subsidiaries (collectively QUIKRETE) reserve the right to improve its products and make changes to its specification and design without notice. The information contained herein has been compiled by QUIKRETE and to the best of its knowledge, accurately represents Keystone Hardscapes products and how they may be used in the applications which are illustrated. Site conditions, including load pressures acting on the wall, soil types and drainage conditions, may vary. Final determination of the suitability of the product for the use contemplated and the manner of product use are the sole responsibility of the user. Good construction practices and local building codes require the use of an engineered design when constructing retaining walls or freestanding walls in many conditions. Structural design and analysis should be provided by a qualified engineer.

NOTICE OF LIMITED WARRANTY:

The terms of the Limited Warranty applicable to our products can be found at www.keystonehardscapes.com or can be obtained by sending a written request to c/o Keystone Hardscapes, 5 Concourse Parkway, Atlanta, USA.



BRANCHVILLE, NJ
23 Ridge Road
Branchville, NJ 07826
973-948-7193

MONTGOMERY, NY
43 Leonards Drive
Montgomery, NY 12549
845-457-4491

www.keystonehardscapes.com

© 2020 The QUIKRETE Companies - Patents Pending • KHS - 05/2020