

MODEL PL-39000-30

Filter Cartridges: (30) EX-14D52-B16-SF

Media Area: 15,360 sq. ft.

Dimensions: 98" D x 147" W x 97" H
(motor adds between 15" - 28")

Weight: 12,940-13,970 lbs.*

Equipment:

eTell™ Intelligent Controls: Forget about your dust collectors. They'll let you know when they need something. They are predictive, cloud-based, and smart.

SafeSensor™: Particulate Monitoring Device

Endurex™ B16 Media: Merv 16 PTFE membrane laminated to polyester spunbound substrate. RMO technology to provide maximum efficiency and particulate release.

High Performance Acoustical Silencing

Heavy Duty Construction: Fully welded 11 gauge steel

Dynamic Pulsing System:

Patent Pending, double-pulse filter cleaning system

Offline Pulse – 36.72 SCFM**

Online (Dynamic Pulse) – 19.05 SCFM***

Vertical Filter Design

Extra Deep Dust Drawer

Nema 4X Super Seal Doors and Control Panel Enclosure

UL Listed Controls

Complete Packaged Product

Warranty: 15 years on the cabinet; 5 years on components
(See warranty document for details)

Configuration Options:

Hopper & Short Legs w/ 20 Gallon Drum adds 61" to height

Hopper & Long Legs w/ 55 Gallon Drum
adds 80" to height (Recommended for heavy loading applications)

Rotary Air Lock adds 92" to height

Chimney Silencer adds 30" to height

Full top Silencer adds 51" to height

Options:

Delta3™ SparkOut Spark Arrestor

Supprex-200™: A completely engineered fire suppression system activated by heat, creating a safer work environment

eDrive™: Automatically adjust the airflow via a flow monitor and VFD to extend filter life and reduce energy cost by up to 30%

AutoSaver™: The Auto On/Off feature that reduces energy costs by running the filtration system ONLY when the cutting system is turned on

Voltage Upgrades: 208, 230 or 575 Volts

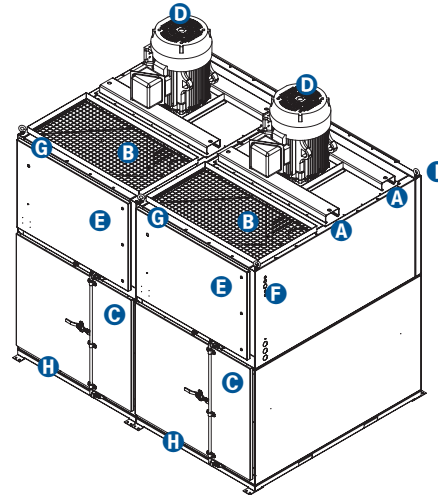

- A** Fork Pockets
- B** Clean Air Exhaust
- C** Filter Access Door
- D** Motor

- E** Electrical Enclosure
- F** Compressed Air & Solenoid Access
- G** Compressed Air Connection 1" NPT

- H** Dust Tray
(inside Filter Access Door)
- I** Blower Access (on back)

Motor/Blower Configuration	CFM@IN S.P.	Air to Cloth Ratio	F.L. Amps @ 480V
(2) 15 HP 24 @ 30%	10000 @ 10	0.7:1	2 x 21.0
(2) 15 HP 24 @ 30%	8500 @ 15	0.6:1	2 x 21.0
(2) 25 HP 30 @ 32%	17500 @ 10	1.1:1	2 x 34.0
(2) 25 HP 30 @ 32%	15100 @ 15	1.0:1	2 x 34.0
(2) 30 HP 36 @ 35%	25100 @ 10	1.6:1	2 x 40.0
(2) 40 HP 36 @ 35%	23700 @ 15	1.5:1	2 x 52.0
(2) 50 HP 36 @ 35%	30800 @ 10	2.0:1	2 x 65.0
(2) 50 HP 36 @ 51%	31500 @ 15	2.1:1	2 x 65.0

* Weight does NOT include Intakes or any custom options that may be added. For project specific weights, contact the Engineering department.

** Every time the blower turns off: 15 cycles x 10 filters x 10 second intervals = 25 minutes at 12.24 SCFM

*** When the Online Pulse Threshold (typically 1kpa Filter DP) is exceeded: 6.35 SCFM until DP drops below Threshold. The amount of time over the Threshold (Online Pulsing active) is dependent on specific application filter loading.