



# 432 DUAL STAGE STAINLESS STEEL REGULATOR

The 432 Series regulators are intended for primary pressure control of ultra-high purity or corrosive gases for applications requiring constant pressure control and delivery regardless of supply pressure variations.

## Highlighted Features

- Dual Stage
- 316L Stainless Steel Barstock Body
- Six Port Configuration
- 316L Stainless Steel Diaphragm

## Typical Applications

- ❖ EPA protocol gases
- ❖ Gas and liquid chromatography
- ❖ High purity carrier gases
- ❖ Zero, span, and calibration gases
- ❖ Ultra-high purity chamber pressurization
- ❖ Liquefied hydrocarbon gas control
- ❖ Corrosive gases



432 REGULATOR  
WITH DIAPHRAGM VALVE  
SHOWN HERE

Features	Materials	Specifications
<p><b>Metal-to-Metal Diaphragm Seal</b> No possibility of gas contamination</p> <p><b>CAPSULE® Seat</b> Increased serviceability and life</p> <p><b>316L Stainless Steel Barstock Body</b> Increased corrosion resistance</p> <p><b>Front Panel-Mountable</b> Easy installation</p> <p><b>10 Micron Filtration in Both Stages</b> Fail-safe seat performance</p> <p><b>Pressure Ranges 0-15 to 0-350 PSIG (0-1 BAR to 0-24 BAR)</b> Broad range of applications</p> <p><b>Pipe Away Relief Valve</b> Safely vents exhaust gases</p>	<p><b>Body</b> 316L stainless steel barstock</p> <p><b>Bonnet</b> Chrome-plated brass barstock</p> <p><b>Seat</b> PCTFE (first stage) PTFE (second stage)</p> <p><b>Filter</b> Patented 10 micron 316 mesh</p> <p><b>Diaphragm</b> 316L stainless steel</p> <p><b>Internal Seals</b> PPTFE</p>	<p><b>Maximum Inlet Pressure</b> 3000 PSIG (210 BAR) 3500 PSIG (240 BAR) optional 4500 PSIG (310 BAR) optional</p> <p><b>Temperature Range</b> -40°F to 140°F (-40°C to 60°C)</p> <p><b>Gauges</b> 2" (53mm) diameter stainless steel</p> <p><b>Ports</b> 1/4" FPT</p> <p><b>Helium Leak Integrity</b> 1 x 10<sup>-9</sup> scc/sec</p> <p><b>Cv</b> 0.1 <i>Refer to flow curve chart below</i></p> <p><b>Weight (432 3331-580)</b> 5.09 lbs. (2.31 kg)</p>

# Order Information

Model	A	B	C	D	-CON	Installed Options	
Series	Outlet Pressure	Outlet Gauge	Inlet Gauge	Outlet Assemblies	Gauges	Inlet Connections	Installed Options
<b>432</b>	<b>1:</b> 0-15 PSIG (0-1 BAR) <sup>1</sup>	30"-0-30 PSIG/ -1-0-2 BAR	<b>0:</b> None	<b>0:</b> 1/4" FPT port	<b>0:</b> Bare body	<b>000:</b> 1/4" FPT	<b>B:</b> Protocol alarm station with pressure switch gauges
	<b>2:</b> 0-50 PSIG (0-3.5 BAR)	30"-0-100 PSIG/ -1-0-7 BAR	<b>3:</b> 0-4000 PSIG/ 0-310 BAR	<b>1:</b> 1/4" MPT	<b>1:</b> Cleanroom assembly (PSIG/kPa gauges)	<b>TF2:</b> 1/8" tube	<b>C:</b> Protocol switchover station
	<b>3:</b> 0-100 PSIG (0-7 BAR)	30"-0-200 PSIG/ - 1-0-14 BAR	<b>5:</b> 0-1000 PSIG/ 0-70 BAR	<b>2:</b> 1/4" tube fitting	<b>2:</b> Cleanroom assembly (BAR/PSIG gauges)	<b>TF4:</b> 1/4" tube	<b>D:</b> Deep purge <sup>1</sup>
	<b>4:</b> 0-250 PSIG (0-17 BAR)	0-400 PSIG/ 0-27 BAR	<b>6:</b> 0-300 PSIG/ 0-21 BAR	<b>3:</b> Diaphragm valve 1/4" tube fitting		<b>TF6:</b> 3/8" tube	<b>E:</b> Protocol alarm station with intrinsically safe transducer for hazardous environments
	<b>7:</b> 0-150 PSIG (0-10 BAR)	0-1000 PSIG/ 0-70 BAR	<b>7:</b> 0-400 PSIG/ 0-27 BAR	<b>4:</b> Diaphragm valve 1/4" MPT		<b>M06:</b> 6mm	<b>H:</b> Protocol switchover alarm station with pressure switch gauges
		30"-0-200 PSIG/ -1-0-14 BAR	<b>8:</b> 0-6000 PSIG* / 0-400 BAR	<b>5:</b> Needle valve 1/4" MPT <b>6:</b> 1/8" tube fitting <b>7:</b> 3/8" tube fitting		CGA DIN 477 BS 341 and others available	<b>J:</b> Protocol alarm station with standard transducer for non-hazardous environments
			<b>G:</b> 0-4000 PSIG/ 0-275 BAR †	<b>8:</b> Diaphragm valve 1/8" tube fitting			<b>K:</b> Protocol switchover alarm station with standard transducer for non- hazardous environments
				<b>9:</b> Diaphragm valve 1/4" FPT			<b>M:</b> Protocol station <b>Q:</b> Protocol purge station <sup>1</sup> <b>S:</b> Stainless steel bonnet
				<b>M:</b> 6mm tube fitting <b>S:</b> Diaphragm valve 6mm tube fitting			<b>X:</b> Protocol switchover alarm station with intrinsically safe transducer for hazardous environments

**Notes:**

- <sup>1</sup> Not available with 4500 PSIG (310 BAR) maximum inlet pressure
- <sup>2</sup> Standard assembly does not include relief valve
- \*Maximum inlet pressure 4500 PSIG (310 BAR) with PCTFE seat CAPSULE®
- †Maximum inlet pressure 3500 PSIG (240 BAR) with PCTFE seat CAPSULE®

## Related Options

Part Number	Description
CON 550-0002	Panel mount kit
CON 550-0001	Captured vent kit
CON 476-0002	Helium leak certification

## Installation Dimensions

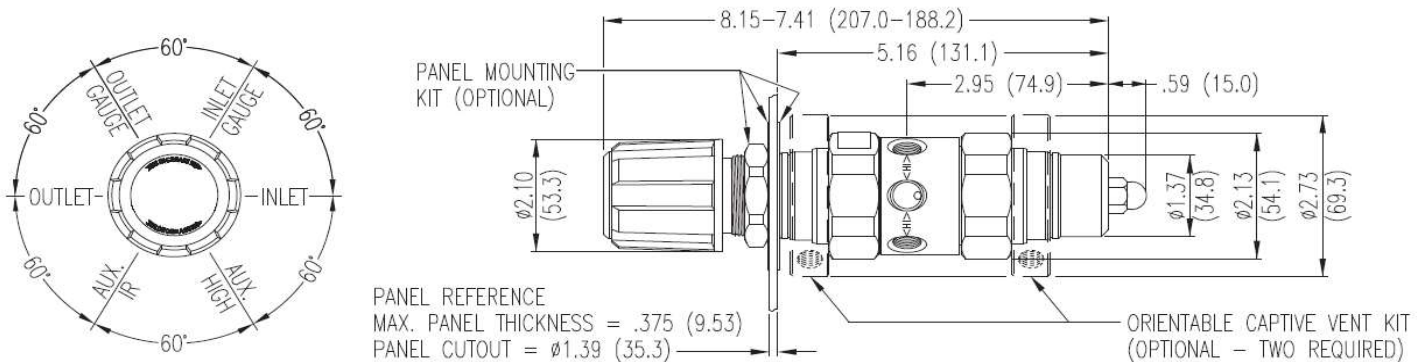

## 432 Regulator Flow Curves

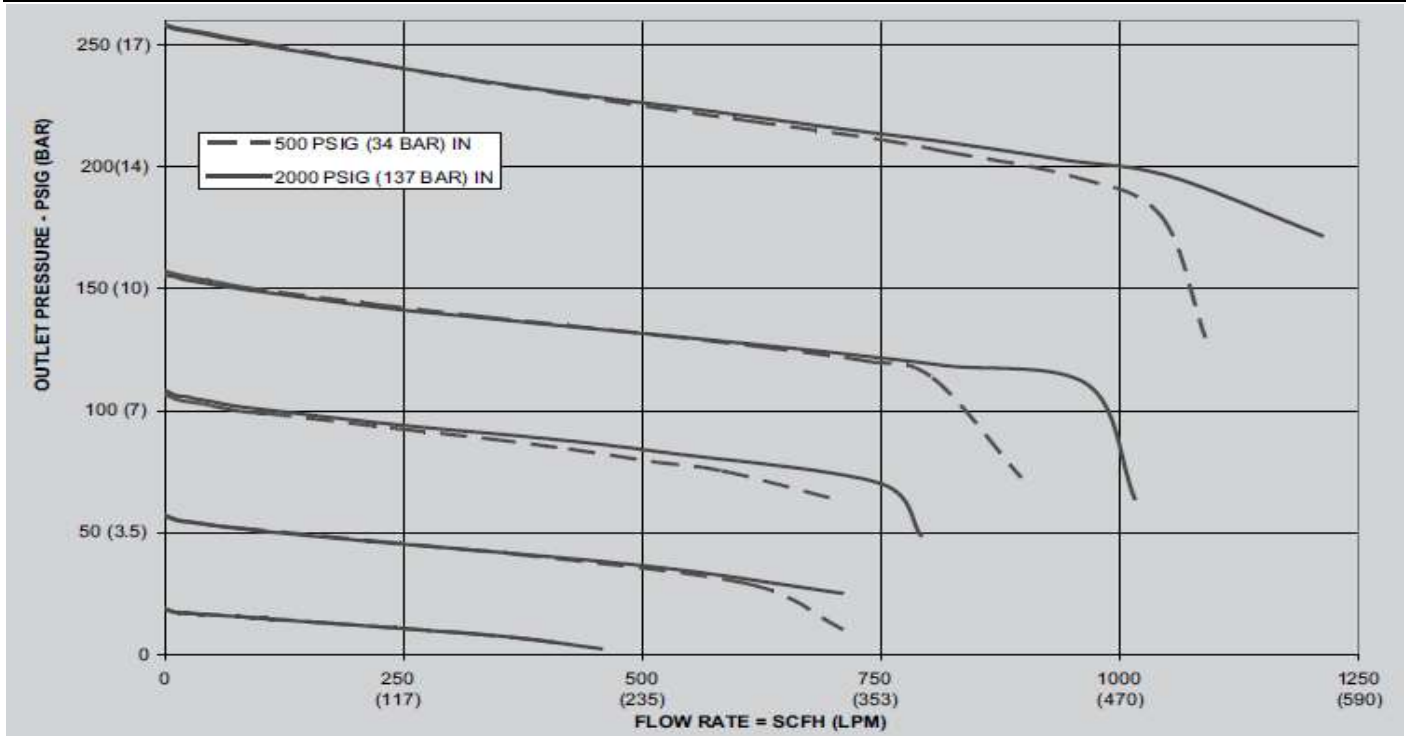

*Can't find what you need? We will be happy to assist you to find the right regulator to fit your needs.*