



# 312 DUAL STAGE CHROME BRASS EPA PROTOCOL REGULATOR

The 312 Series regulators are intended for primary pressure control of non-corrosive, high purity or liquefied gases for applications requiring constant pressure control and delivery regardless of supply pressure variations.

## Highlighted Features

- Dual Stage
- Chrome-Plated Brass Barstock Body
- Four Port Configuration
- 316L Stainless Steel Diaphragm

## Typical Applications

- ❖ EPA Protocol gases
- ❖ Gas and liquid chromatography
- ❖ High purity carrier gases
- ❖ Zero, span, and calibration gases
- ❖ High purity chamber pressurization



Features	Materials	Specifications
<p><b>CAPSULE® Seat</b> Increased serviceability and life</p> <p><b>316L Stainless Steel Diaphragm</b> No inboard diffusion</p> <p><b>Low Wetted Surface Area</b> Minimal purge requirements</p> <p><b>Field-Adjustable Pressure Limit</b> Safeguard downstream equipment</p> <p><b>Convolute Diaphragm</b> Smooth pressure changes</p> <p><b>Compact Design</b> Easily transported and integrated into systems</p> <p><b>Chrome-Plated Brass Barstock Body</b> Smooth surface finish</p> <p><b>10 Micron Filtration in Both Stages</b> Fail-safe seat performance</p> <p><b>Pressure Ranges 0-15 to 0-250 PSIG (0-1 to 0-17 BAR)</b> Broad range of applications</p>	<p><b>Body</b> Chrome-plated brass barstock</p> <p><b>Bonnet</b> Chrome-plated die-cast zinc</p> <p><b>Seats</b> PCTFE (first stage) PTFE (second stage)</p> <p><b>Filter</b> 10 micron sintered bronze</p> <p><b>Diaphragm</b> 316L stainless steel</p> <p><b>Internal Seals</b> PTFE</p>	<p><b>Maximum Inlet Pressure</b> 3000 PSIG (210 BAR) 3500 PSIG (240 BAR) optional 4500 PSIG (310 BAR) optional</p> <p><b>Temperature R</b> -40°F to 140°F (-40°C to 60°C)</p> <p><b>Gauge</b> 2" (53mm) diameter chrome-plated brass</p> <p><b>Ports</b> 1/4" FPT</p> <p><b>Helium Leak Integrity</b> 1 x 10<sup>-9</sup> scc/sec</p> <p><b>Cv</b> 0.1 <i>Flow curves on pages to follow</i></p> <p><b>Weight (414 2331-580)</b> 5.3 lbs. (2.40 kg)</p>

## Order Information

Model	A	B	C	D	-CON	Options	
Series	Outlet Pressure	Outlet Gauge	Inlet Gauge	Outlet Assemblies	Assembly Gauges	Inlet Connections	Installed Options
312	1: 0-15 PSIG (0-1 BAR)	30"-0-30 PSIG/ -1-0-2 BAR	0: None	0: 1/4" FPT port 1: 1/4" MPT	0: Bare body	000: 1/4" FPT	B: Protocol alarm station with pressure switch gauges
	2: 0-50 PSIG (0-3.5 BAR)	30"-0-100 PSIG/ -1-0-7 BAR	3: 0-4000 PSIG/ 0-275 BAR	2: 1/4" tube fitting 3: Diaphragm valve 1/4" tube fitting	1: Cleanroom assembly (PSIG/kPa gauges)	TF2: 1/8" tube	C: Protocol switchover station
	3: 0-100 PSIG (0-7 BAR)	30"-0-200 PSIG/ -1-0-14 BAR	5: 0-1000 PSIG/ 0-70 BAR	4: Diaphragm valve 1/4" MPT 5: Needle valve 1/4" MPT	2: Cleanroom assembly (BAR/PSIG gauges)	TF4: 1/4" tube	E: Protocol alarm station with intrinsically safe transducer for hazardous environments
	4: 0-250 PSIG (0-17 BAR)	0-400 PSIG/ 0-27 BAR	6: 0-300 PSIG/ 0-21 BAR	6: 1/8" tube fitting 7: 3/8" tube fitting		TF6: 3/8" tube	H: Protocol switchover alarm station with pressure switch gauges
	7: 0-150 PSIG (0-10 BAR)	30"-0-200 PSIG/ -1-0-14 BAR	7: 0-400 PSIG/ 0-27 BAR	8: Diaphragm valve 1/8" tube fitting 9: Diaphragm valve 1/4" FPT		M06: 6mm	J: Protocol alarm station with standard transducer for non-hazardous environments
			8: 0-6000 PSIG/ 0-415 BAR <sup>1</sup>  G: 0-4000 PSIG/ 0-275 BAR <sup>2</sup>	A: 3/8" BSP RH fitting B: Diaphragm valve 3/8" fitting  C: 3/8" SP LH fitting D: 6mm brass hose barb (not available if A=4 or 5) G: 1/8" stainless steel tube fitting H: 1/4" stainless steel tube fitting  M: 6mm tube fitting S: Diaphragm valve 6mm tube fitting		CGA DIN 477 BS 341 and others available	K: Protocol switchover alarm station with standard transducer for non-hazardous environments  M: Protocol station Q: Protocol purge station T: Tee purge <sup>3</sup>  X: Protocol switchover alarm station with intrinsically safe transducer for hazardous environments

- Notes:**
- <sup>1</sup> Maximum inlet pressure 4500 PSIG (310 BAR) with PCTFE seat CAPSULE®
  - <sup>2</sup> Maximum inlet pressure 3500 PSIG (240 BAR) with PCTFE seat CAPSULE®
  - <sup>3</sup> Not available with 4500 PSIG (310 BAR) max inlet pressure

## Related Options

Part Number	Description
CON 550-0002	Panel mount kit
CON 550-0001	Captured vent kit
CON 476-0002	Helium leak certificate

## Installation Dimensions

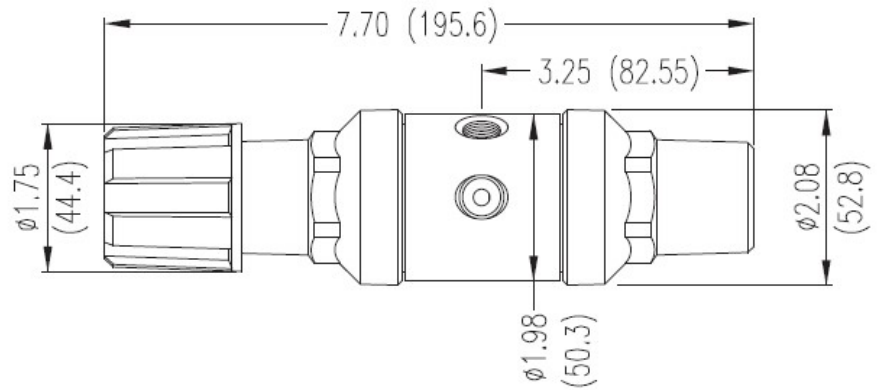
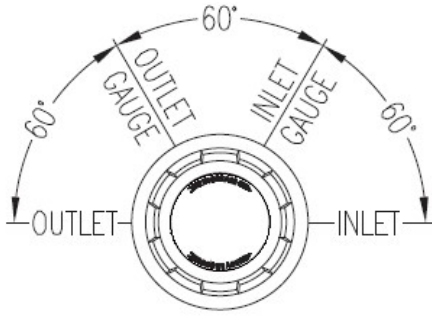

## 312 Regulator Flow Curves

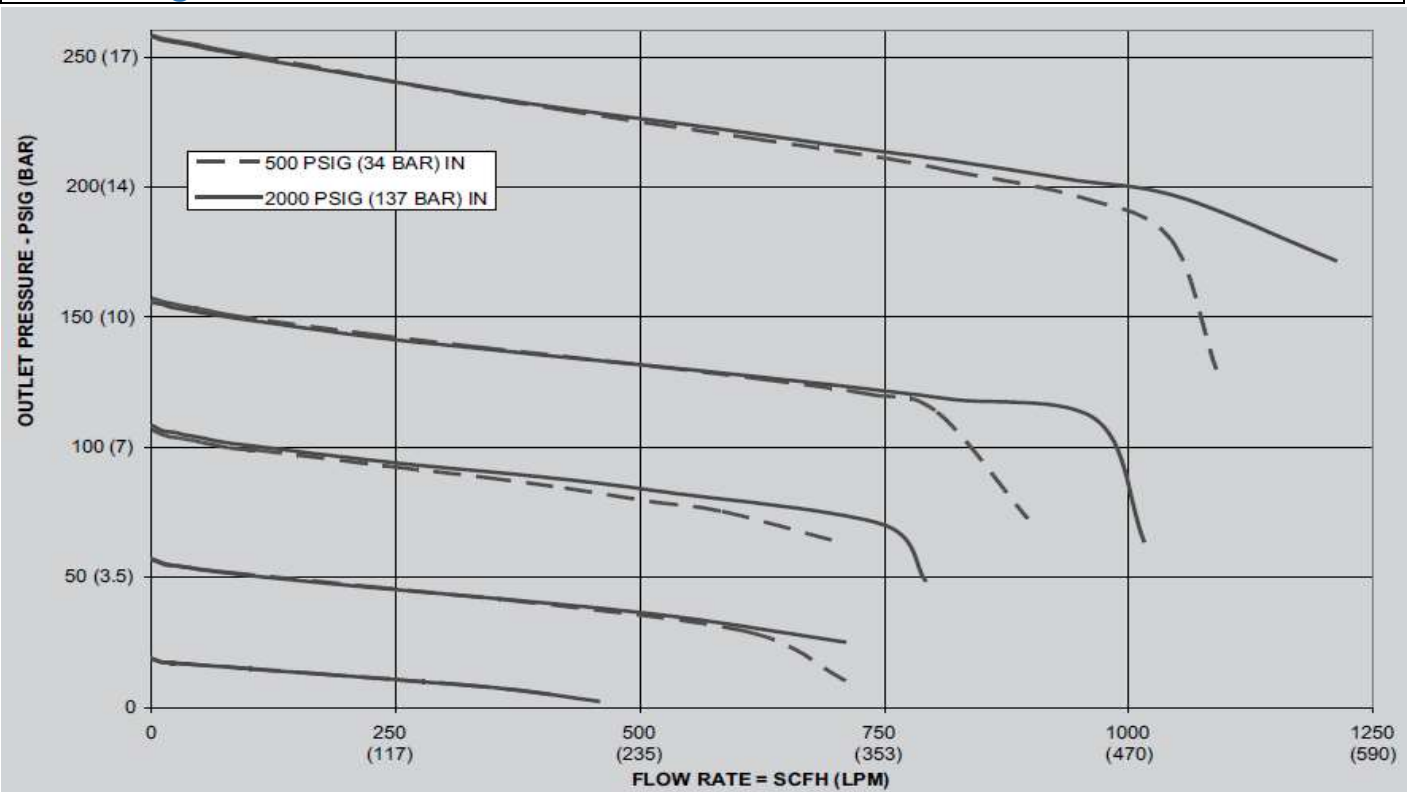

*Can't find what you need? We will be happy to assist you to find the right regulator to fit your needs.*