 PDi Communication Systems, Inc. Better Solutions Are Within Reach®	MODEL NUMBER: <b>PD168-059 Dual Monitor Mount</b>	Document Number: PD196-399R1
	INSTALLATION INSTRUCTIONS	Page 1 of 4

**SAFETY STEPS:**

- 1) Always wear safety glasses/goggles to prevent injury from debris.
- 2) Follow the installation/removal instructions for your existing products.

**TOOL LIST:**

- 1) P1 or P2, Phillips screw driver
- 2) 3/8", 7/16" wrenches
- 3) Safety glasses/goggles

**Mounting the monitors:**

- 1) Unpack the P19A TV (sold separately) and place on workbench face down. If necessary, place protective mat on workbench to ensure the viewing surface is not damaged.
- 2) Place the 15.6" Teguar Tablet (not provided by PDi) facedown next to the P19A TV so that it is on the right as shown in Figure 1.

FIGURE 1. MONITOR ARRANGEMENT

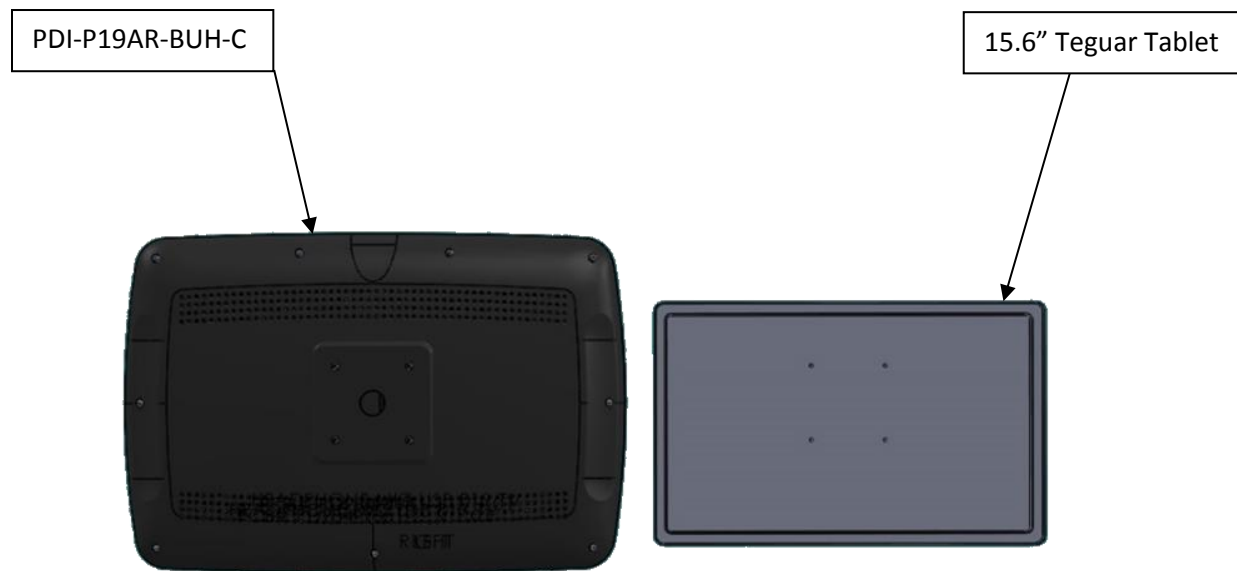

BOTTOM OF MONITORS

- 3) Remove the cover from the Dual Mount Arm as shown in Figure 2. Do not discard any of the parts as they will be needed later.

FIGURE 2. DUAL MOUNT ARM

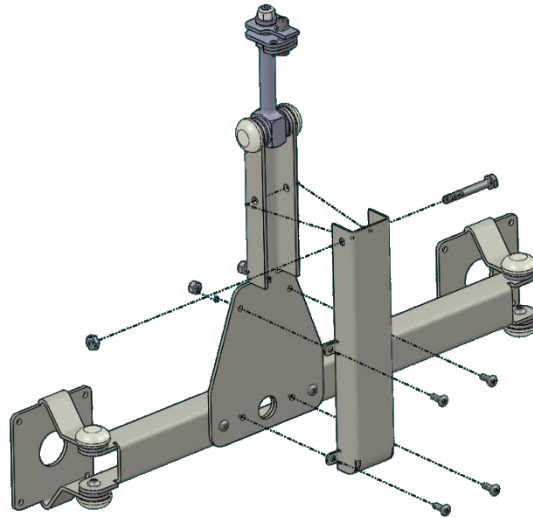

- 4) With the Dual Mount Arm oriented as shown in Figure 3, feed the cables from the P19A and the tablet through the 1.25" hole in the VESA mounting bracket for each monitor.

FIGURE 3. CONNECTING THE DUAL MOUNT ARM



- 5) Place the Dual Mount Arm on the back of each monitor and connect the monitors with the M4 x 10mm screws (4 each). See Figure 4.

 PDi Communication Systems, Inc. <i>Better Solutions Are Within Reach®</i>	MODEL NUMBER: <b>PD168-059 Dual Monitor Mount</b>	Document Number: PD196-399R1
	INSTALLATION INSTRUCTIONS	Page 3 of 4

FIGURE 4. SCREW INSTALLATION AND CABLE ROUTING



- 6) Attach the Dual Mount Arm to the nose of the PDI arm using the socket head cap screw (PD209-002) and lock washer(PDISLW25) from the Swivel Assembly in the Dual Mount Arm, as shown in Figure 5A & 5B.

FIGURE 5A. MOUNTING DUAL ARM TO SWING ARM

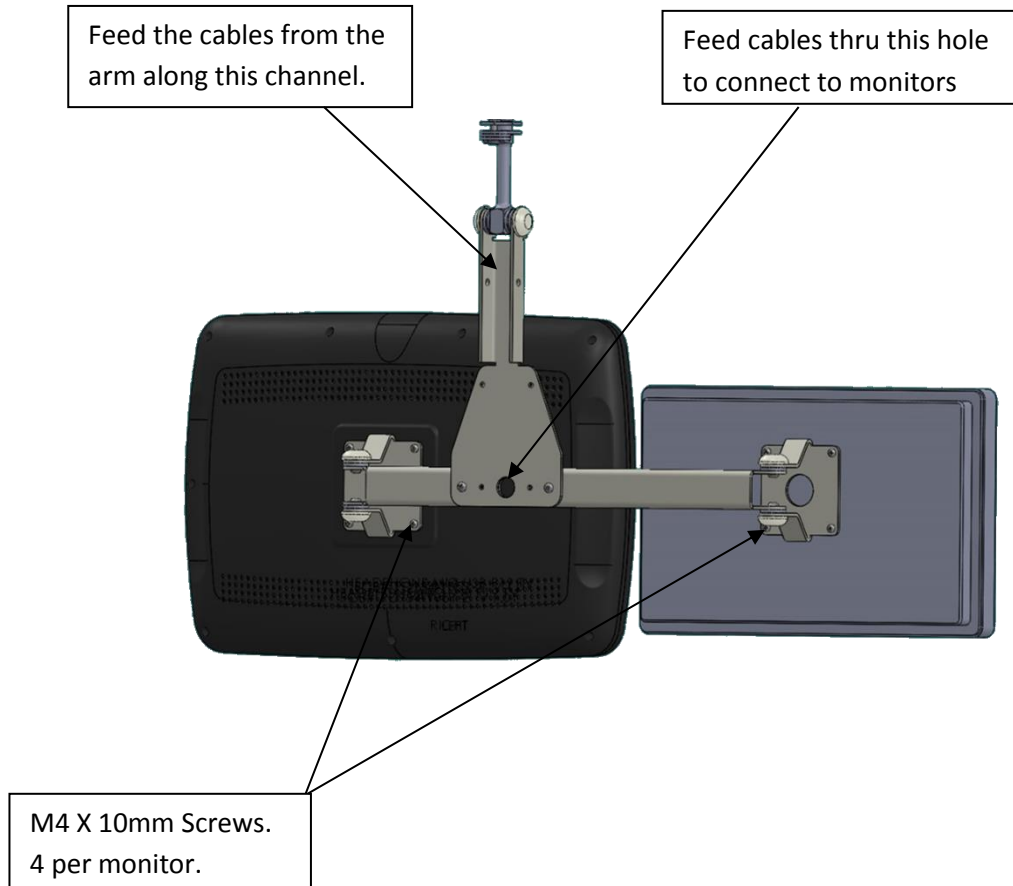
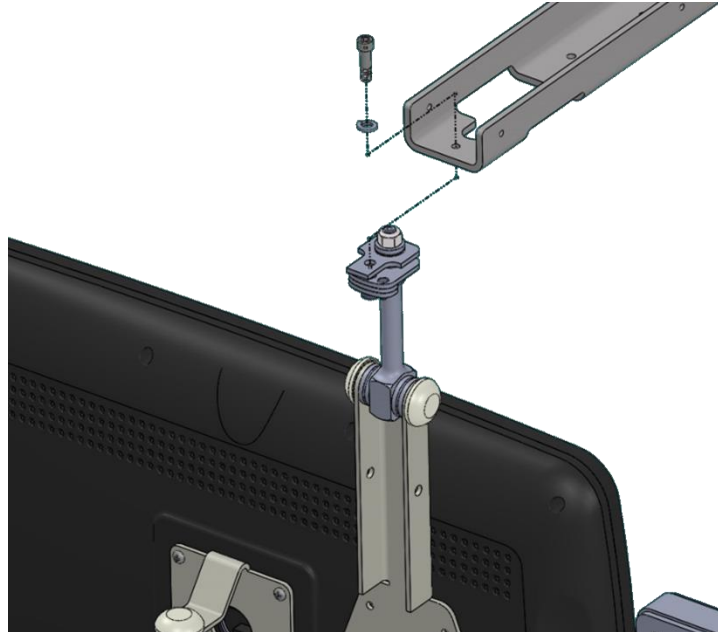

FIGURE 5B. MOUNTING DUAL ARM TO SWING ARM



- 7) Route cables through the Dual mount Arm as specified in Figure 4 and connect to the devices according to their respective installation documents.
- 8) Confirm the devices are working properly. Re-install the cover that was removed in step 3. Refer to Figure 2.