

BODY 75' HAL Aluminum Body COMPT, LEFT SIDE FRONT Full Height RollUp Forward COMPT, LEFT SIDE REAR Full Height RollUp Rearward COMPT, RIGHT SIDE FRONT Full Height RollUp Forward COMPT, RIGHT SIDE REAR Full Height RollUp Rearward	WATER TANK 500 Gallon Poly Water Tank Foam System Plumbing for Future Husky Foam System Foam Cell 20 Gallon Foam Cell, Non-Reduced Water
--	--

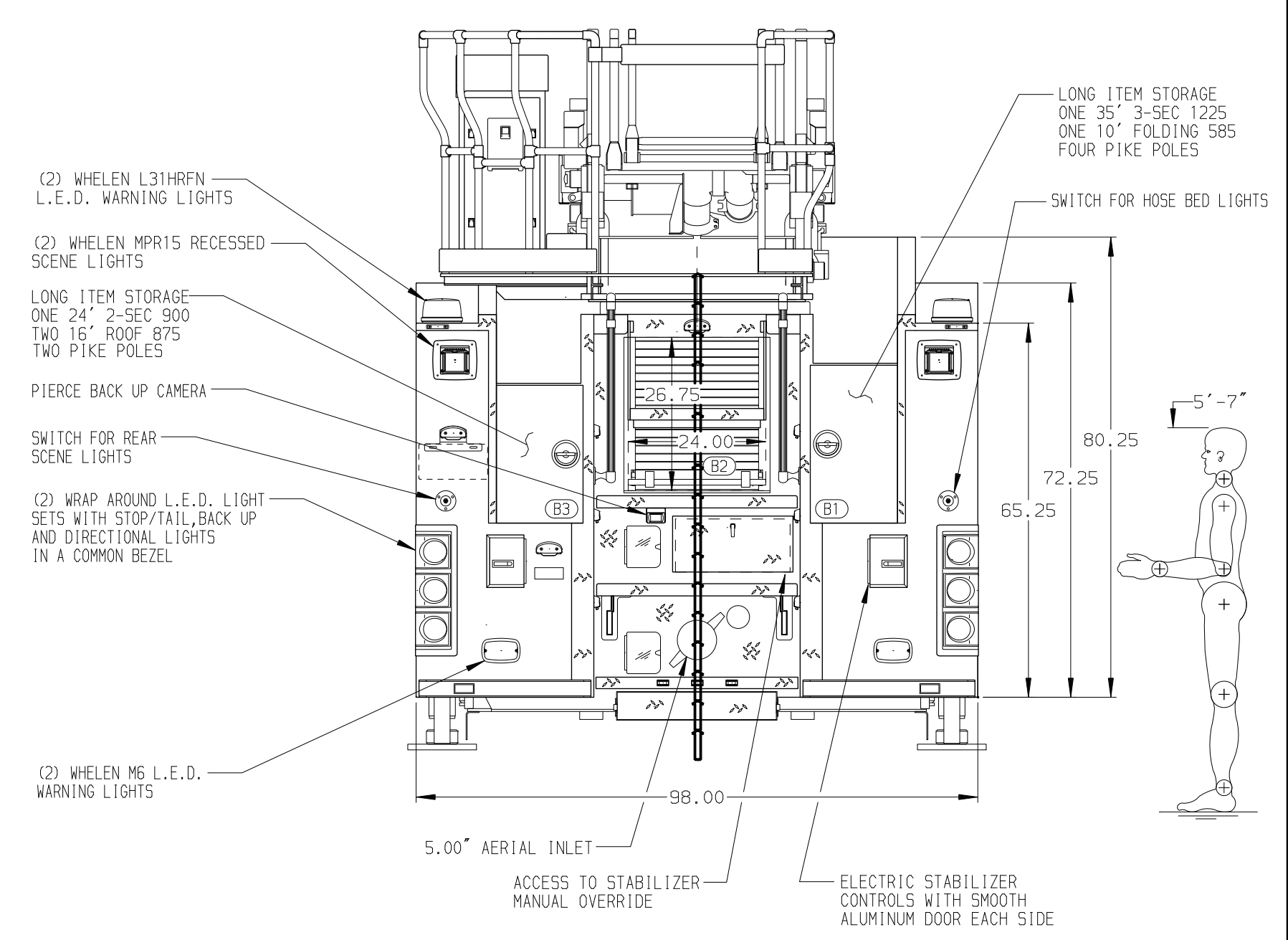
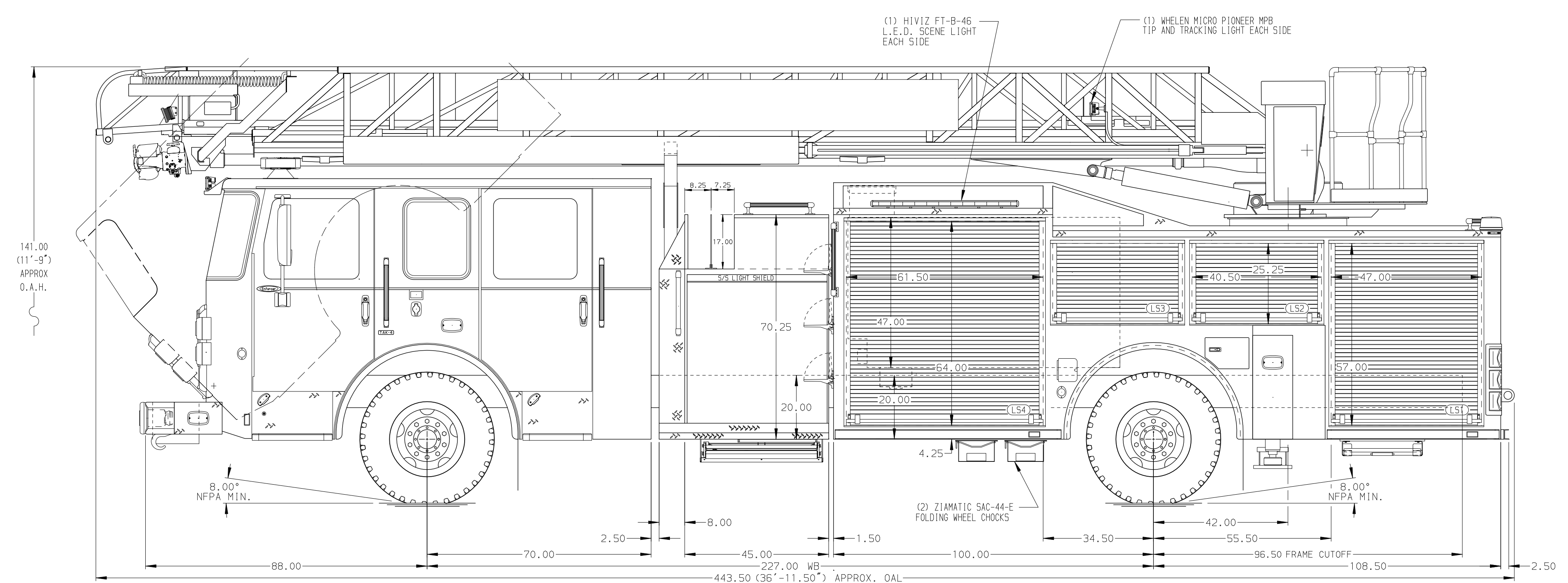

CHASSIS Enforcer Chassis ENGINE 450 HP Cummins L9 Engine	CAB 7000 Enforcer Cab BUMPER 19" Extended Stainless Steel	AXLE, FRONT, CUSTOM 19,500 Lb TAK-4 Axle AXLE, REAR 33,500 Lb Meritor Axle	TRANSMISSION Allison 5th Gen, 3000 EV5 P	PUMPHOUSE 45" Control Zone Side Mount PUMP 1500 GPM Waterous CSU	CROSSLAYS, 1.50" (2) 1.50" Standard Capacity CROSSLAYS, 2.50" 2.50" Crosslay Not Required	SPEEDLAYS Speedlays Not Required GENERATOR Generator Not Required	CUSTOMER APPROVAL APPROVED BY: _____ DATE: _____		JOB NO. 36623 SCALE 1:24 DATE DRAWN BY TKA 26MAR21 CHECKED BY THS 26MAR21 SHEET SIZE D SHEET NO. 1 OF 1	
NOTE DIMENSIONS SHOWN ARE APPROXIMATE AND ARE SUBJECT TO MINOR DEVIATIONS AS MAY OCCUR OR BE NECESSARY IN CONSTRUCTION. MINOR DETAILS NOT SHOWN.		1. ONE 1.50 OUTLET WITH 2.00 PIPING AND SWIVEL LOCATED IN CENTER BUMPER TRAY 2. SHORELINE RECEPTACLE WITH KUSSMAUL SUPER AUTO-EJECT LOCATED ON DRIVER SIDE OF THE CAB 3. AIR INLET WITH DISCONNECT COUPLING IN THE DRIVER SIDE STEPPWELL 4. BATTERY CHARGE INDICATOR LOCATED BEHIND DRIVER SEAT 5. BATTERY CHARGE INDICATOR LOCATED ON DRIVER SIDE OF THE CAB 6. DUAL L.E.D. LIGHT STRIPS LOCATED IN HOSE BED 7. FOUR ADJUSTABLE SHELVES IN COMPARTMENTS PER SHOP ORDER 8. FOUR FLOOR MOUNTED SLIDE-OUT TRAYS LOCATED IN COMPARTMENTS PER SHOP ORDER 9. 7.00" AERIAL LIMITED RETRACTION 10. MOUNTING PROVISIONS FOR FRONT INLET		11. 1.50" RAISED AERIAL PEDESTAL 12. 1500 GPM HIGH FLOW WATERWAY 13. LIFTING EYE RESCUE ATTACHMENT AT AERIAL TIP		CHASSIS DATA MAKE PIERCE MODEL ENFORCER TITLE 75 AERIAL LADDER & BODY ASSEMBLY (HAL) FOR PIERCE FIELD UNIT APPLETON, WI DWG NO. 36623AD				