

- HOSEBED CAPACITIES**
- ① 200' OF 1.75" D.J. POLY HOSE
 - ② 200' OF 1.75" D.J. POLY HOSE
 - ③ 1000' OF 4.00" D.J. POLY HOSE
 - ④ 200' OF 2.50" D.J. POLY HOSE
 - ⑤ 400' OF 3.00" D.J. POLY HOSE
 - ⑥ BACKBOARD

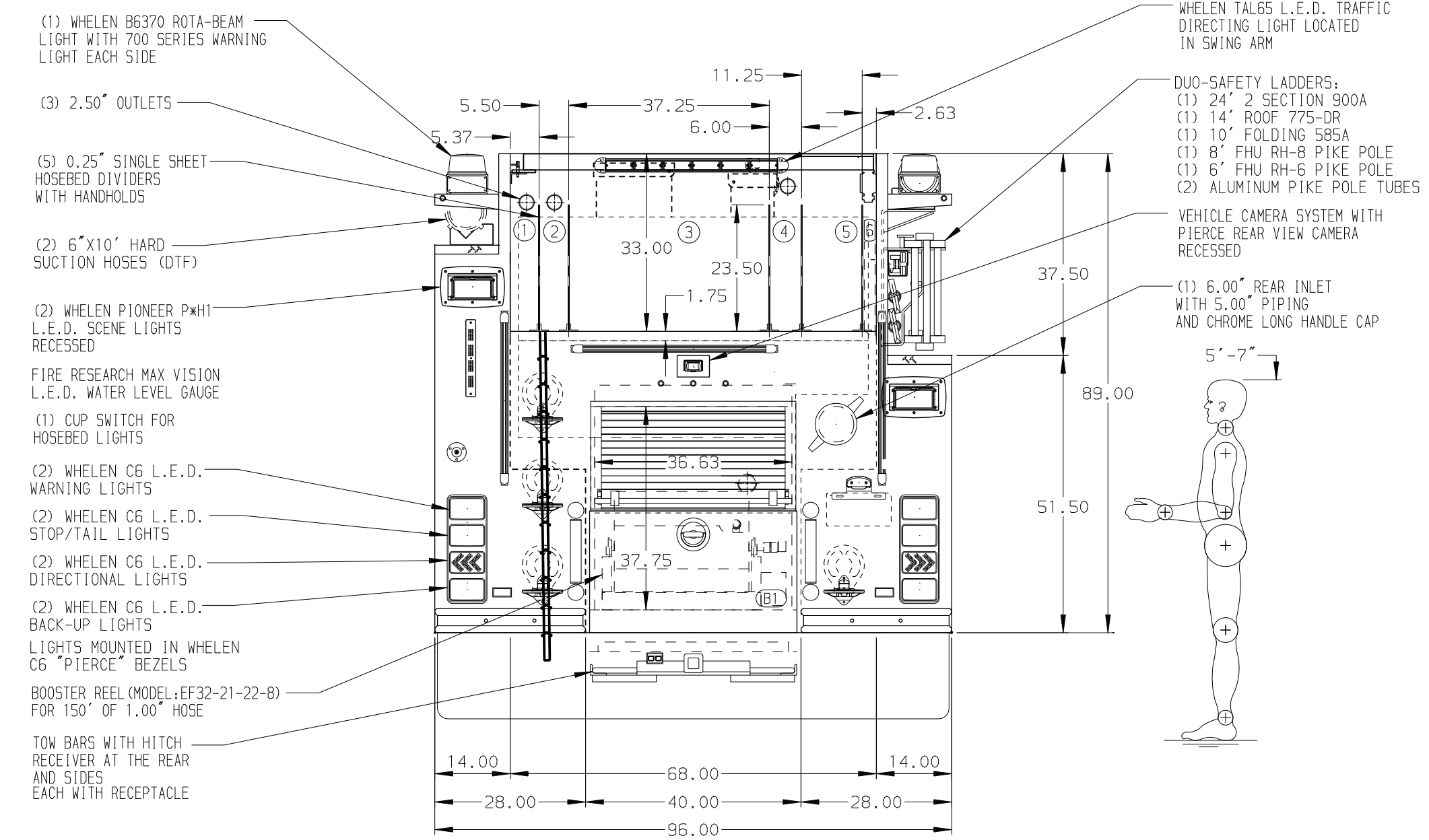
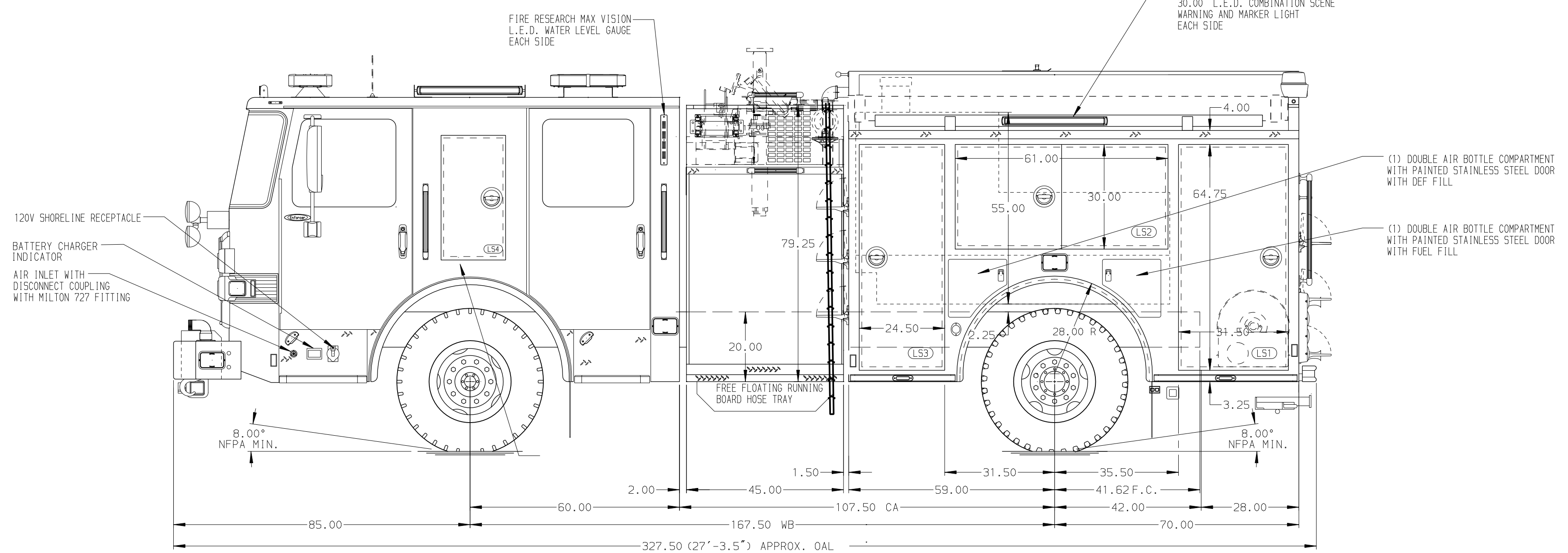

ALUMINUM BODY MAXIMUM O.A.H. 113.00" MAXIMUM O.A.L. 327.50"

NOTE
 DIMENSIONS SHOWN ARE APPROXIMATE AND ARE SUBJECT TO MINOR DEVIATIONS AS MAY OCCUR OR BE NECESSARY IN CONSTRUCTION. MINOR DETAILS NOT SHOWN.

1. AIR OUTLET WITH SHUT-OFF VALVE LOCATED LS PUMP PANEL
2. BATTERY CHARGER LOCATED IN EMS COMPARTMENT
3. DUAL L.E.D. LIGHT STRIPS LOCATED IN HOSE BED
4. REVERSED HINGED DOOR ON COMPARTMENT LS3
5. DRIP PAN GUARD FOR ROLL-UP DOOR LOCATED B1
6. ONE FULL WIDTH/DEPTH ADJUSTABLE SHELF IN COMPARTMENTS RS1, RS3, B1; TWO IN LS1, LS3
7. ONE FLOOR MOUNTED SLIDE-OUT TRAY IN COMPARTMENTS LS1, LS3, RS1
8. ONE SWING-OUT ALUMINUM TOOL BOARD IN COMPARTMENT LS2
9. CIRCUIT BREAKER PANEL IN COMPARTMENT LS3
10. MOUNTING BRACKETS FOR CHOCKS PROVIDED BY DEALER

REV	DATE	BY	CH	ENFORCER
1	26JUL21	LME	CSH	CHASSIS DATA
2	12JUL21	LME	CSH	MAKE
3	25JUN21	LME	CSH	PIERCE
4	17MAR21	LME	CDU	MODEL

		JOB NO.	36078
		SCALE	DATE
TITLE	1500-D-770P, 750 WATER W/20 FOAM CELL, 129" BODY DELUGE, BOOSTER REEL, LADDERS BETWEEN TANK AND BODY		
FOR	WOODSTOCK FIRE DEPARTMENT WOODSTOCK, VIRGINIA		
DWG NO.	36078AD		
DRAWN BY	LME	CHECKED BY	CDU
SHEET SIZE	D	SHEET NO.	1 OF 1