

- HOSEBED CAPACITIES
- ① 600' OF 2.50" D.J. POLY HOSE
  - ② 600' OF 2.50" D.J. POLY HOSE
  - ③ 750' OF 5.00" D.J. POLY HOSE

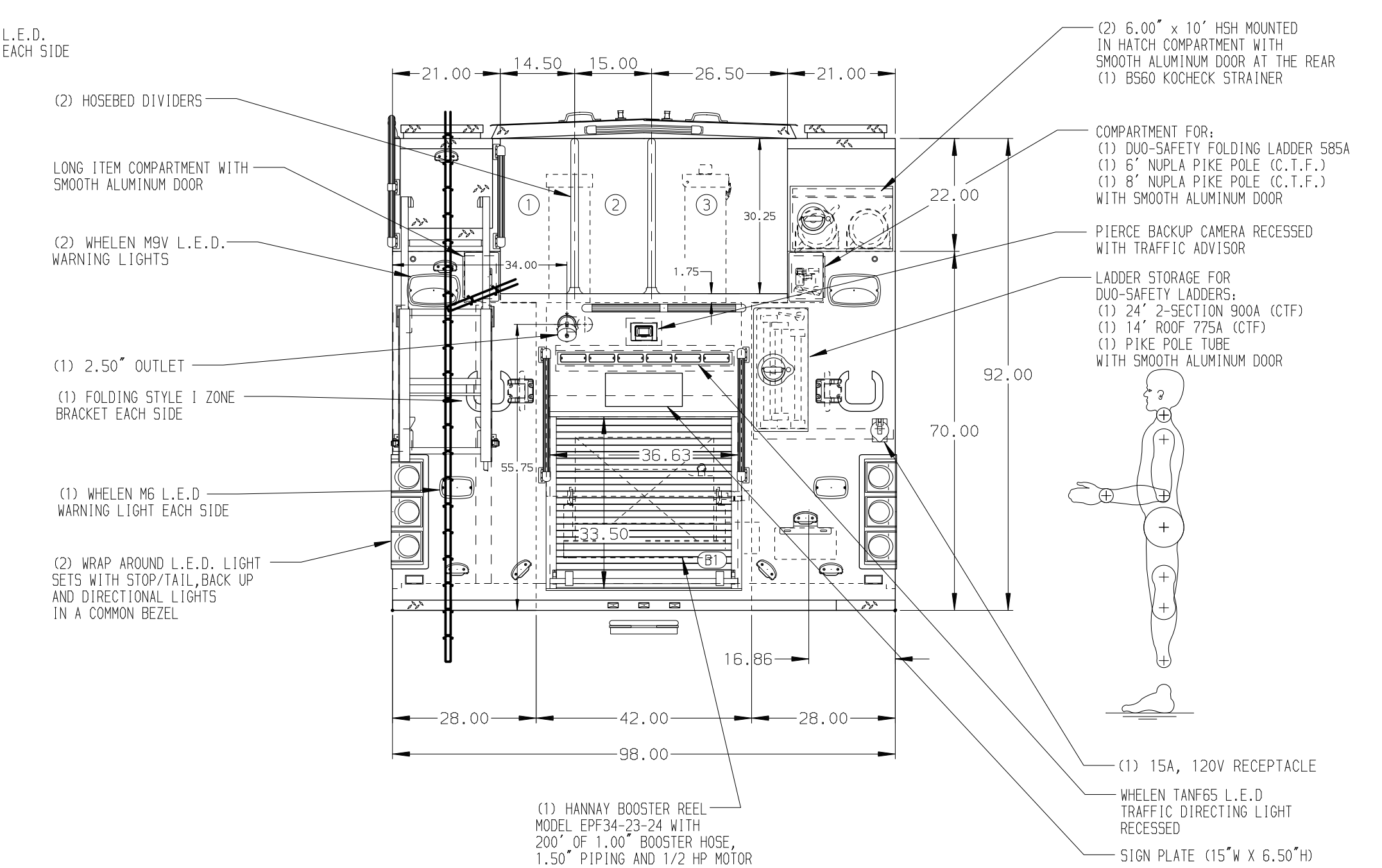
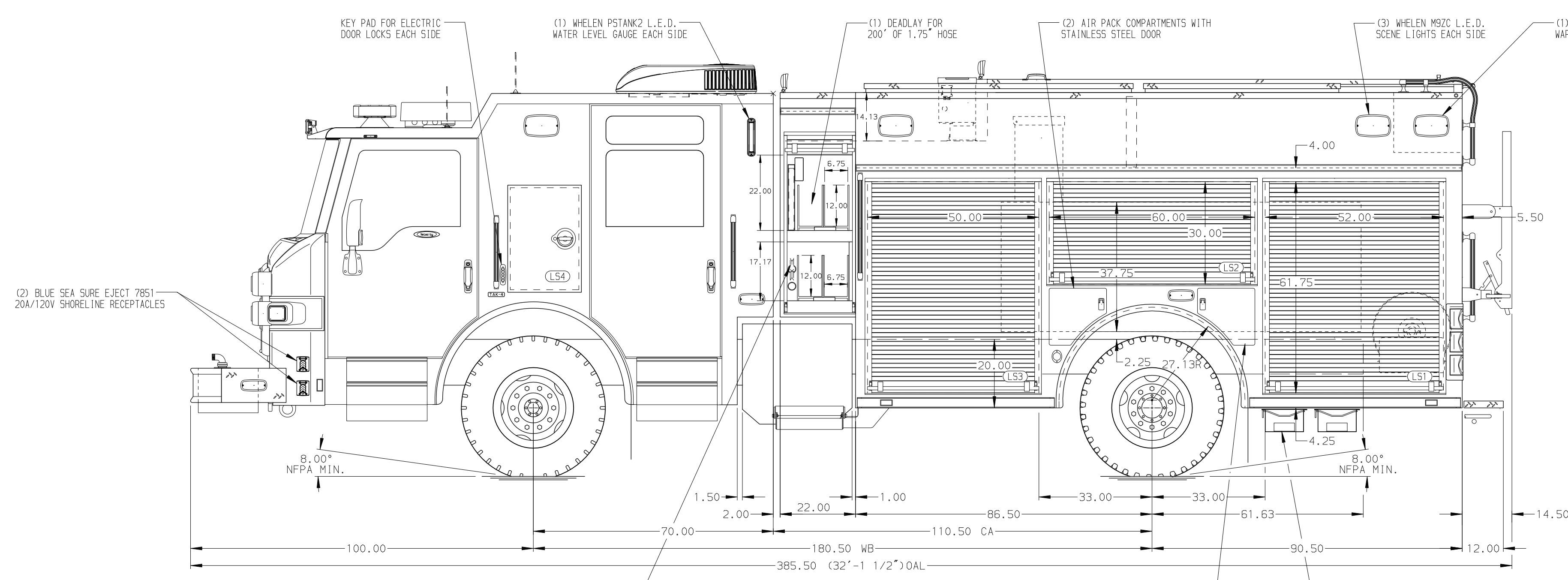

ALUMINUM BODY

FRONTAL IMPACT PROTECTION

NOTE  
DIMENSIONS SHOWN ARE APPROXIMATE AND ARE SUBJECT TO MINOR DEVIATIONS AS MAY OCCUR OR BE NECESSARY IN CONSTRUCTION. MINOR DETAILS NOT SHOWN.

- 1. ONE FULL WIDTH/DEPTH ADJUSTABLE SHELF IN COMPARTMENTS LS2 & RS2; TWO IN RS1; FOUR IN RS3
- 2. ONE TOOLBOARD MOUNTED TO FLOOR MOUNTED SLIDE-OUT TRAY IN COMPARTMENT LS3
- 3. ONE FLOOR MOUNTED SLIDE-OUT TRAY WITH 2" SIDES IN COMPARTMENT LS3
- 4. ONE VERTICAL DIVIDER IN COMPARTMENT RS3
- 5. CTECH TWO DRAWER ASSEMBLY IN COMPARTMENT LS3
- 6. PLUMBING DIAGRAM REQUIRED
- 7. AIR INLET/OUTLET WITH DISCONNECT FITTING LOCATED AT RS & LS PUMP PANELS
- 8. ONE HORIZONTAL PARTITION LOCATED IN COMPARTMENT LS3
- 9. LITTLE GIANT LADDER LOCATED IN COMPARTMENT LS1
- 10. ONE VERTICAL PARTITION LOCATED IN COMPARTMENT LS1
- 11. PARTITION BETWEEN COMPARTMENTS LS1/B1 AND RS1/B1

REV	DATE	BY	CH	VELOCITY
02JUN21	JRO	PJP		CHASSIS DATA
28APR21	JRC	ZWE		MAKE PIERCE
12FEB21	LST	WKL		MODEL

		JOB NO.	35938
		SCALE	1:24
TITLE	1500-525 WATER/30 FOAM, 177" BODY, CROSSLAYS/DEADLAY LADDERS BETWEEN TANK & SIDE SHEET, DELUGE, HUSKY 3	DRAWN BY	JRO
FOR	CLOVIS FIRE DEPARTMENT CLOVIS, CALIFORNIA	CHECKED BY	WKL
DWG NO.	35938AD	SHEET SIZE	D
		SHEET NO.	1 OF 1