

RIGHT SIDE COMPARTMENTS CONTAIN THE FOLLOWING:

COMPARTMENT RS1 CONTAINS:
 - (2) SHELVES, ADJUSTABLE, 500LB CAP, STANDARD DEPTH COMPT

COMPARTMENT RS2 CONTAINS:
 - (1) TRAY, SLIDE OUT, TWO WAY, TRANSVERSE COMPT, 500LB CAPACITY
 - TOOLBOARD, ON SLIDE-OUT TRAY, FULL DEPTH/ TRANSVERSE, 2/WAY, 188" PEG BOARD

COMPARTMENT RS4 CONTAINS:
 - (1) TRAY, SLIDE OUT, TILT 30°, 1/2 DEPTH OF TRANSVERSE COMPT, 200* CAPACITY
 - (1) TRAY, SLIDE OUT, 1/2 TRANSVERSE, ADJUSTABLE HEIGHT, 500LB CAPACITY
 - (1) EXTENDED COMPARTMENT FLOOR BOLT IN STYLE

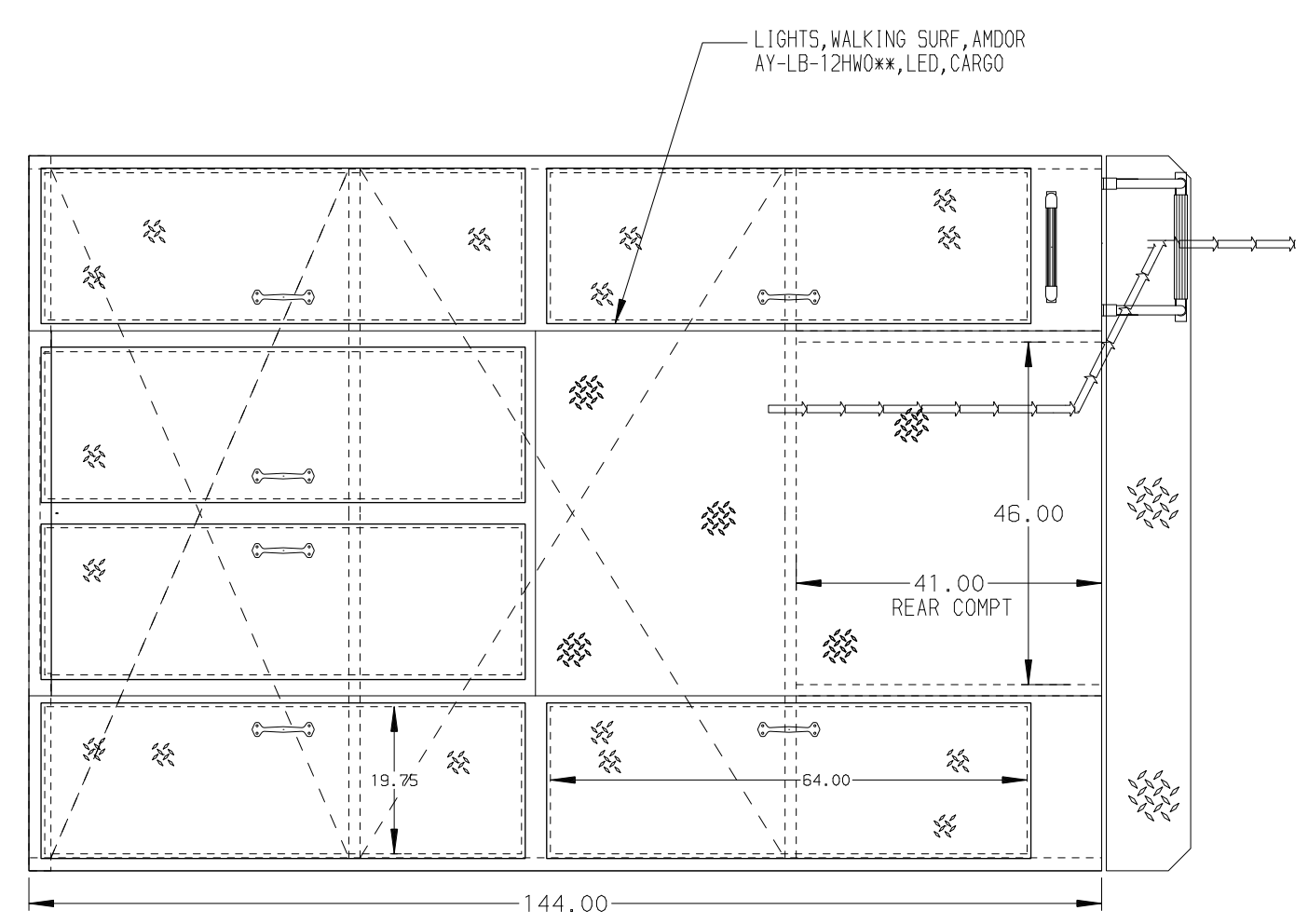
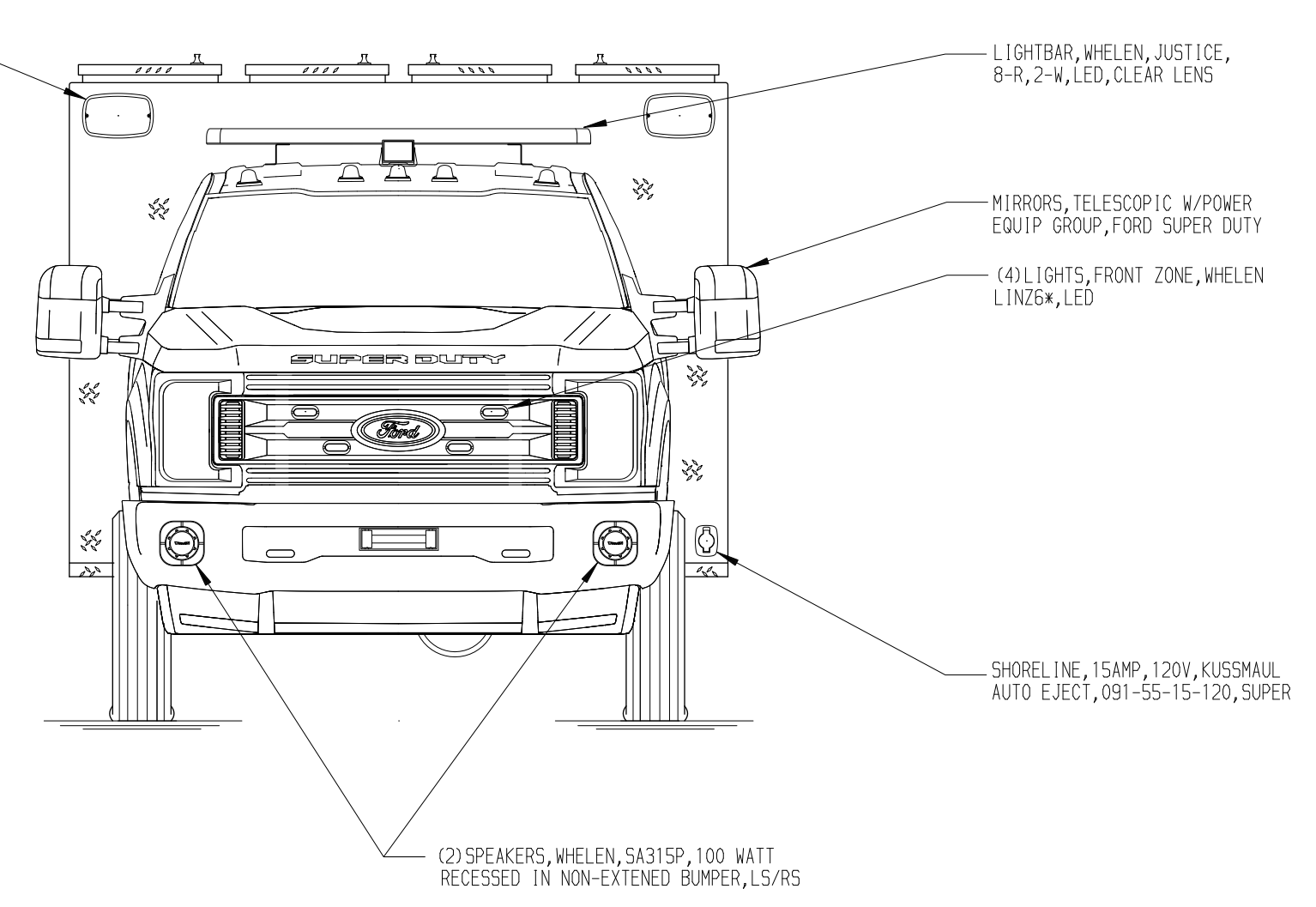
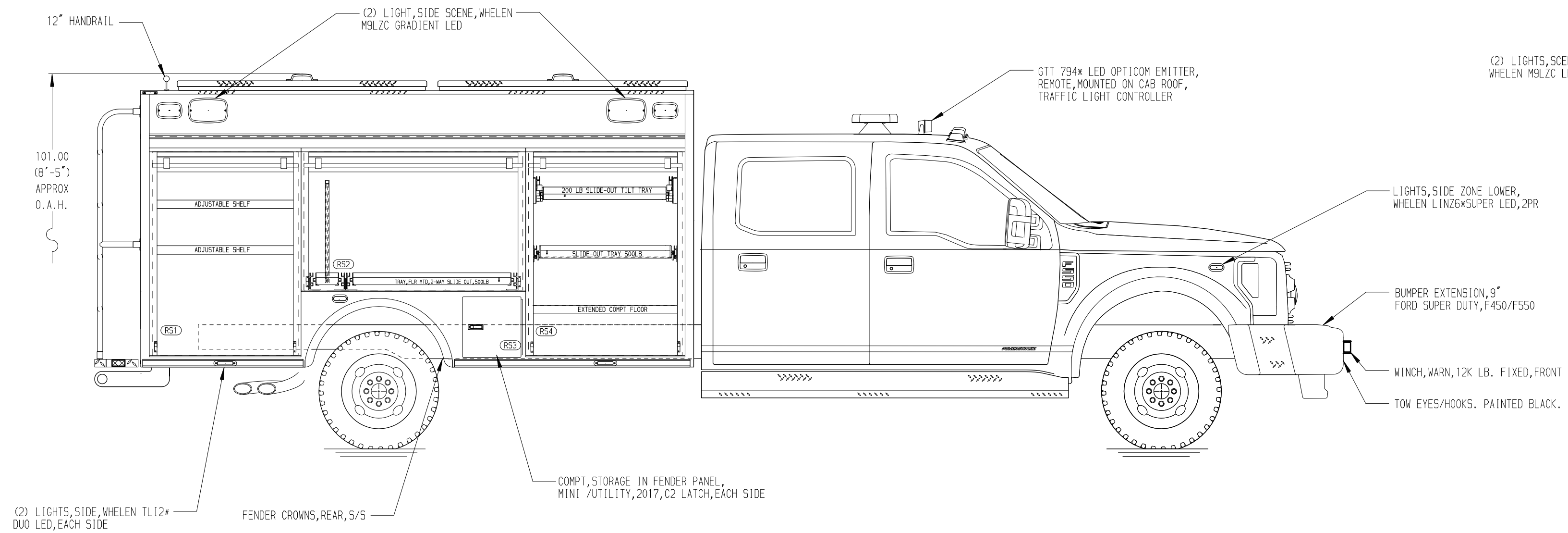

REAR COMPARTMENT B1 CONTAINS THE FOLLOWING:

- (1) TRAY, SLIDE-OUT, FULL DEPTH, B1 COMPT, ADJUSTABLE HEIGHT, 500LB CAPACITY
 - (1) TRAY, SLIDE-OUT, FULL DEPTH, B1 COMPT, 500LB CAPACITY

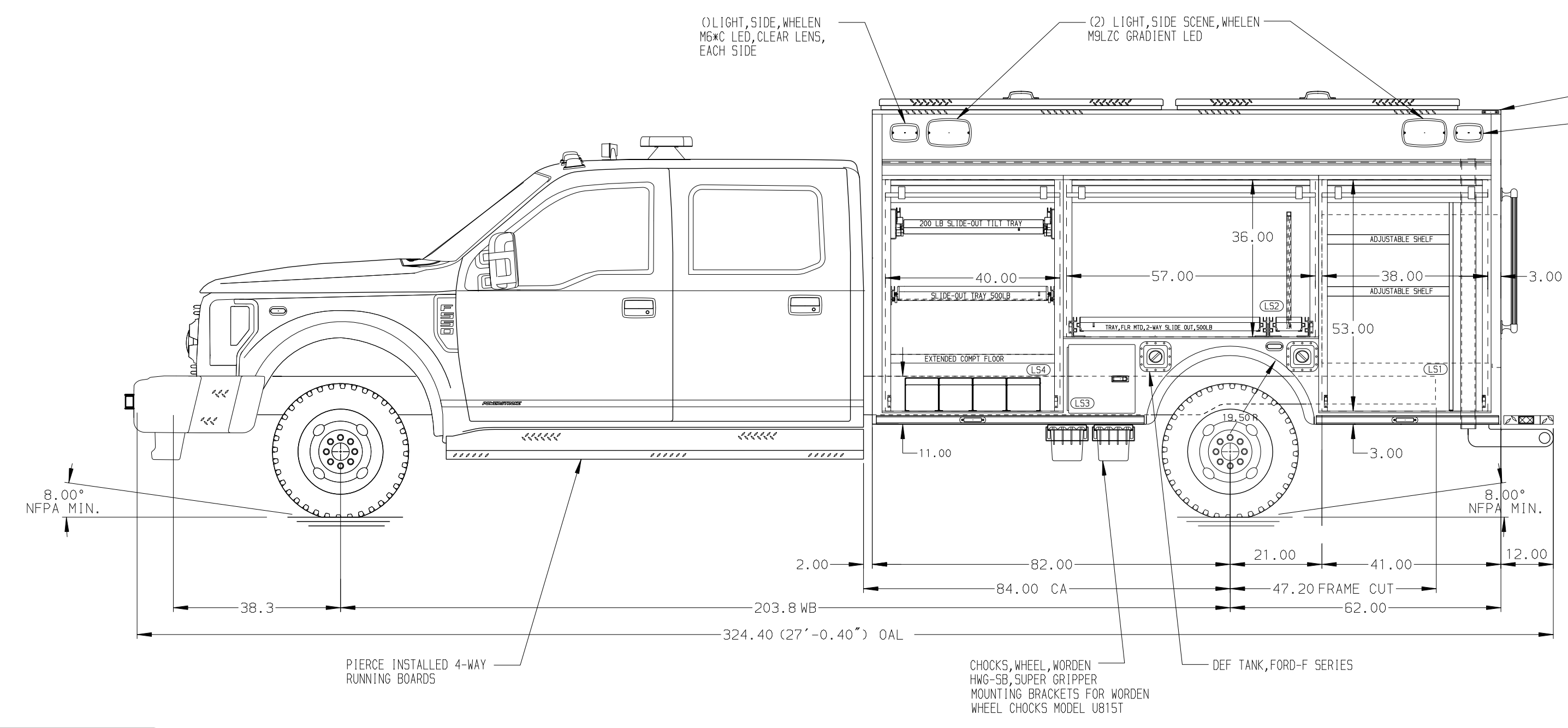

LEFT SIDE COMPARTMENTS CONTAIN THE FOLLOWING:

COMPARTMENT LS1 CONTAINS:
 - (2) SHELVES, ADJUSTABLE, 500LB CAP, STANDARD DEPTH COMPT
 - (1) COMPARTMENT DIVIDER, VERTICAL
 - (1) HOPPER, OIL DRY ABSORBENT, ROOF HATCH, THRU FLOOR, 125LB CAPACITY

COMPARTMENT LS2 CONTAINS:
 - (1) TRAY, SLIDE OUT, TWO WAY, TRANSVERSE COMPT, 500LB CAPACITY
 - TOOLBOARD, ON SLIDE-OUT TRAY, FULL DEPTH/ TRANSVERSE, 2/WAY, 188\"/>

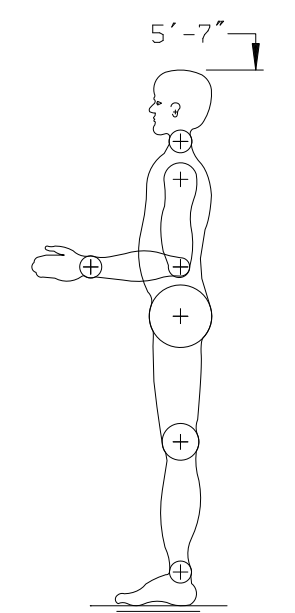
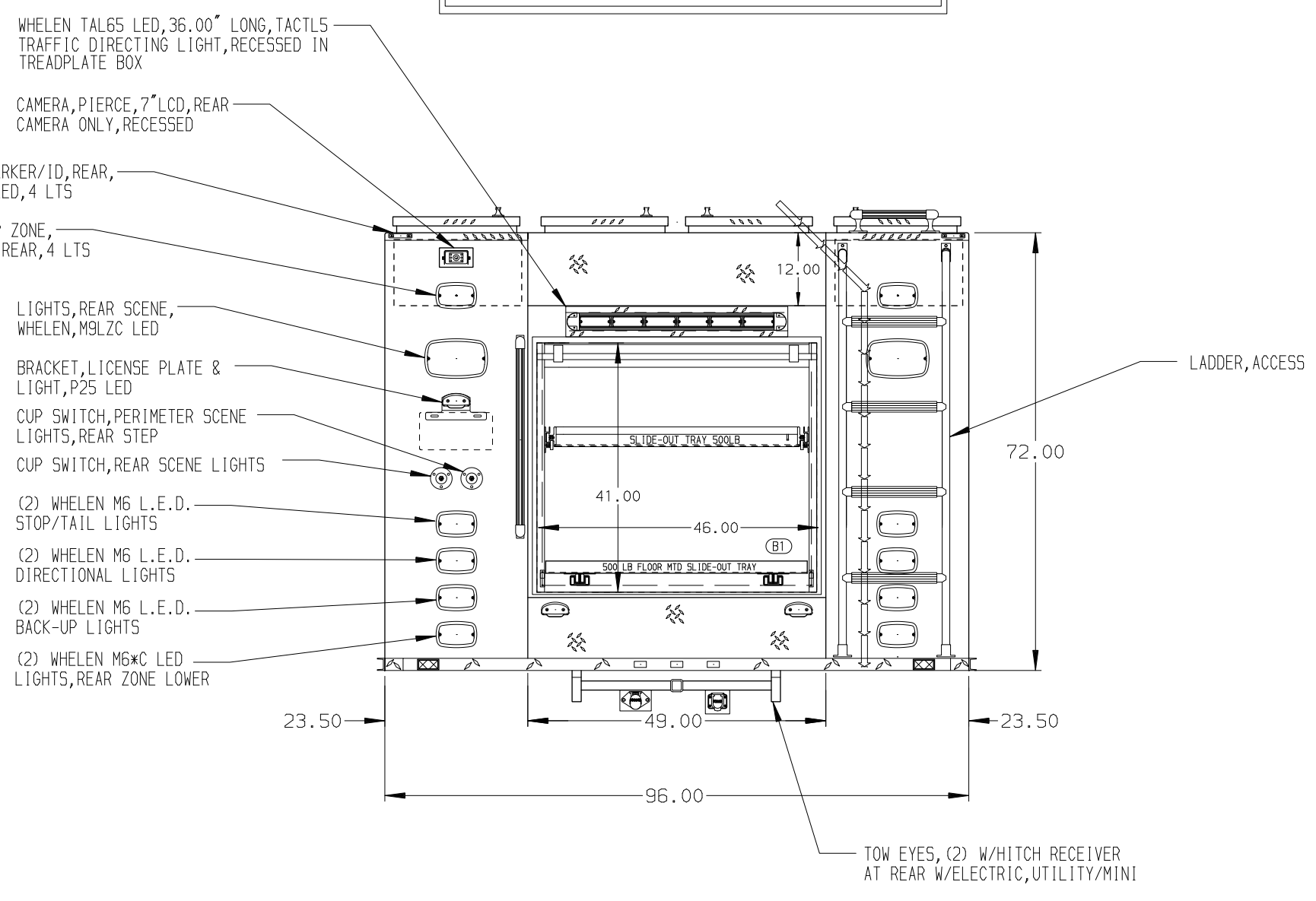

ALUMINUM BODY

NOTE
 DIMENSIONS SHOWN ARE APPROXIMATE AND ARE SUBJECT TO MINOR DEVIATIONS AS MAY OCCUR OR BE NECESSARY IN CONSTRUCTION. MINOR DETAILS NOT SHOWN.

		JOB NO.	35445
		DATE	08JUL20
MANUFACTURING INC. BRADENTON, FLORIDA		SCALE	1:24
		TITLE	12' RESCUE, NON-WALK-IN
FOR		DRAWN BY	CRH
		CHK'D BY	RWI
MODEL F-550 4X4		SHEET NO.	1 OF 1
		SHEET SIZE	D

REV.	DATE	BY	CHK'D	CHASSIS DATA
05OCT20	RHU	AJA		CHASSIS DATA
25SEP20	RHU	AJA		CHASSIS DATA
10SEP20	JLA	AJA		FORD
31JUL20	CRH	RWI		MODEL F-550 4X4

35445AD