

LEFT SIDE COMPARTMENTS CONTAIN THE FOLLOWING:

- COMPARTMENT L51 CONTAINS:
  - (2) WHEEL CHOCKS
  - (2) SPARE TIRE CARRIER WINCH REMOTE
- COMPARTMENT L52 CONTAINS:
  - (2) SHELF, ADJUSTABLE, 500 LB CAPACITY, 5/5, UNPAINTED, W/SECONDARY RETENTION
- COMPARTMENT L53 CONTAINS:
  - (2) SHELVES, ADJUSTABLE, 500 LB CAPACITY, 5/5, UNPAINTED, W/SECONDARY RETENTION
- COMPARTMENT L54 CONTAINS:

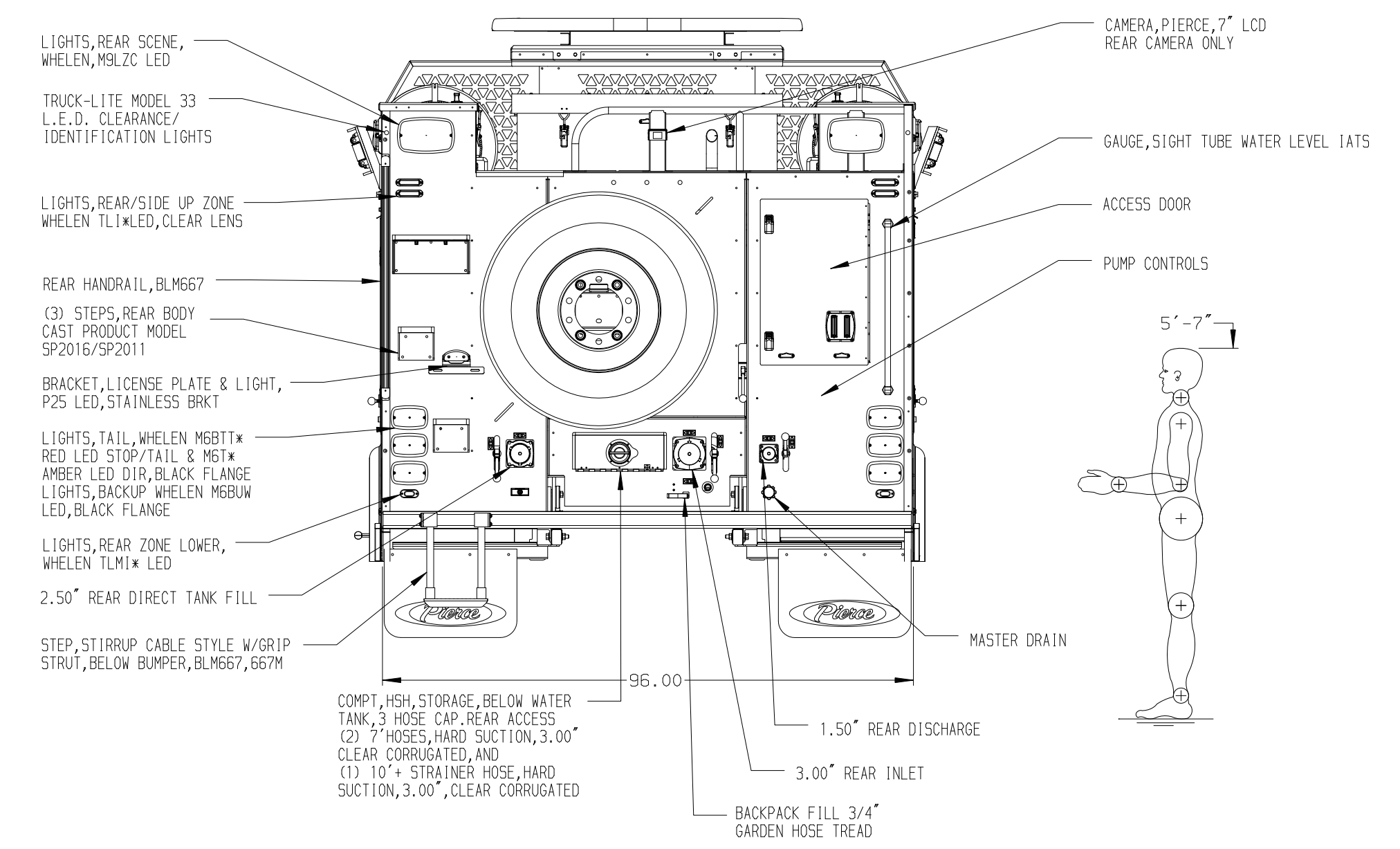

**STAINLESS STEEL BODY**

**NOTE**  
DIMENSIONS SHOWN ARE APPROXIMATE AND ARE SUBJECT TO MINOR DEVIATIONS AS MAY OCCUR OR BE NECESSARY IN CONSTRUCTION. MINOR DETAILS NOT SHOWN.

(800 GALLON WATER TANK 3598594)

NOTE: WINTERIZE BEFORE SHIPMENT, BLM667/667M

CHASSIS DATA	TITLE	800 GAL WATER W/20 FOAM, DARLEY, HSE 65K W/KUBOTA V2403T
MAKE	FOR	BLM WYOMING
FL		BOISE, IDAHO
MODEL M2-106 4x4	DWG NO.	35410AD

<b>Pierce</b> MANUFACTURING INC.	JOB NO.	35410
	SCALE	DATE
	1:24	
	DRAWN BY	JLA
	CHECKED BY	RWI
	SHEET SIZE	D
	SHEET NO.	1 OF 1