

- HOSEBED CAPACITIES**
- ① 1000' OF 4.00" RUBBER HOSE
  - ② 500' OF 2.50" D.J. POLY HOSE
  - ③ WALKWAY

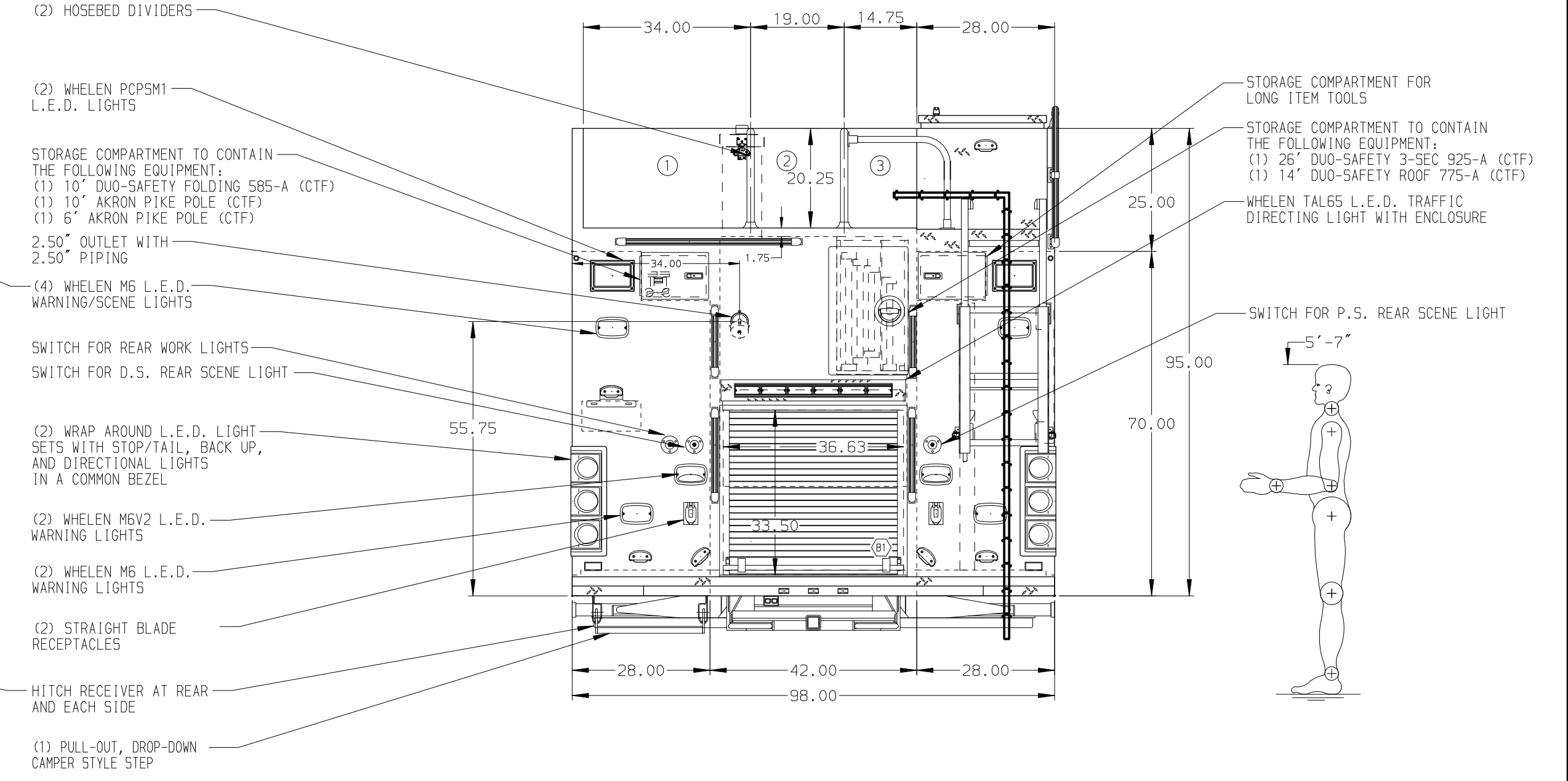
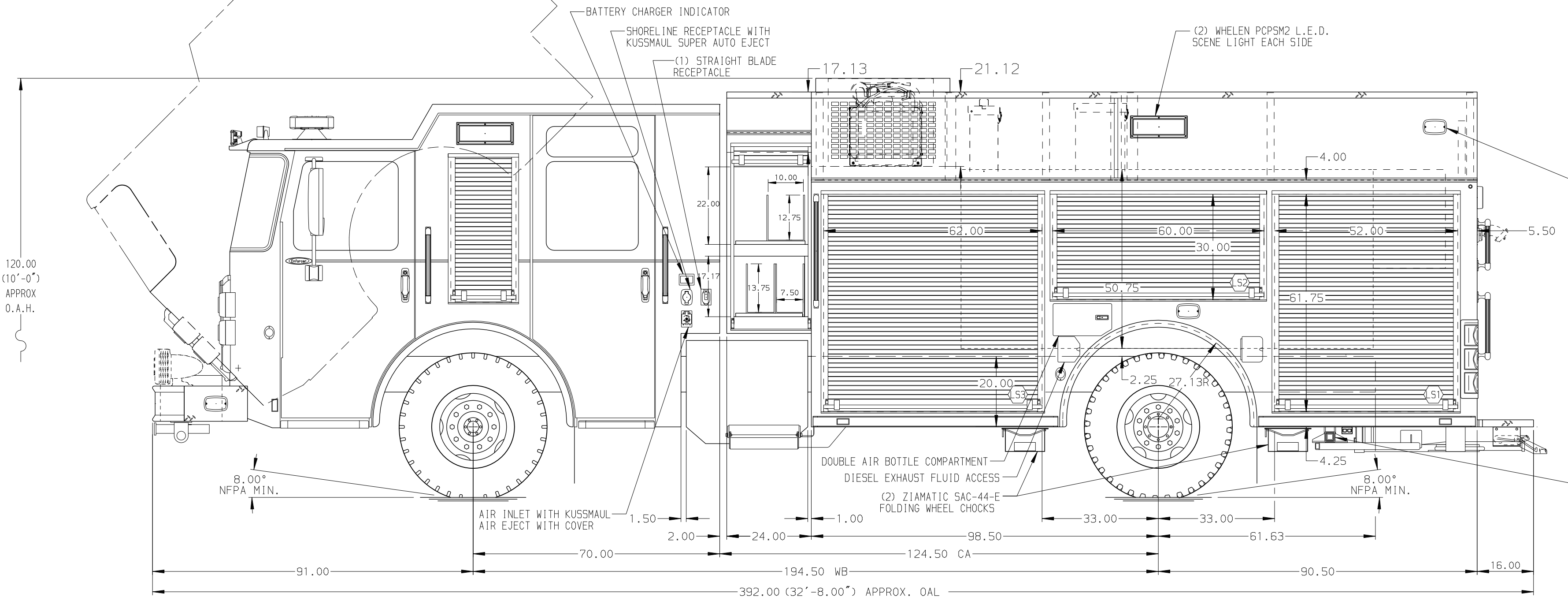

**ALUMINUM BODY**

**NOTE**  
DIMENSIONS SHOWN ARE APPROXIMATE AND ARE SUBJECT TO MINOR DEVIATIONS AS MAY OCCUR OR BE NECESSARY IN CONSTRUCTION. MINOR DETAILS NOT SHOWN.

1. OIL DRY HOPPER WITH 200 LBS. OF OIL DRY ABSORBENT IN HATCH COMPARTMENT ABOVE R53
2. BATTERY CHARGER LOCATED IN COMPARTMENT-L53
3. FULL WIDTH/DEPTH ADJUSTABLE SHELVES WITH 2" SIDES IN COMPARTMENT-TWO IN LS1,RS1, THREE IN LS3
4. ADJUSTABLE SLIDE-OUT TRAYS WITH 2" SIDES IN COMPARTMENT-R53,B1
5. ADJUSTABLE TILT/SLIDE-OUT TRAYS IN COMPARTMENT-LS1,LS2,RS3
6. FULL WIDTH/DEPTH FLOOR MOUNTED SLIDE-OUT TRAYS WITH 2" SIDES IN COMPARTMENT-LS1, RS1,RS3, & B1
7. SWING-OUT TOOLBOARD WITH PEGBOARD PATTERN IN COMPARTMENT-R52
8. VERTICAL PARTITION WITH PEGBOARD PATTERN IN COMPARTMENT-R51
9. L-SHAPED PARTITION LOCATED IN COMPARTMENT-LS3
10. PEGBOARD WITH TRACKS ON REAR WALL IN COMPARTMENT-R51
11. PEGBOARD WITH TRACKS ON SIDE WALL IN COMPARTMENT-R51
12. CIRCUIT BREAKER PANEL IN DRIVER SIDE FRONT BRASS COMPARTMENT
13. CAB LIFT WILL BE LOCATED ON PUMP PANEL
14. INSTA-CHAIN 6 STRAND AUTOMATIC TIRE CHAINS
15. VERTICAL PARTITION BETWEEN COMPARTMENTS LS1/B1 & RS1/B1

		JOB NO.	35120
		SCALE	1:24
<b>Pierce MANUFACTURING INC.</b>		TITLE	1500-D-600P W/40 GAL. FOAM CELL,DELUGE,GENERATOR
		FOR	189" PUC RESCUE BODY,LADDERS THRU TANK,HUSKY FOAM
		DRAWN BY	JCO
		CHECKED BY	EGO
		SHEET SIZE	D
		SHEET NO.	1 OF 1

27OCT20	JRC	-	MAKE
24SEP20	JRC	-	PIERCE
08JUL20	JCO	EGO	MODEL
REV	DATE	BY	CH

DWG NO. **35120AD**