

BODY	WATER TANK
107' ASL Aluminum Body	500 Gallon Poly Water Tank
COMPT, LEFT SIDE FRONT	Foam System
Full Height Lap Forward	Foam System Not Required
COMPT, LEFT SIDE REAR	Foam Cell
Full Height Lap Rearward	Foam Cell Not Required
COMPT, RIGHT SIDE FRONT	
Full Height Lap Forward	
COMPT, RIGHT SIDE REAR	
Full Height Lap Rearward	

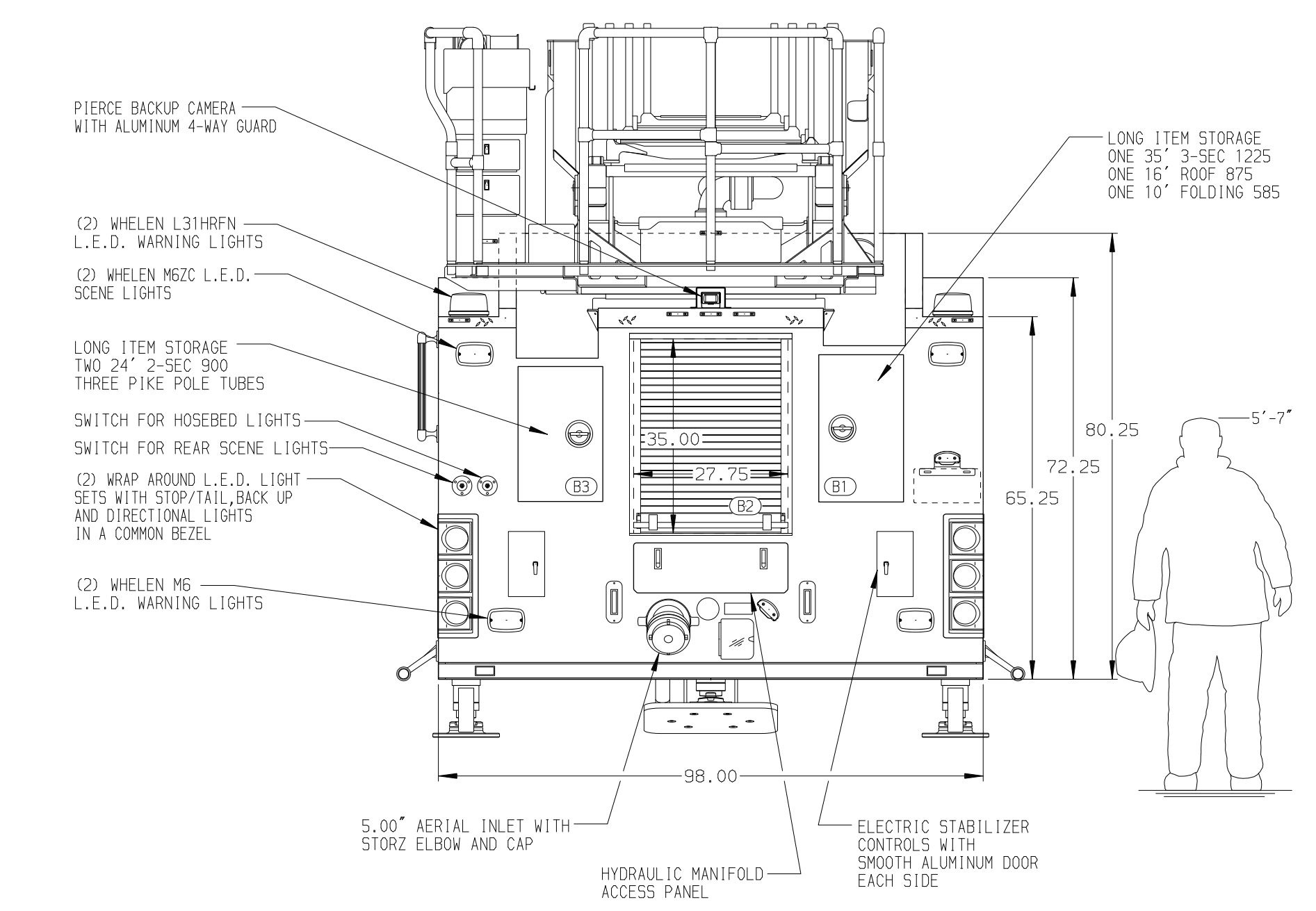
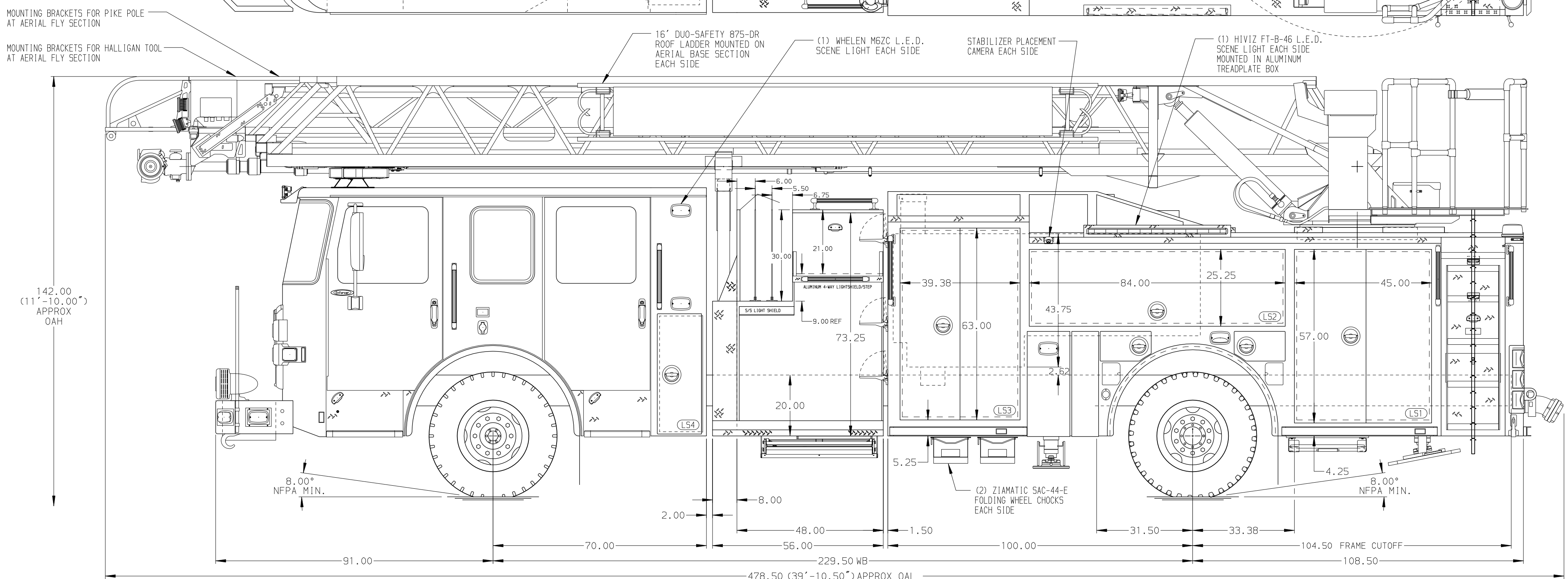
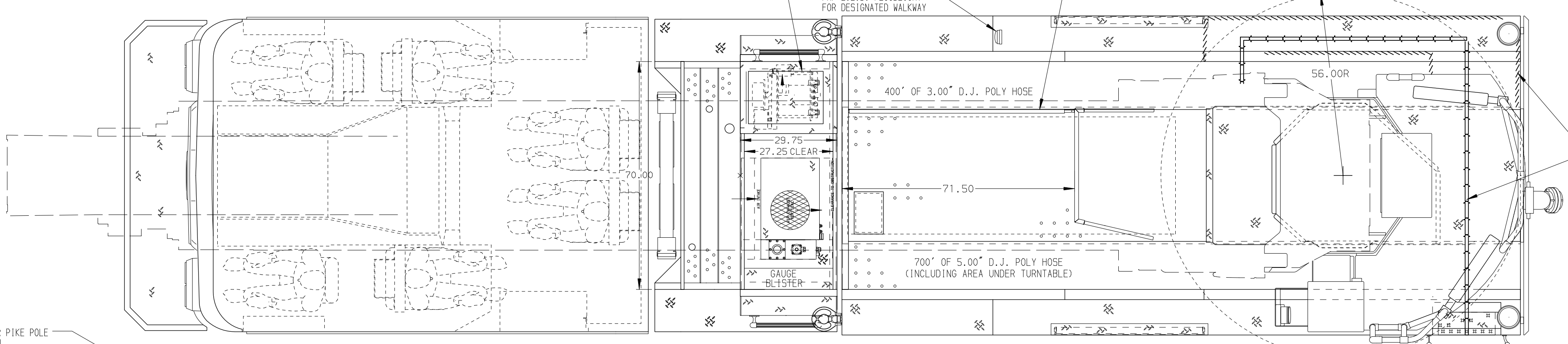

CHASSIS Enforcer Chassis 450 HP Cummins L9 Engine	CAB 7000 Enforcer Cab 22" Extended Painted Steel	AXLE, FRONT, CUSTOM 22,000 Lb Dana Axle AXLE, REAR 33,500 Lb Meritor Axle	TRANSMISSION Allison 5th Gen, 3000 EV5 P	PUMPHOUSE 48" Control Zone Side Mount 2000 GPM Hale QMAX-200	CROSSLAYS, 1.50" (2) 200' OF 2.00" D.J. Poly CROSSLAYS, 2.50" (1) 200' OF 3.00" D.J. Poly	SPEEDLAYS Speedlays Not Required GENERATOR Harrison 6kW MAS-D Hydraulic
NOTE DIMENSIONS SHOWN ARE APPROXIMATE AND ARE SUBJECT TO MINOR DEVIATIONS AS MAY OCCUR OR BE NECESSARY IN CONSTRUCTION. MINOR DETAILS NOT SHOWN.						
1. SHORELINE RECEPTACLE WITH KUSSMAUL SUPER AUTO-EJECT LOCATED ON DRIVER SIDE OF THE CAB 2. AIR INLET WITH DISCONNECT COUPLING IN THE DRIVER SIDE STEPWELL 3. AIR OUTLET WITH SHUT OFF VALVE LOCATED ON THE DRIVER SIDE PUMP PANEL 4. BATTERY CHARGER LOCATED LOCATED BEHIND DRIVER'S SEAT 5. BATTERY CHARGE INDICATOR LOCATED ON THE DRIVER SIDE OF THE CAB 6. DUAL L.E.D. LIGHT STRIPS LOCATED IN HOSE BED PER SHOP ORDER 7. BRUSHED STAINLESS STEEL SCOFFLATE INSIDE EACH BODY COMPARTMENT DOOR 8. NINE ADJUSTABLE SHELVES IN COMPARTMENTS PER SHOP ORDER 9. ONE FLOOR MOUNTED SLIDE-OUT TRAY IN COMPARTMENT PER SHOP ORDER 10. TWO ALUMINUM PEGBOARD WITH TRACKS ON BACK WALL OF COMPARTMENTS PER SHOP ORDER 11. TWO ALUMINUM PEGBOARD WITH TRACKS ON THE SIDE WALL OF COMPARTMENT PER SHOP ORDER 12. CIRCUIT BREAKER PANEL IN COMPARTMENT PER SHOP ORDER 13. THREE 120V DUPLEX RECEPTACLES LOCATED IN CAB PER SHOP ORDER 14. TWO 120V 5-PLACE RECEPTACLE STRIPS IN COMPARTMENT PER SHOP ORDER 15. ONE 120V DUPLEX RECEPTACLE LOCATED IN COMPARTMENT PER SHOP ORDER 16. NON-RAISED AERIAL PEDESTAL 17. 1500 GPM HIGH FLOW WATERWAY 18. 120V POWER TO AERIAL TIP 19. LIMITED RETRACTION NOT REQUIRED						

		JOB NO.	34700
		SCALE	DATE
TITLE	107' ASCENDANT AERIAL LADDER AND BODY ASSEMBLY	DRAWN BY	TKA
FOR	RALPHO FIRE COMPANY NO. 1 SHAMOKIN, PENNSYLVANIA	CHECKED BY	CRI
DWG NO.	34700AD	SHEET SIZE	SHEET NO.
REV	DATE	BY	CH