

- HOSEBED CAPACITIES
- ① 200' OF 2.50" D.J. POLY HOSE
 - ② 450' OF 2.50" D.J. POLY HOSE
 - ③ 1000' OF 4.00" RUBBER LDH HOSE
 - ④ 700' OF 2.50" D.J. POLY HOSE

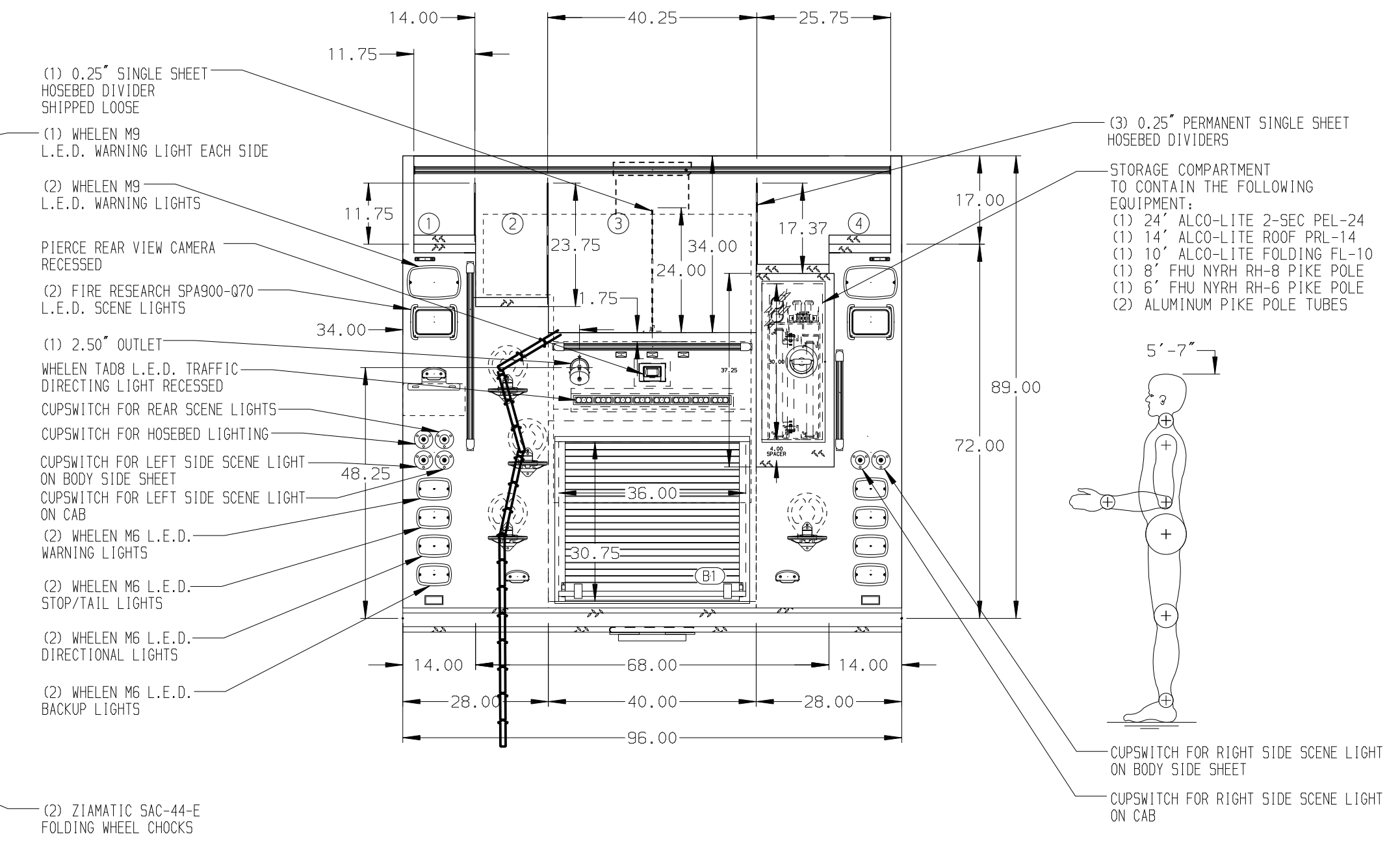
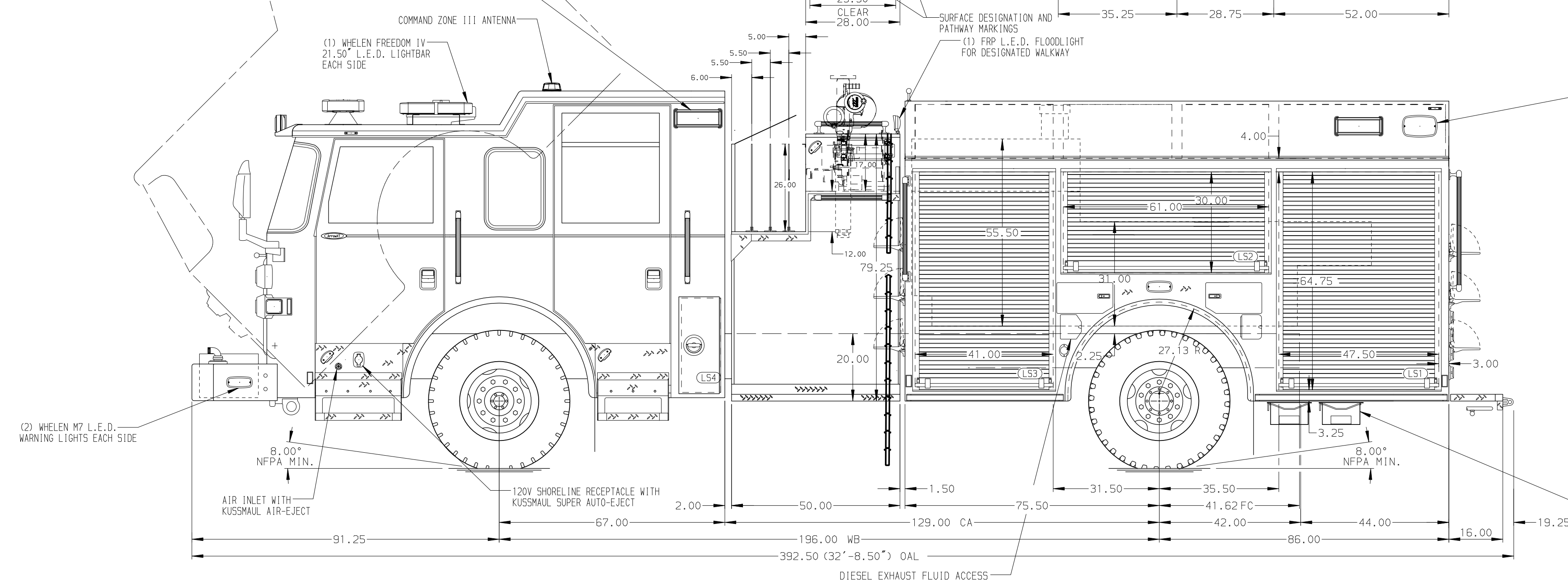

ALUMINUM BODY

MAXIMUM O.A.H. 120.00"

SIDE ROLL AND FRONTAL IMPACT PROTECTION

NOTE
DIMENSIONS SHOWN ARE APPROXIMATE AND ARE SUBJECT TO MINOR DEVIATIONS AS MAY OCCUR OR BE NECESSARY IN CONSTRUCTION. MINOR DETAILS NOT SHOWN.

1. SUPERZ TIRE CHAINS TO BE SHIPPED LOOSE
2. BATTERY CHARGER BEHIND THE DRIVER'S SEAT
3. BATTERY CHARGER INDICATOR LOCATED NEAR DRIVER'S SEAT RISER WITH BRACKET
4. DUAL L.E.D. LIGHT STRIPS LOCATED IN HOSE BED
5. DRIP PAN GUARD FOR ROLL-UP DOOR IN LS1, LS2, LS3, B1, RS1, RS2, AND RS3
6. FULL WIDTH/DEPTH ADJUSTABLE SHELVES TWO IN LS3 AND RS1 AND ONE IN LS1
7. ONE ADJUSTABLE SLIDE-OUT TRAY IN B1
8. ONE ADJUSTABLE TILTING SLIDE-OUT TRAY IN LS2
9. ONE FLOOR MOUNTED SLIDE-OUT TRAY IN LS3
10. TWO SLIDE-OUT TOOL DRAWERS WITH PEGBOARD PATTERN IN LS1

11. ALUMINUM 4-WAY ON FENDER PANELS
12. PAC TRAC ON THE REAR WALL OF RS2
13. CIRCUIT BREAKER PANEL IN RS3
14. HANNAY MODEL E1618-17-18 CORD REEL WITH 200' OF 12/3 CABLE IN LEFT SIDE OF THE CARGO AREA ABOVE THE PUMP
15. 120V NEMA DUPLEX RECEPTACLE IN LS1, LS3, RS1, AND RS3
16. 120V NEMA DUPLEX RECEPTACLE BEHIND THE DRIVER'S AND OFFICER'S SEAT, IN THE EMS CABINET, AND ON TOP OF THE ENGINE TUNNEL
17. ONSPOT AUTOMATIC TIRE CHAINS TO BE PROVIDED AT THE REAR
18. 2" RETAINING LIP IN RS3
19. VERTICAL PARTITION IN LS1

REV	DATE	BY	CH	ARROW	XT
25MAR20	LST	DTS			
26FEB20	LST	DTS			

		JOB NO.	34654		
		SCALE	DATE		
Pierce MANUFACTURING INC.	TITLE	1500-D-750P, 161" BODY LS RESCUE (12" CLEVELAND NOTCH) RS FH FRONT & REAR FDLER, (4) XLYS, DELUGE	DRAWN BY	LST	11DEC19
	FOR	TOWNSHIP OF NUTLEY NUTLEY, NEW JERSEY	CHECKED BY	CDU	12DEC19
	DWG NO.	34654AD	SHEET SIZE	D	SHEET NO. 1 OF 1