

- HOSEBED CAPACITIES
- ① 300' OF 3.00" D.J. HOSE
 - ② 1150' OF 5.00" D.J. HOSE
 - ③ 200' OF 2.50" D.J. HOSE

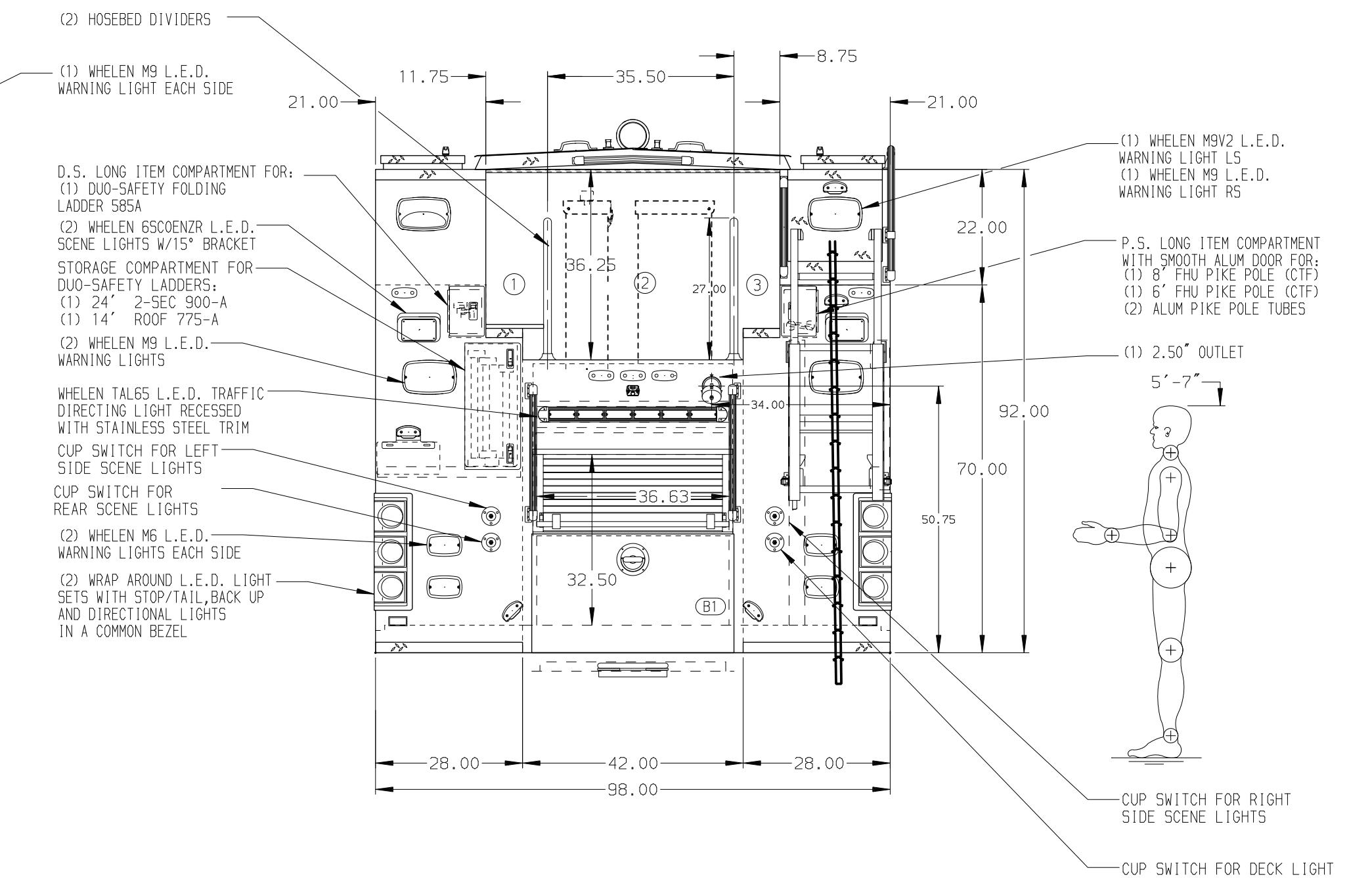
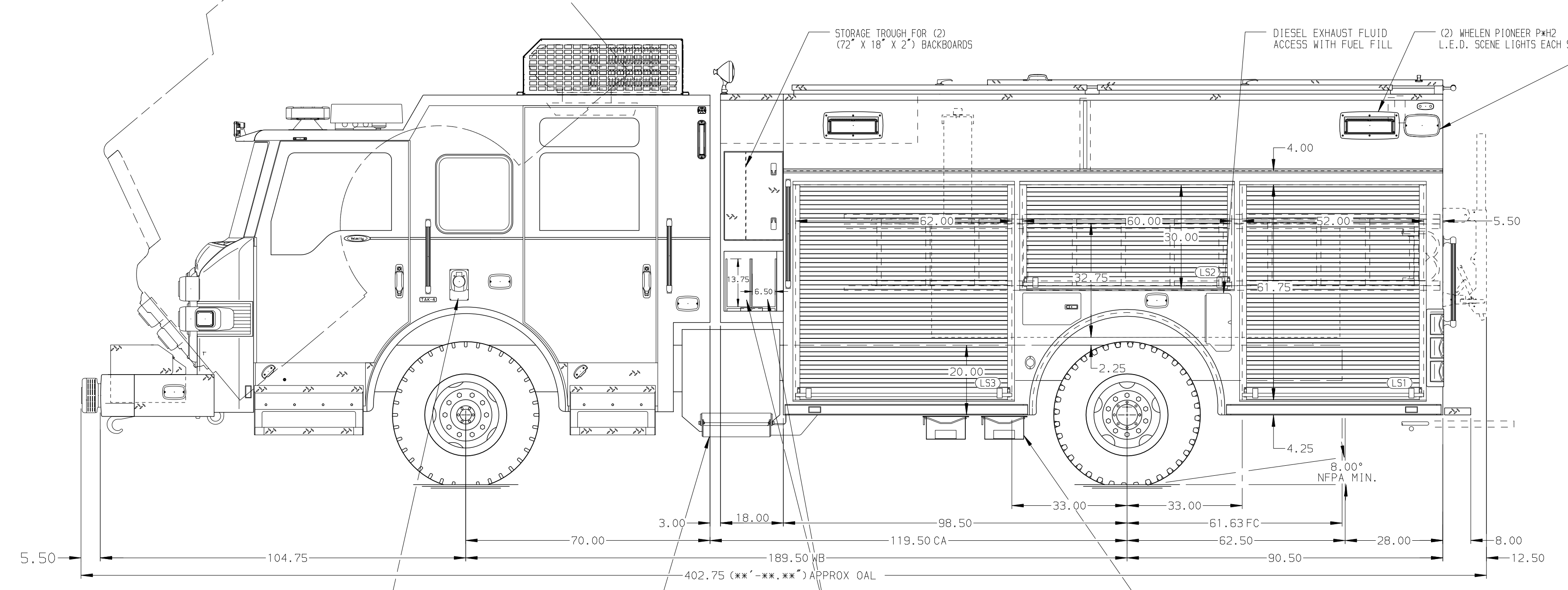

ALUMINUM BODY

FRONTAL IMPACT PROTECTION

NOTE
DIMENSIONS SHOWN ARE APPROXIMATE AND ARE SUBJECT TO MINOR DEVIATIONS AS MAY OCCUR OR BE NECESSARY IN CONSTRUCTION. MINOR DETAILS NOT SHOWN.

1. AIR INLET WITH DISCONNECT COUPLING ON THE DS PUMP PANEL
2. BATTERY CHARGER LOCATED IN PUMP PLUMBING AREA
3. BATTERY CHARGE INDICATOR LOCATED NEAR DRIVER'S SEAT R15ER WITH BRACKET
4. SUB-FEED CIRCUIT BREAKER PANEL IN COMPARTMENT L53
5. ONE FULL WIDTH/DEPTH ADJUSTABLE SHELF IN COMPARTMENTS L51 AND B1; TWO IN L53, R51, AND R53
6. ONE ADJUSTABLE TILTING SLIDE-OUT TRAY IN COMPARTMENT R52
7. ONE SWING-OUT ALUMINUM TOOL BOARD IN COMPARTMENT L51
8. ONE FLOOR MOUNTED SLIDE-OUT TRAY IN COMPARTMENTS L51 AND R53
9. ONE ADJUSTABLE HEIGHT SLIDE-OUT TRAY IN COMPARTMENT R53
10. 120V DUPLEX RECEPTACLE LOCATED IN THE EMS COMPARTMENT AND COMPARTMENTS L51 AND R51

11. VOGEL LUBE SYSTEM IN COMPARTMENT L53

REV	DATE	BY	CH	VELOCITY
23MAR20		KLE	PPE	MAKE
02MAR20		KLE	PPE	PIERCE
26NOV19		KLE	NPE	MODEL

TITLE	1500-D-530P, 500G WATER W/30 G FOAM, 189" FHFD BODY LADDERS THRU BODY, (2) XLYAS, DELUGE, (2) HSH
FOR	PINELLAS PARK PINELLAS PARK, FLORIDA
DWG NO.	34559AD

JOB NO.	34559
SCALE	1:24
DATE	
DRAWN BY	KLE
CHECKED BY	NPE
SHEET SIZE	D
SHEET NO.	1 OF 1