

HOSEBED CAPACITIES  
 (1) 500' OF 2.50" D.J. POLYESTER HOSE

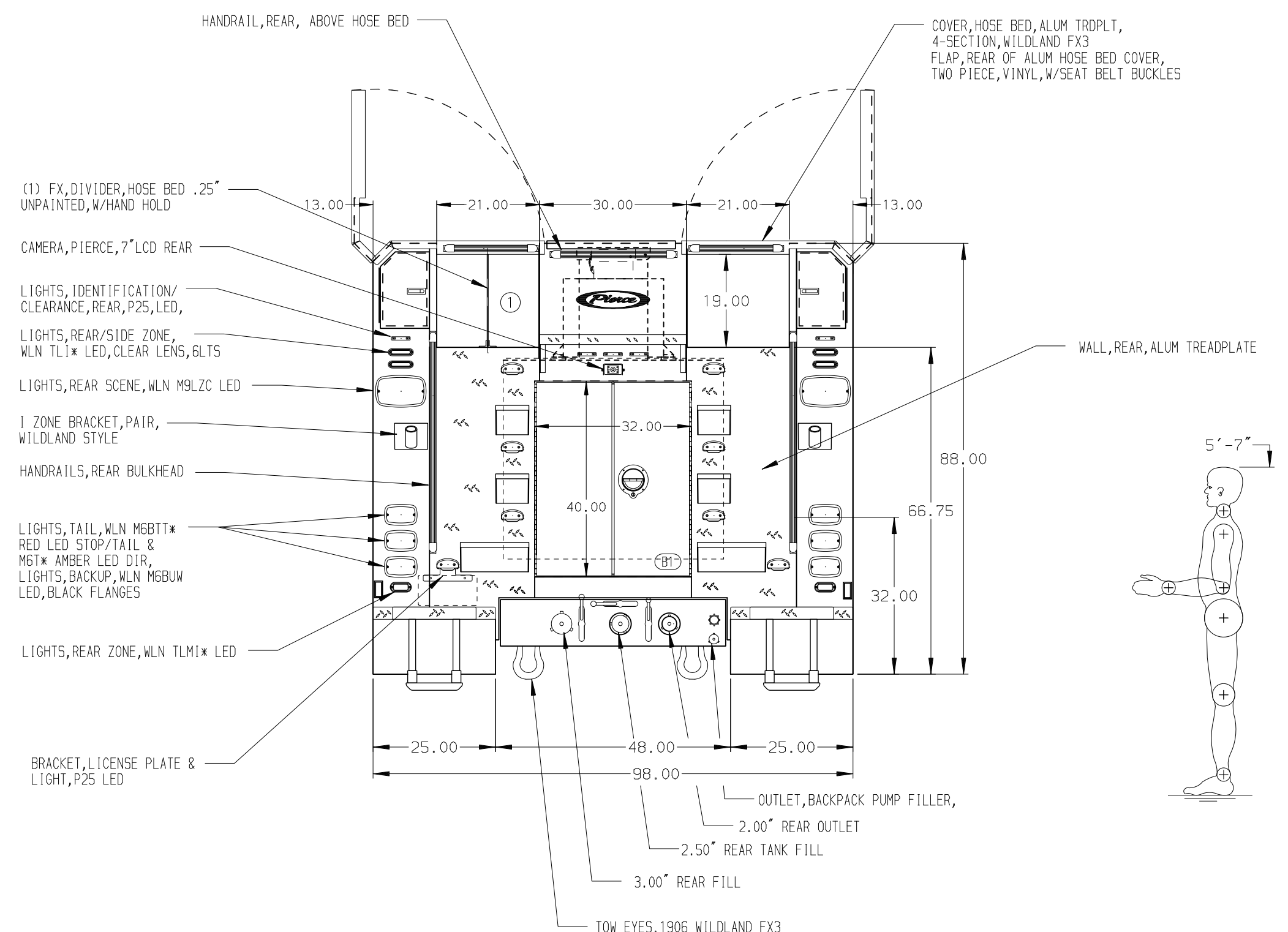
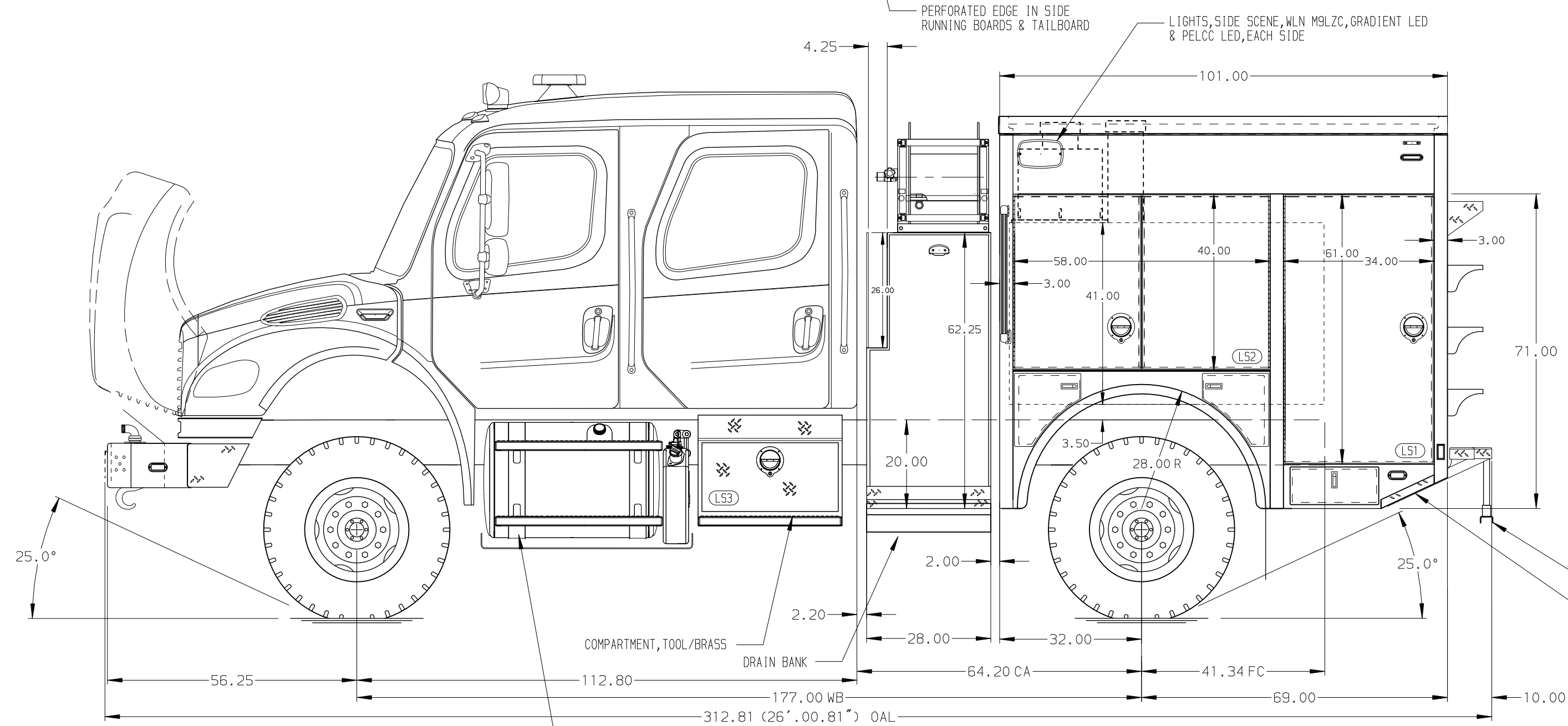

FUEL TANK, 70 GAL, ALUM  
 DEF TANK, LEFT SIDE, COMM  
 SKID PLATE & BRUSH GUARD FOR  
 FUEL & DEF TANKS, S/S, COMM CHASSIS

STAINLESS STEEL BODY

NOTE  
 DIMENSIONS SHOWN ARE APPROXIMATE  
 AND ARE SUBJECT TO MINOR DEVIATIONS  
 AS MAY OCCUR OR BE NECESSARY IN  
 CONSTRUCTION.  
 MINOR DETAILS NOT SHOWN.

						JOB NO.	34394
				MANUFACTURING INC. BRADENTON, FLORIDA		SCALE	DATE
				TITLE 500-D-500 WATER / 20 FOAM TANK, WILDLAND FX3 28" SIDE CONTROL, (1) DEADLAY		DRAWN BY	18FEB20
				MAKE FL FOR SAFFORD FIELD OFFICE SAFFORD, ARIZONA		CHECKED BY	18FEB20
				MODEL 4X4 M2-106		DWG NO.	34394AD
REV	DATE	BY	CH			SHEET SIZE	SHEET NO.
						D	1 OF 1