

HOSEBED CAPACITIES
 (1) 1200' OF 3.00" D.J. POLYESTER HOSE

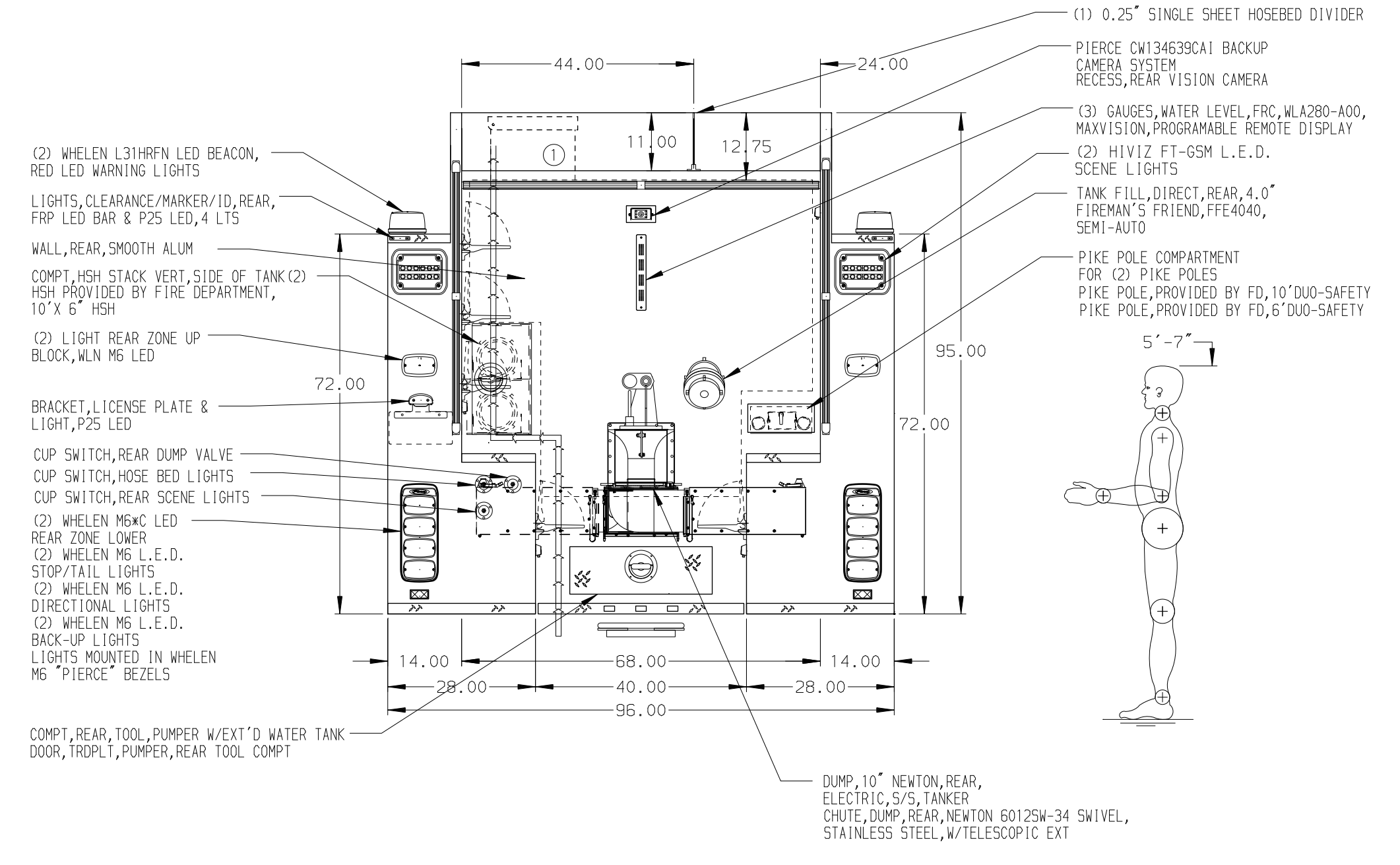
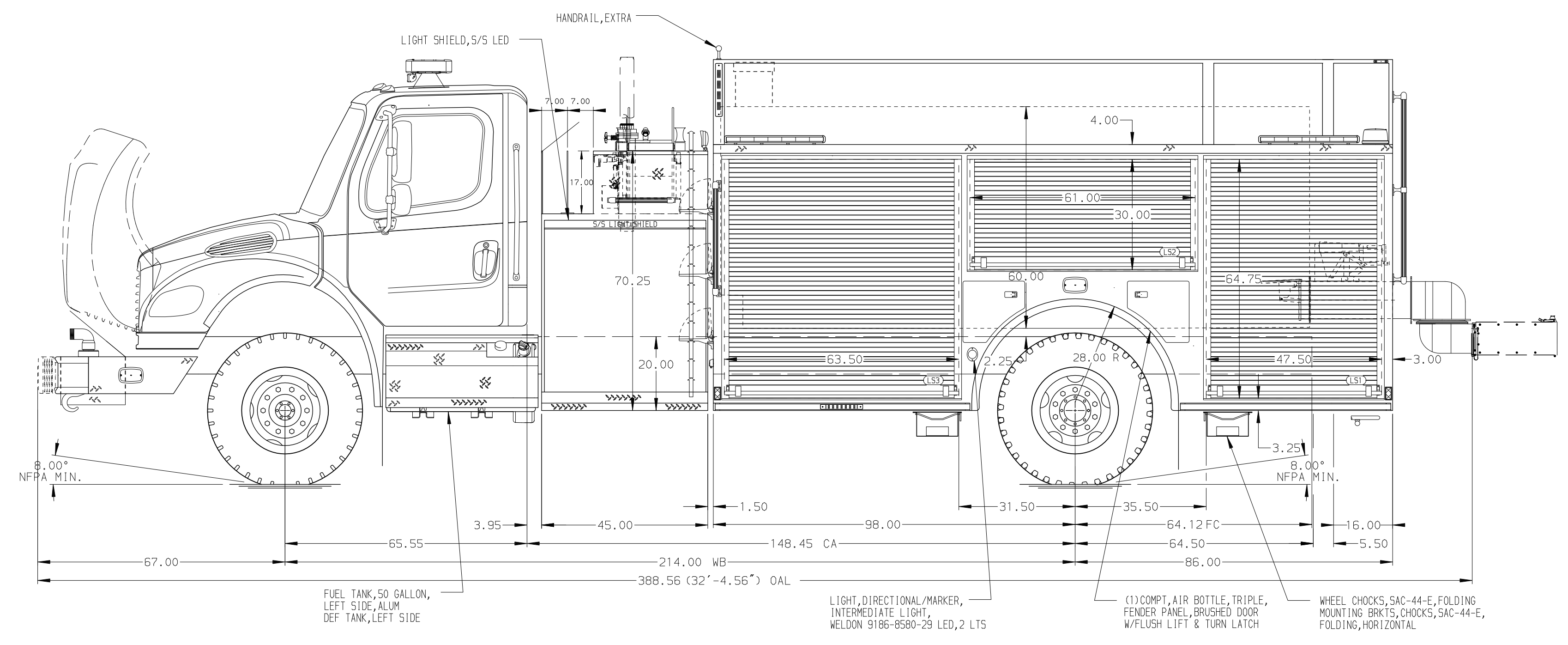

ALUMINUM BODY

NOTE
 DIMENSIONS SHOWN ARE APPROXIMATE AND ARE SUBJECT TO MINOR DEVIATIONS AS MAY OCCUR OR BE NECESSARY IN CONSTRUCTION. MINOR DETAILS NOT SHOWN.

REV.	DATE	BY	CHK'D	MODEL
03FEB20	CRH	DDR		CHASSIS DATA
17JAN20	RHU	DDR		CHASSIS FL
21OCT19	JLA	RW1		MODEL M2-106

<p>MANUFACTURING INC. BRADENTON, FLORIDA</p>		JOB NO.	34155
		DATE	SCALE 1:24
TITLE	1250-D-1950 POLY, 184" BODY, DS & PS FULL HEIGHT 45" SIDE CONTROL, (2) CROSSLAYS	11SEP19	DRAWN BY JLA
FOR	ST. STEPHENS VFD ST. STEPHENS, SOUTH CAROLINA	13SEP19	CHK'D BY RWI
DRWG. NO.	34155AD	SHEET NO. 1 OF 1	SHEET SIZE D