

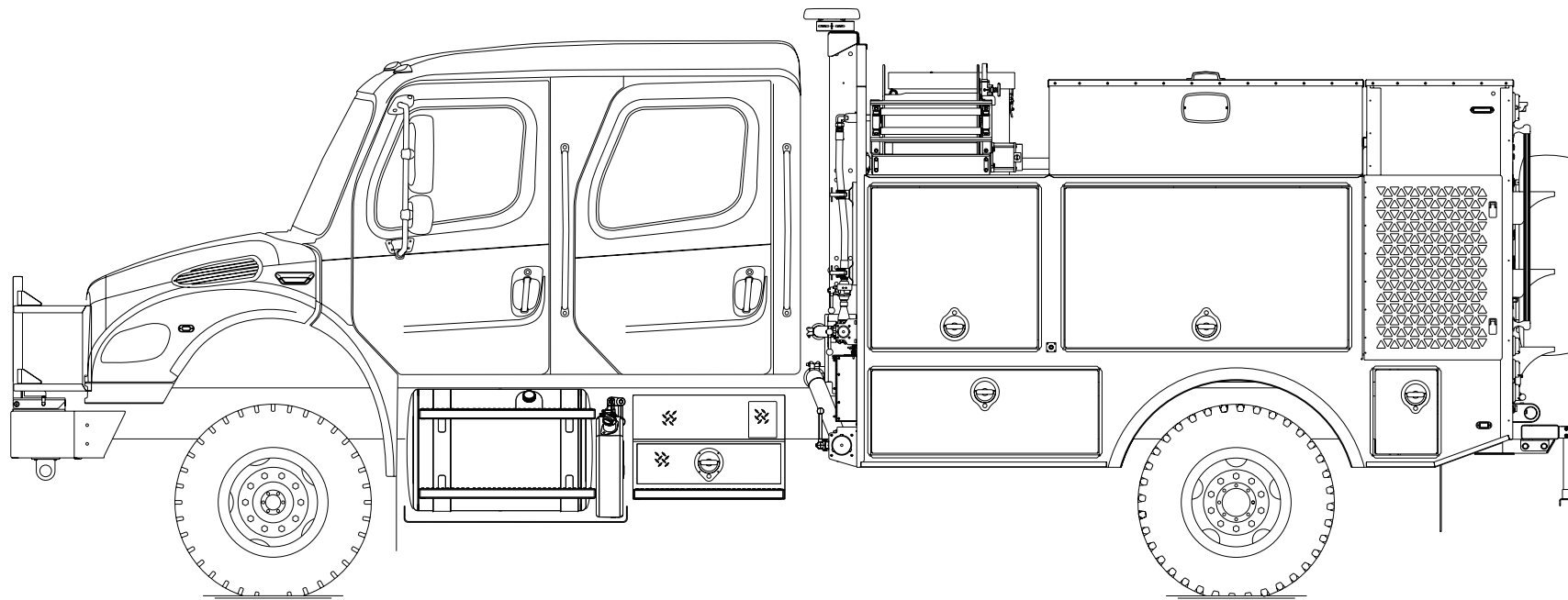

PERFORM. LIKE NO OTHER.™

Bureau of Land Management Freightliner Heavy Wildland Engine



Chassis

Chassis	Freightliner M2-106 cab
Seating Capacity	5
Overall Height	10' 10"
Overall Length	27' 10"
GVW Rating	40,000 lb
Safety	Side Roll Protection In-Cab Roll Over Protection System
Front Axle	Freightliner, 14,000 lb
Rear Axle	Meritor RS, 26,000 lb
Engine	Cummins L9, 350 hp

Body

Material	Stainless steel
Shelving	Adjustable, up to 500 lb
Doors	Lap
Pump	Darley HSE 65k Kubota, 300 gpm @ 150 psi
Tank	800 gallons
Pump Panel	Rear-mount pump panel
Foam System	Waterous Aquis 1.5
Foam Cell	20 gallons

Pierce Manufacturing, an Oshkosh Corporation Company
2600 American Drive, Appleton, WI 54914

Contact your local Pierce dealer for more information

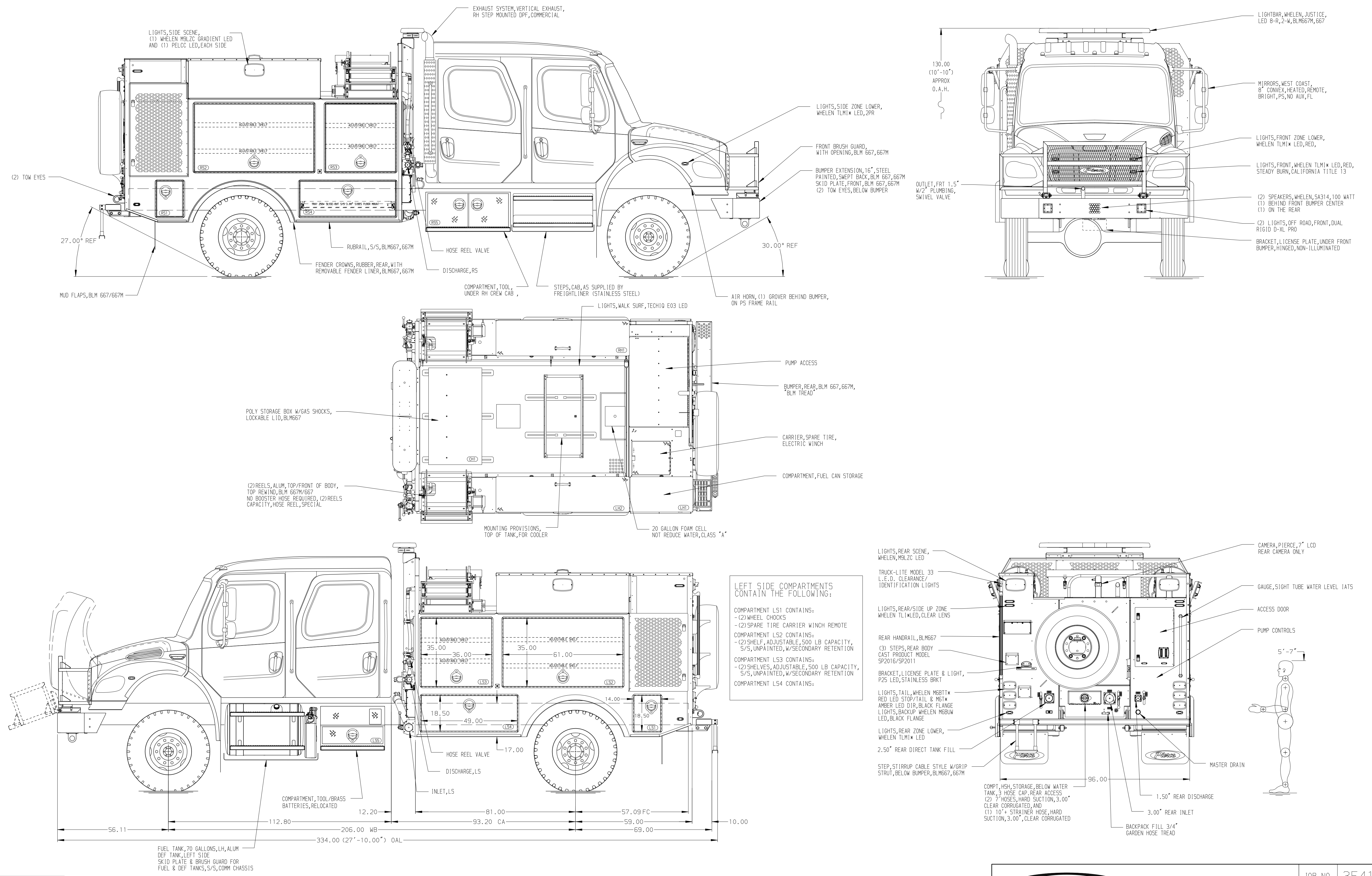

NOTE
 DIMENSIONS SHOWN ARE APPROXIMATE AND ARE SUBJECT TO MINOR DEVIATIONS AS MAY OCCUR OR BE NECESSARY IN CONSTRUCTION. MINOR DETAILS NOT SHOWN.

(800 GALLON WATER TANK 3598594)

NOTE: WINTERIZE BEFORE SHIPMENT, BLM667/667M

CHASSIS DATA	TITLE	800 GAL WATER W/20 FOAM, DARLEY, HSE 65K W/KUBOTA V2403T
MAKE	FOR	(2) BOOSTER REELS, FOAM SYSTEM
FL		BLM BATTLE MOUNTAIN
MODEL		BOISE, IDAHO
M2-106	DWG NO.	35413AD
4x4		

	JOB NO.	35413
	SCALE	DATE
	1:24	
	DRAWN BY	JLA
	CHECKED BY	RWI
	SHEET SIZE	D
	SHEET NO.	1 OF 1